

The TAMA logo, featuring the brand name in a bold, sans-serif font with a registered trademark symbol, set against a dark rectangular background.

**DRUMS AND HARDWARE**  
2017 GENERAL CATALOG

TAMA DRUMS 2017 GENERAL CATALOG

The TAMA logo, featuring the brand name in a bold, sans-serif font with a registered trademark symbol, set against a dark rectangular background.

 Tama Drums  TAMAofficial  officialtamadrums  @TAMAofficial

www.tama.com  
The contents of this catalog are copyrighted 2017 by Hoshino Gakki and not to be copied in any manner without the written permission of HOSHINO GAKKI CO., LTD.  
©2017 OCT161074 Printed in Japan (E)



# TABLE OF CONTENTS

8-13	STAR Drums
20-33	Starclassic
34-37	Superstar Hyper-Drive Maple
38-41	Silverstar
42-43	Imperialstar
44	Rhythm Mate
46-49	Snare Drums
52-53	Drum Pedals
54	Hi-Hat Stands
55	Drum Thrones
56	Snare Stands
57-58	Cymbal Stands
58-59	Tom Stands & Tom Holders
60	Hardware Kits
61	Power Tower System
62-63	Clamps & Attachments
64-65	Microphone Stands & Accessories
66	TAMA Percussion
67	Practice Tools
68-69	Bags
70-77	Accessories
78-79	Sticks







RTAMA1

STAR MAPLE Finish: Gloss Sycamore - MGSM





STAR WALNUT Finish: Grand Aqua Blue - GAQ



**TAMA**®

HEAD MADE BY REMO U.S.A.



# TAMA STAR BUBINGA

MADE IN JAPAN

STAR is the flagship line for TAMA drums. It takes the knowledge and research we cultivated for the Starclassic series to the next level, by reexamining every detail to enhance shell resonance.

STAR Bubinga features a much thinner shell than Starclassic Bubinga. In addition, every shell comes equipped with 9mm thick Sound Focus Rings for structural support. This shell configuration provides clear projection and resonance to highlight the distinct sound of Bubinga.



**COLOR** Natural Indian Laurel -LNTI

**DRUMS**

- 18"x22" bass drum
- 7"x10" tom tom
- 8"x12" tom tom
- 14"x14" floor tom
- 16"x16" floor tom
- 6.5"x14" snare drum

**COLOR** Dark Red Cordia -CDKR

**DRUMS**

- 14"x18" bass drum
- 8"x12" tom tom
- 14"x14" floor tom
- 5.5"x14" snare drum



## BASIC MODEL NUMBERS

Bass Drums		
Diameter	Depth	Model No.
18"	14"	TBB1814S
	15"	TBB1815S
	16"	TBB1816S
20"	14"	TBB2014S
	16"	TBB2016S
	17"	TBB2017S
	18"	TBB2018S
22"	14"	TBB2214S
	16"	TBB2216S
	17"	TBB2217S
	18"	TBB2218S
24"	14"	TBB2414S
	16"	TBB2416S
	17"	TBB2417S
26"	14"	TBB2614S
	16"	TBB2616S

Floor Toms		
Diameter	Depth	Model No.
14"	12"	TBF1412S
	13"	TBF1413S
	14"	TBF1414S
15"	13"	TBF1513S
	14"	TBF1514S
	15"	TBF1515S
16"	14"	TBF1614S
	15"	TBF1615S
18"	14"	TBF1814S
	15"	TBF1815S
	16"	TBF1816S

Snare Drums		
Diameter	Depth	Model No.
13"	6"	TBS136S
	5.5"	TBS1455S
14"	6.5"	TBS1465S
	8"	TBS148S

Tom Toms		
Diameter	Depth	Model No.
8"	6"	TBT0806S
	7"	TBT0807S
	8"	TBT0808S
10"	6.5"	TBT1065S
	7"	TBT1007S
	8"	TBT1008S
	9"	TBT1009S
12"	10"	TBT1010S
	7"	TBT1207S
	8"	TBT1208S
	9"	TBT1209S
13"	10"	TBT1210S
	11"	TBT1211S
	7.5"	TBT1375S
	9"	TBT1309S
	10"	TBT1310S
14"	11"	TBT1311S
	12"	TBT1312S
	8"	TBT1408S
	10"	TBT1410S
	11"	TBT1411S
14"	12"	TBT1412S
	13"	TBT1413S

## SPECIFICATIONS

- Shells  
4.5mm, 5ply Bubinga + 1 inner ply Cordia (+ 1 additional outer ply Indian Laurel for LNTI), or 4ply Bubinga + 1 outer & 1 inner ply Cordia for CDKG/CDKR/CSTN, or 6ply Bubinga + 1 outer & 1 inner ply Bosse for ESEB/EWSB, w/ 9mm Sound Focus Rings
- STAR Bearing Edges
- Super Resonant Mounting System (US.PAT.NO.9024163)
- Quick-Lock Tom Brackets (US.PAT.NO.9269337)
- STAR Floor Tom Legs
- STAR Bass Drum Spurs (US.PAT.NO.9093051)
- Minimum Shell Contact
- Die-Cast Hoops
- Hold Tight Washers (US.PAT.NO.7307204)
- Remo® Drum Heads

## MODEL NUMBER SYSTEM - Individual Drums

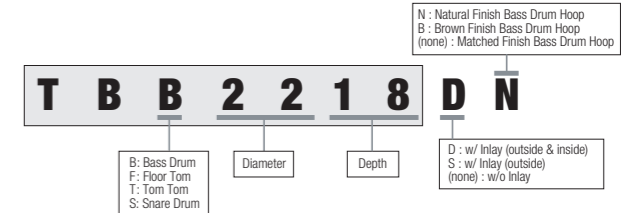

## WOOD INLAY OPTION

STAR drums come standard with a beautiful center wood inlay on the outside of the shells. We also offer the inlay on the inside of the Sound Focus Rings, or without any inlay at all. \*The "No Inlay" option is NOT available on the Natural Indian Laurel (LNTI) finish, Sierra Red Bosse Burst (ESEB), Wild Sea Blue Bosse (EWSB).

Ex Model No.: TBT1208S (Wood Inlay Outside), TBT1208D (Wood Inlay Outside & Inside), TBT1208 (Without Inlay)

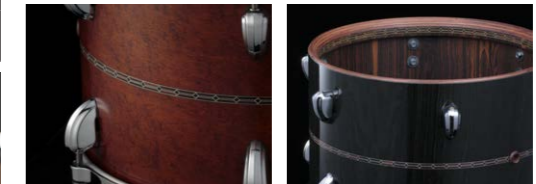

## BASS DRUM HOOP COLOR OPTION

Bass drums come standard with matching finish wood hoops. We also offer a Natural Matte Finish and a Dark Brown Matte Finish for the hoops, available for most drum colors.

Ex Model No.: TBB2214S (Matched Finish Hoops), TBB2214SB (Dark Brown Matte Finish Hoops), TBB2214SN (Natural Matte Finish Hoops)



## FINISHES (Lacquer)





# TAMA STAR MAPLE

MADE IN JAPAN

STAR is the flagship line for TAMA drums. It takes the knowledge and research we cultivated for the Starclassic series to the next level, by reexamining every detail to enhance shell resonance. STAR Maple shell's "Solid Core Ply" is a totally new design for this series. This unique shell provides the warm, open tone of Maple, combined with the rich, hearty sound of a solid ply shell.



**COLOR** Smoky Black -SKB

**DRUMS**

- 18"x22" bass drum
- 7"x10" tom tom
- 8"x12" tom tom
- 14"x14" floor tom
- 16"x16" floor tom
- 6.5"x14" snare drum



**COLOR** Gloss Sycamore -MGSM

**DRUMS**

- 14"x20" bass drum
- 8"x12" tom tom
- 14"x14" floor tom
- 5.5"x14" snare drum

**FINISHES (Lacquer)**

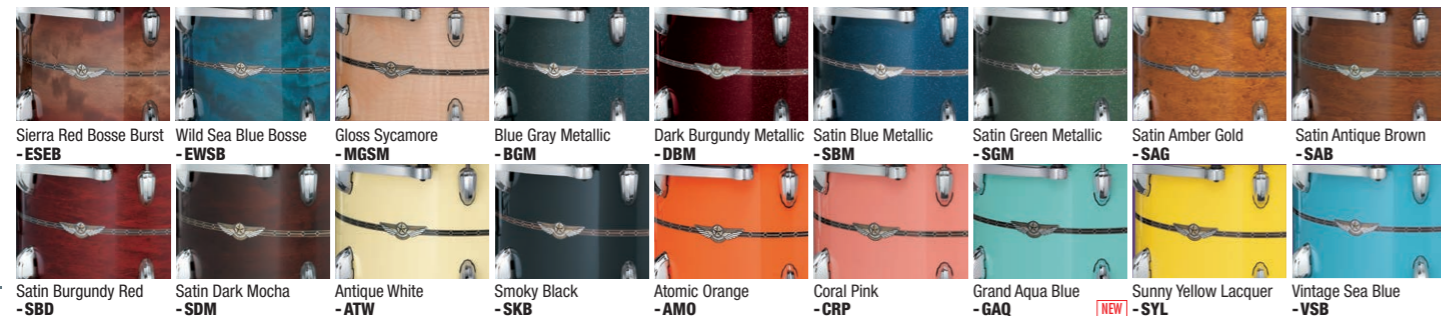

## BASIC MODEL NUMBERS

Bass Drums		
Diameter	Depth	Model No.
18"	14"	TMB1814S
	15"	TMB1815S
	16"	TMB1816S
20"	14"	TMB2014S
	16"	TMB2016S
	17"	TMB2017S
	18"	TMB2018S
22"	14"	TMB2214S
	16"	TMB2216S
	17"	TMB2217S
	18"	TMB2218S
24"	14"	TMB2414S
	16"	TMB2416S
	17"	TMB2417S
26"	14"	TMB2614S
	16"	TMB2616S

Floor Toms		
Diameter	Depth	Model No.
14"	12"	TMF1412S
	13"	TMF1413S
	14"	TMF1414S
15"	13"	TMF1513S
	14"	TMF1514S
	15"	TMF1515S
16"	14"	TMF1614S
	15"	TMF1615S
	16"	TMF1616S
18"	14"	TMF1814S
	15"	TMF1815S
	16"	TMF1816S

Snare Drums		
Diameter	Depth	Model No.
13"	6"	TMS136S
	5.5"	TMS1455S
14"	6.5"	TMS1465S
	8"	TMS148S

Tom Toms		
Diameter	Depth	Model No.
8"	6"	TMT0806S
	7"	TMT0807S
	8"	TMT0808S
10"	6.5"	TMT1065S
	7"	TMT1007S
	8"	TMT1008S
	9"	TMT1009S
	10"	TMT1010S
12"	7"	TMT1207S
	8"	TMT1208S
	9"	TMT1209S
13"	10"	TMT1310S
	11"	TMT1311S
	12"	TMT1312S
	13"	TMT1313S
14"	8"	TMT1408S
	10"	TMT1410S
	11"	TMT1411S
	12"	TMT1412S
	13"	TMT1413S

## SPECIFICATIONS

- Shells  
5mm, 5ply Maple (+1 additional outer ply Sycamore for MGSM, or 1 additional outer ply Bosse for ESEB/EWSB) w/ 5mm Sound Focus Rings
- STAR Bearing Edges
- Super Resonant Mounting System
- Quick-Lock Tom Brackets
- STAR Floor Tom Legs
- STAR Bass Drum Spurs
- Minimum Shell Contact
- Die-Cast Hoops
- Hold Tight Washers
- Remo® Drum Heads

## MODEL NUMBER SYSTEM - Individual Drums

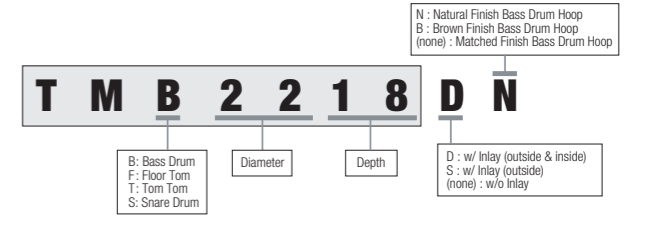

## WOOD INLAY OPTION

STAR drums come standard with a beautiful center wood inlay on the outside of the shells. We also offer the inlay on the inside of the Sound Focus Rings, or without any inlay at all. \*The "No Inlay" option is NOT available on the Gloss Sycamore (MGSM) finish, Sierra Red Bosse Burst (ESEB), Wild Sea Blue Bosse (EWSB).

Ex Model No.:  
TMT1208S (Wood Inlay Outside), TMT1208D (Wood Inlay Outside & Inside), TMT1208 (Without Inlay)

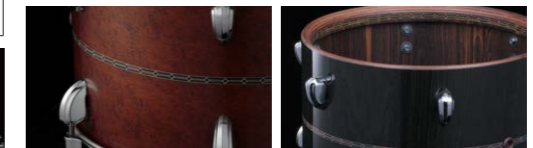

## BASS DRUM HOOP COLOR OPTION

Bass drums come standard with matching finish wood hoops. We also offer a Natural Matte Finish and a Dark Brown Matte Finish for the hoops, available for most drum colors. \*Natural Matte Finish hoops are NOT available for the Gloss Sycamore (MGSM) finish. \*Dark Brown Matte Finish hoops are NOT available for the Satin Dark Mocha (SDM) finish.

Ex Model No.:  
TMB2214S (Matched Finish Hoops), TMB2214SB (Dark Brown Matte Finish Hoops), TMB2214SN (Natural Matte Finish Hoops)





# TAMA STAR WALNUT

MADE IN JAPAN

STAR is the flagship line for TAMA drums. It takes the knowledge and research we cultivated for the Starclassic series to the next level, by reexamining every detail to enhance shell resonance. Walnut has long been favored by furniture makers for both its beauty and durability. As a drum shell material, Walnut's naturally EQ'ed tone has been praised by the drum community for both the stage and the studio. The STAR Walnut shells project booming low end with enough cut to be heard through any mix.



**COLOR** Satin Charcoal Japanese Sen -ASCS

### TW42RZS basic kit

including:  
 16"x22" bass drum  
 7"x10" tom tom  
 8"x12" tom tom  
 16"x16" floor tom

[add-on]  
 6.5"x14" snare drum



**COLOR** Grand Aqua Blue -GAQ

### DRUMS

16"x22" bass drum  
 9"x13" tom tom  
 16"x16" floor tom  
 6.5"x14" snare drum

## FINISHES (Lacquer)



## INDIVIDUAL MODEL NUMBERS

Bass Drums		
Diameter	Depth	Model No.
18"	14"	TWB1814
	15"	TWB1815
	16"	TWB1816
20"	14"	TWB2014
	16"	TWB2016
	17"	TWB2017
	18"	TWB2018
22"	14"	TWB2214
	16"	TWB2216
	17"	TWB2217
	18"	TWB2218
24"	14"	TWB2414
	16"	TWB2416
	17"	TWB2417
26"	14"	TWB2614
	16"	TWB2616

Floor Toms		
Diameter	Depth	Model No.
14"	12"	TWF1412
	13"	TWF1413
	14"	TWF1414
15"	13"	TWF1513
	14"	TWF1514
	15"	TWF1515
16"	14"	TWF1614
	15"	TWF1615
	16"	TWF1616
18"	14"	TWF1814
	15"	TWF1815
	16"	TWF1816

Snare Drums		
Diameter	Depth	Model No.
13"	6"	TWS136
14"	5.5"	TWS1455
	6.5"	TWS1465
	8"	TWS148

Tom Toms		
Diameter	Depth	Model No.
8"	6"	TWT0806
	7"	TWT0807
	8"	TWT0808
10"	6.5"	TWT1065
	7"	TWT1007
	8"	TWT1008
	9"	TWT1009
	10"	TWT1010
12"	7"	TWT1207
	8"	TWT1208
	9"	TWT1209
	10"	TWT1210
	11"	TWT1211
13"	7.5"	TWT1375
	9"	TWT1309
	10"	TWT1310
	11"	TWT1311
	12"	TWT1312
14"	8"	TWT1408
	10"	TWT1410
	11"	TWT1411
	12"	TWT1412
	13"	TWT1413

## SPECIFICATIONS

### Shells

All Walnut Shell TT/FT/SD: 6ply 5mm, BD: 7ply 6mm (except ASCS)  
 \*Satin Charcoal Japanese Sen (ASCS)  
 Walnut + 2 outer ply Japanese Sen TT/FT/SD: 6ply 5mm, BD: 7ply 6mm

- STAR Bearing Edges
- Super Resonant Mounting System
- Quick-Lock Tom Brackets
- STAR Floor Tom Legs
- STAR Bass Drum Spurs
- Minimum Shell Contact
- Die-Cast Hoops
- Hold Tight Washers
- Remo® Drum Heads

## MODEL NUMBER SYSTEM - Individual Drums

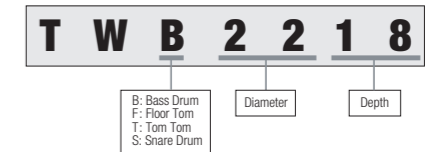

## KIT CONFIGURATION

TW42RZS 4pc Shell Kit w/ Chrome Hardware

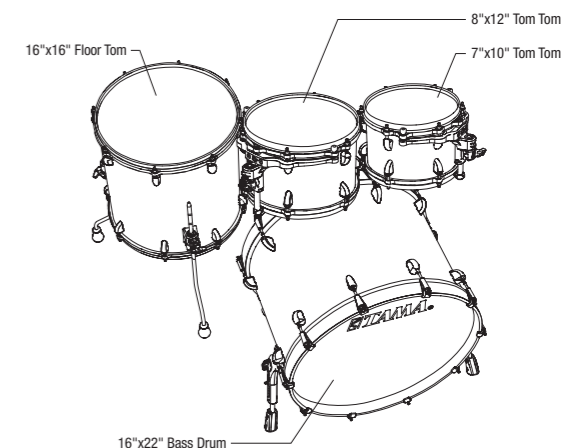

Notice: Shell kit does not include drum mounting hardware.







Past, Present, and Future



STARCLASSIC BUBINGA Finish: Satin Aztec Gold Metallic -SAM





Past, Present, and Future



STARCLASSIC MAPLE Finish: Jungle Quilted Bubinga Burst - QJB





Past, Present, and Future



STARCLASSIC PERFORMER B/B Finish: Lacquer Ocean Blue Ripple -LOR



# STARCLASSIC BUBINGA

-Exotic Finishes

Our Starclassic Bubinga offerings now include an Exotic Finish line which feature extraordinarily beautiful exotic wood finishes, in addition to the regular lacquer finishes. Their shells are made slightly thicker than those in our Starclassic Maple series to provide a more aggressive attack, a fuller deep and dark tone, and more powerful resonance.

Numerous options are available to meet the varied and critical needs of professional drummers including a selection of more than 30 different shell sizes. Starclassic Bubinga also features three shell hardware finishes to choose from: Black Nickel, Chrome and Smoked Black Nickel. Starclassic Bubinga is simply an unprecedented combination of sight and sound.



**COLOR** Crimson Tigerwood Fade -TCGF  
w/ smoked black nickel hardware

**BE52ZUS basic kit**

including:  
18"x22" bass drum  
8"x10" tom tom  
9"x12" tom tom  
12"x14" floor tom  
14"x16" floor tom

[add-on]  
6.5"x14" snare drum



**COLOR** Jungle Quilted Bubinga Burst -QJQB  
w/ smoked black nickel hardware

**BE42ZUS basic kit**

including:  
18"x22" bass drum  
8"x10" tom tom  
9"x12" tom tom  
14"x16" floor tom

[add-on]  
6.5"x14" snare drum

## KIT CONFIGURATIONS LIST

BE32RZS 3pc Shell Kit w/ Chrome Hardware  
BE32RZBS 3pc Shell Kit w/ Black Nickel Hardware  
BE32RZUS 3pc Shell Kit w/ Smoked Black Nickel Hardware

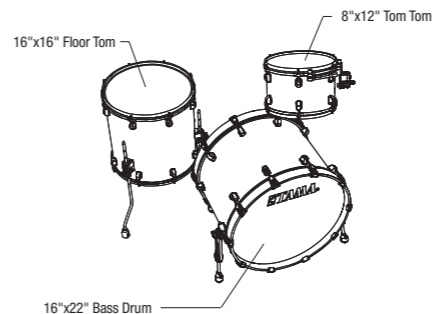

BE42ZS 4pc Shell Kit w/ Chrome Hardware  
BE42ZBS 4pc Shell Kit w/ Black Nickel Hardware  
BE42ZUS 4pc Shell Kit w/ Smoked Black Nickel Hardware

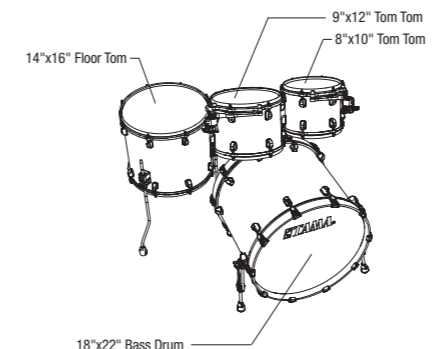

BE52ZS 5pc Shell Kit w/ Chrome Hardware  
BE52ZBS 5pc Shell Kit w/ Black Nickel Hardware  
BE52ZUS 5pc Shell Kit w/ Smoked Black Nickel Hardware

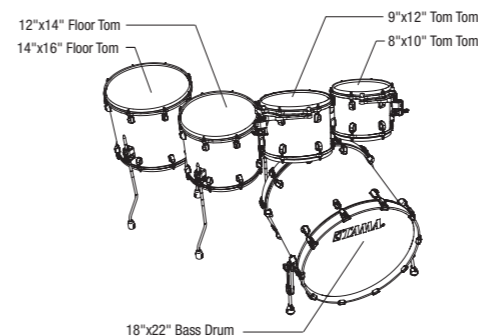

## INDIVIDUAL MODEL NUMBERS

Diameter	Depth	Model No.		
		Black Nickel	Chrome	Smoked Black Nickel
<b>Bass Drums</b>				
18"	14"	BEB1814M/ZB	BEB1814M/Z	BEB1814M/ZU
	16"	BEB1816M/ZB	BEB1816M/Z	BEB1816M/ZU
20"	14"	BEB2014M/ZB	BEB2014M/Z	BEB2014M/ZU
	16"	BEB2016M/ZB	BEB2016M/Z	BEB2016M/ZU
	18"	BEB2018M/ZB	BEB2018M/Z	BEB2018M/ZU
22"	14"	BEB2214M/ZB	BEB2214M/Z	BEB2214M/ZU
	16"	BEB2216M/ZB	BEB2216M/Z	BEB2216M/ZU
	18"	BEB2218M/ZB	BEB2218M/Z	BEB2218M/ZU
	20"	BEB2220M/ZB	BEB2220M/Z	BEB2220M/ZU
24"	14"	BEB2414M/ZB	BEB2414M/Z	BEB2414M/ZU
	16"	BEB2416M/ZB	BEB2416M/Z	BEB2416M/ZU
	18"	BEB2418M/ZB	BEB2418M/Z	BEB2418M/ZU
<b>Floor Toms</b>				
14"	12"	BEF1412B	BEF1412	BEF1412U
	14"	BEF1414B	BEF1414	BEF1414U
16"	14"	BEF1614B	BEF1614	BEF1614U
	16"	BEF1616B	BEF1616	BEF1616U
18"	16"	BEF1816B	BEF1816	BEF1816U
<b>Tom Toms</b>				
8"	6"	BET0806B	BET0806	BET0806U
	7"	BET0807B	BET0807	BET0807U
	8"	BET0808B	BET0808	BET0808U
10"	6.5"	BET1065B	BET1065	BET1065U
	7"	BET1007B	BET1007	BET1007U
	8"	BET1008B	BET1008	BET1008U
	9"	BET1009B	BET1009	BET1009U
12"	7"	BET1207B	BET1207	BET1207U
	8"	BET1208B	BET1208	BET1208U
	9"	BET1209B	BET1209	BET1209U
	10"	BET1210B	BET1210	BET1210U
13"	7.5"	BET1375B	BET1375	BET1375U
	9"	BET1309B	BET1309	BET1309U
	10"	BET1310B	BET1310	BET1310U
	11"	BET1311B	BET1311	BET1311U
14"	10"	BET1410B	BET1410	BET1410U
	11"	BET1411B	BET1411	BET1411U
	12"	BET1412B	BET1412	BET1412U
16"	13"	BET1613B	BET1613	BET1613U
	14"	BET1614B	BET1614	BET1614U
<b>Snare Drums</b>				
13"	6"	BES136B	BES136	BES136U
	5.5"	BES1455B	BES1455	BES1455U
	6.5"	BES1465B	BES1465	BES1465U
14"	6.5"	BES1465B	BES1465	BES1465U
	8"	BES148B	BES148	BES148U

## SPECIFICATIONS

- Shells  
8ply Bubinga + 1 outer ply (Tigerwood for TCGF/TMGF, or Quilted Bubinga for QGQB/QJQB)  
TT/FT: 6mm, BD/SD: 7mm
- Star-Cast Mounting System
- Quick-Lock Tom Bracket
- EVANS® Heads
- Die-Cast Hoops
- Hold Tight™ Washers
- Claw Hooks w/ Rubber Spacers
- Cushioned Floor Tom Legs

## OPTION



## FINISHES (Lacquer)

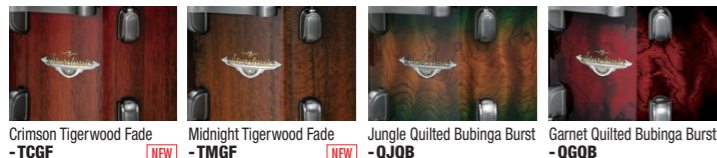

Crimson Tigerwood Fade -TCGF  
Midnight Tigerwood Fade -TMGF  
Jungle Quilted Bubinga Burst -QJQB  
Garnet Quilted Bubinga Burst -QGQB

## MODEL NUMBER SYSTEM - Individual Drums

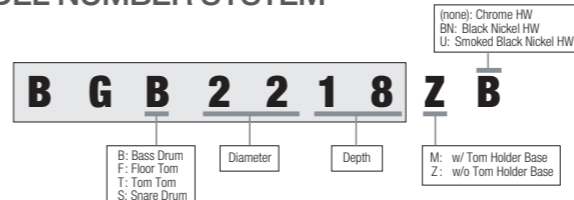

## MODEL NUMBER SYSTEM - Shell Kits

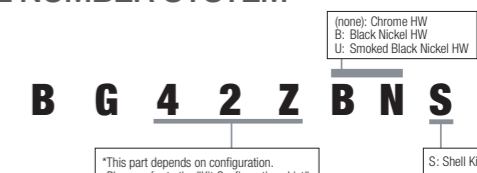





**COLOR** Satin Aztec Gold Metallic -SAM  
w/ smoked black nickel hardware

**BG52ZUS basic kit**

including:  
18"x22" bass drum  
8"x10" tom tom  
9"x12" tom tom  
12"x14" floor tom  
14"x16" floor tom

[add-on]  
6.5"x14" snare drum

## KIT CONFIGURATIONS LIST

**BG32RZS** 3pc Shell Kit w/ Chrome Hardware  
**BG32RZBNS** 3pc Shell Kit w/ Black Nickel Hardware  
**BG32RZUS** 3pc Shell Kit w/ Smoked Black Nickel Hardware

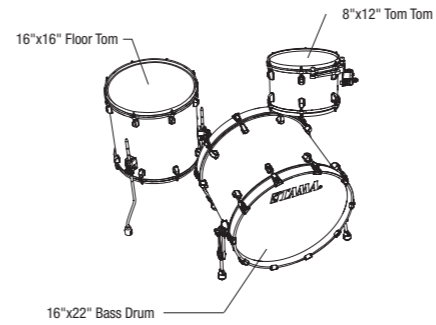

**BG42ZS** 4pc Shell Kit w/ Chrome Hardware  
**BG42ZBNS** 4pc Shell Kit w/ Black Nickel Hardware  
**BG42ZUS** 4pc Shell Kit w/ Smoked Black Nickel Hardware

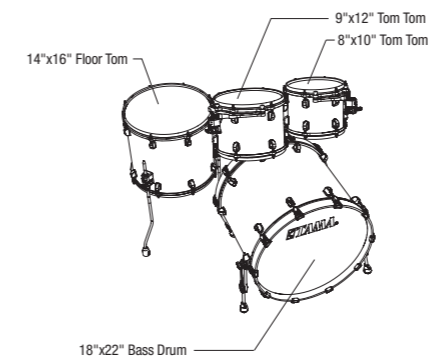

**BG52ZS** 5pc Shell Kit w/ Chrome Hardware  
**BG52ZBNS** 5pc Shell Kit w/ Black Nickel Hardware  
**BG52ZUS** 5pc Shell Kit w/ Smoked Black Nickel Hardware

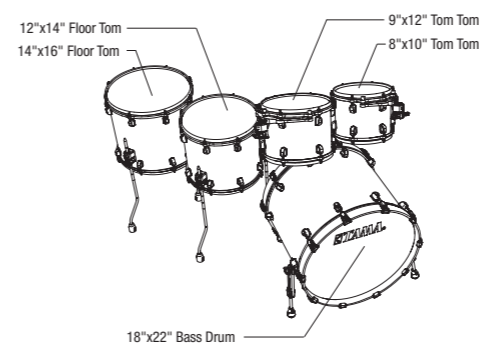

## INDIVIDUAL MODEL NUMBERS

Diameter	Depth	Model No.		
		Black Nickel	Chrome	Smoked Black Nickel
<b>Bass Drums</b>				
18"	14"	BGB1814M/ZBN	BGB1814M/Z	BGB1814M/ZU
	16"	BGB1816M/ZBN	BGB1816M/Z	BGB1816M/ZU
20"	14"	BGB2014M/ZBN	BGB2014M/Z	BGB2014M/ZU
	16"	BGB2016M/ZBN	BGB2016M/Z	BGB2016M/ZU
	18"	BGB2018M/ZBN	BGB2018M/Z	BGB2018M/ZU
22"	14"	BGB2214M/ZBN	BGB2214M/Z	BGB2214M/ZU
	16"	BGB2216M/ZBN	BGB2216M/Z	BGB2216M/ZU
	18"	BGB2218M/ZBN	BGB2218M/Z	BGB2218M/ZU
	20"	BGB2220M/ZBN	BGB2220M/Z	BGB2220M/ZU
24"	14"	BGB2414M/ZBN	BGB2414M/Z	BGB2414M/ZU
	16"	BGB2416M/ZBN	BGB2416M/Z	BGB2416M/ZU
	18"	BGB2418M/ZBN	BGB2418M/Z	BGB2418M/ZU
<b>Floor Toms</b>				
14"	12"	BGF1412BN	BGF1412	BGF1412U
	14"	BGF1414BN	BGF1414	BGF1414U
16"	14"	BGF1614BN	BGF1614	BGF1614U
	16"	BGF1616BN	BGF1616	BGF1616U
18"	16"	BGF1816BN	BGF1816	BGF1816U
	<b>Tom Toms</b>			
8"	6"	BGT0806BN	BGT0806	BGT0806U
	7"	BGT0807BN	BGT0807	BGT0807U
	8"	BGT0808BN	BGT0808	BGT0808U
10"	6.5"	BGT1065BN	BGT1065	BGT1065U
	7"	BGT1007BN	BGT1007	BGT1007U
	8"	BGT1008BN	BGT1008	BGT1008U
12"	9"	BGT1009BN	BGT1009	BGT1009U
	7"	BGT1207BN	BGT1207	BGT1207U
	8"	BGT1208BN	BGT1208	BGT1208U
13"	9"	BGT1209BN	BGT1209	BGT1209U
	10"	BGT1210BN	BGT1210	BGT1210U
	7.5"	BGT1375BN	BGT1375	BGT1375U
14"	9"	BGT1309BN	BGT1309	BGT1309U
	10"	BGT1310BN	BGT1310	BGT1310U
	11"	BGT1311BN	BGT1311	BGT1311U
16"	10"	BGT1410BN	BGT1410	BGT1410U
	11"	BGT1411BN	BGT1411	BGT1411U
	12"	BGT1412BN	BGT1412	BGT1412U
18"	13"	BGT1613BN	BGT1613	BGT1613U
	14"	BGT1614BN	BGT1614	BGT1614U
	<b>Snare Drums</b>			
13"	6"	BGS136BN	BGS136	BGS136U
	5.5"	BGS1455BN	BGS1455	BGS1455U
	6.5"	BGS1465BN	BGS1465	BGS1465U
14"	8"	BGS148BN	BGS148	BGS148U



**COLOR** Flat Black -FBK  
w/ smoked black nickel hardware

**BG42ZUS basic kit**

including:  
18"x22" bass drum  
8"x10" tom tom  
9"x12" tom tom  
14"x16" floor tom

[add-on]  
6.5"x14" snare drum

## SPECIFICATIONS

- Shells: 9ply Bubinga, TT/FT: 6mm, BD/SD: 7mm
- Star-Cast Mounting System
- Quick-Lock Tom Bracket
- EVANS® Heads
- Die-Cast Hoops
- Hold Tight™ Washers
- Claw Hooks w/ Rubber Spacers
- Cushioned Floor Tom Legs

## OPTION



## FINISHES (Lacquer)

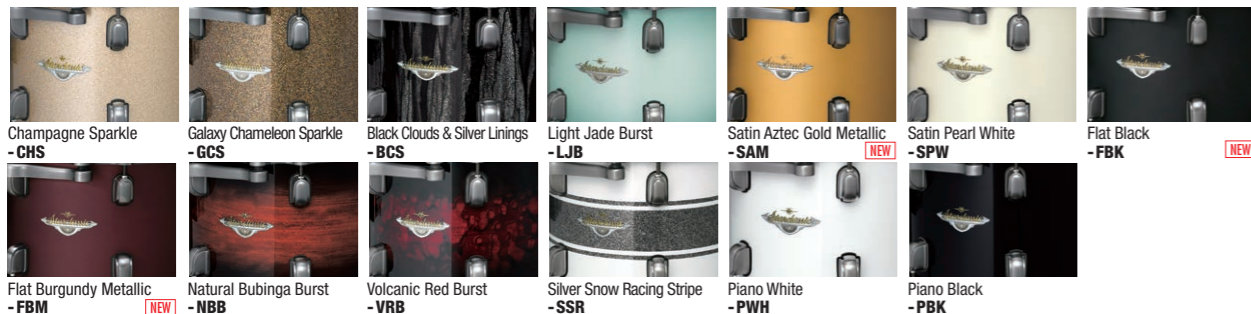

## MODEL NUMBER SYSTEM - Individual Drums

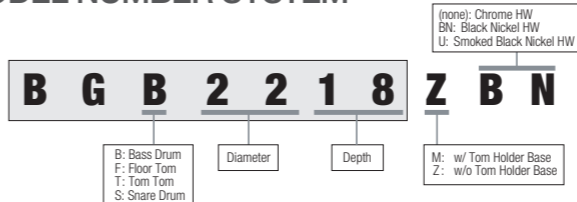

## MODEL NUMBER SYSTEM - Shell Kits

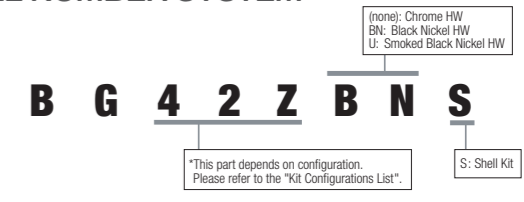



# STARCLASSIC MAPLE

-Exotic Finishes

In the '80s TAMA's Superstars and Imperialstars reigned supreme - the perfect drums for the times. But TAMA's builders and designers wanted something that transcended trends, something timeless - drums that understood a player's passion and allowed the expression of every genre, style, mood, and technique. They created Starclassic Maple drums...and ignited the thin-shell revolution. And now the new Exotic Finish line offers beautiful, one-of-a-kind exotic wood exteriors for that extra luxurious touch.



**COLOR** Emerald Pacific Walnut Burst -LEWB  
w/ smoked black nickel hardware

**ME42TZUS basic kit**

including:  
16"x22" bass drum  
7"x10" tom tom  
8"x12" tom tom  
16"x16" floor tom

[add-on]  
5.5"x14" snare drum



**COLOR** Figured Maple Gloss -GFMG  
w/ chrome hardware

**ME30CMS basic kit**

including:  
14"x20" bass drum  
8"x12" tom tom  
14"x14" floor tom  
MTH1000S single tom holder

[add-on]  
5.5"x14" snare drum

**FINISHES (Lacquer)**

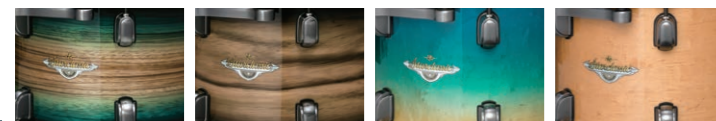

24

Emerald Pacific Walnut Burst -LEWB **NEW** Natural Pacific Walnut Burst -LNWB **NEW** Figured Caribbean Blue Fade -GFCB **NEW** Figured Maple Gloss -GFMG

## KIT CONFIGURATIONS LIST

ME42TZS 4pc Shell Kit w/ Chrome Hardware  
ME42TZBS 4pc Shell Kit w/ Black Nickel Hardware  
ME42TZUS 4pc Shell Kit w/ Smoked Black Nickel Hardware

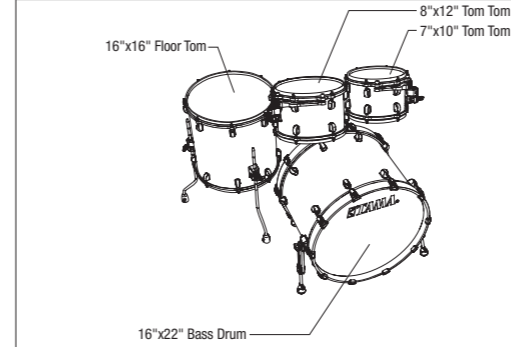

ME34CZS 3pc Shell Kit w/ Chrome Hardware  
ME34CZBS 3pc Shell Kit w/ Black Nickel Hardware  
ME34CZUS 3pc Shell Kit w/ Smoked Black Nickel Hardware

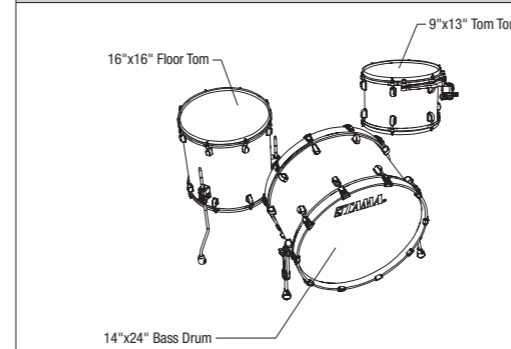

ME30CMS 3pc Shell Kit w/ Chrome Hardware  
ME30CMSB 3pc Shell Kit w/ Black Nickel Hardware  
ME30CMSU 3pc Shell Kit w/ Smoked Black Nickel Hardware

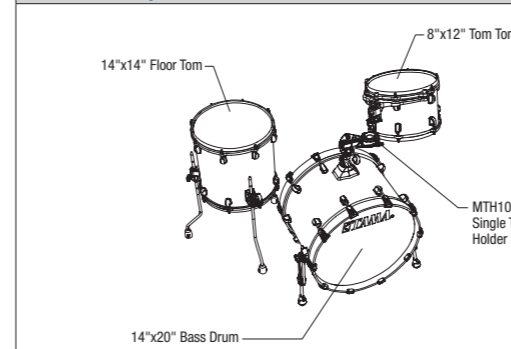

## SPECIFICATIONS

- Shells  
GFCB/GFMG TT/FT: 5ply Maple + 1 outer ply Figured Maple 5mm  
BD/SD: 7ply Maple + 1 outer ply Figured Maple 7mm  
LEWB/LNWB TT/FT: 6ply Maple + 1 outer ply Pacific Walnut 5mm  
BD/SD: 8ply Maple + 1 outer ply Pacific Walnut 7mm
- Star-Cast Mounting System
- Quick-Lock Tom Bracket
- EVANS® Heads
- Die-Cast Hoops
- Hold Tight™ Washers
- Claw Hooks w/ Rubber Spacers
- Cushioned Floor Tom Legs

## OPTION

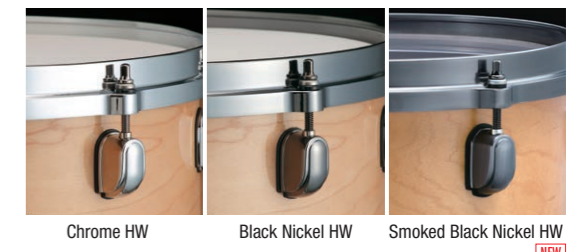

## MODEL NUMBER SYSTEM - Individual Drums

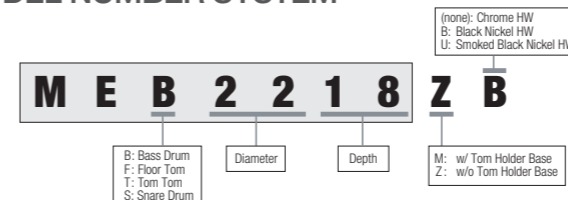

## MODEL NUMBER SYSTEM - Shell Kits

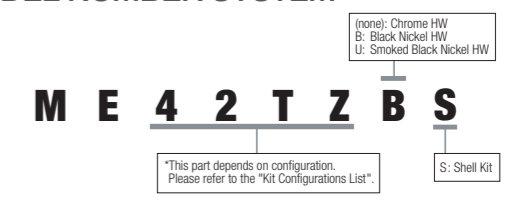

## INDIVIDUAL MODEL NUMBERS

Diameter	Depth	Model No.		
		Black Nickel	Chrome	Smoked Black Nickel
<b>Bass Drums</b>				
18"	14"	MEB1814M/ZB	MEB1814M/Z	MEB1814M/ZU
	16"	MEB1816M/ZB	MEB1816M/Z	MEB1816M/ZU
20"	14"	MEB2014M/ZB	MEB2014M/Z	MEB2014M/ZU
	16"	MEB2016M/ZB	MEB2016M/Z	MEB2016M/ZU
	18"	MEB2018M/ZB	MEB2018M/Z	MEB2018M/ZU
22"	14"	MEB2214M/ZB	MEB2214M/Z	MEB2214M/ZU
	16"	MEB2216M/ZB	MEB2216M/Z	MEB2216M/ZU
	18"	MEB2218M/ZB	MEB2218M/Z	MEB2218M/ZU
24"	14"	MEB2414M/ZB	MEB2414M/Z	MEB2414M/ZU
	16"	MEB2416M/ZB	MEB2416M/Z	MEB2416M/ZU
18"	18"	MEB2418M/ZB	MEB2418M/Z	MEB2418M/ZU
	<b>Floor Toms</b>			
14"	12"	MEF1412B	MEF1412	MEF1412U
	14"	MEF1414B	MEF1414	MEF1414U
16"	14"	MEF1614B	MEF1614	MEF1614U
	16"	MEF1616B	MEF1616	MEF1616U
18"	16"	MEF1816B	MEF1816	MEF1816U
	<b>Tom Toms</b>			
8"	6"	MET0806B	MET0806	MET0806U
	7"	MET0807B	MET0807	MET0807U
	8"	MET0808B	MET0808	MET0808U
10"	6.5"	MET1065B	MET1065	MET1065U
	7"	MET1007B	MET1007	MET1007U
	8"	MET1008B	MET1008	MET1008U
9"	9"	MET1009B	MET1009	MET1009U
	7"	MET1207B	MET1207	MET1207U
	8"	MET1208B	MET1208	MET1208U
12"	9"	MET1209B	MET1209	MET1209U
	10"	MET1210B	MET1210	MET1210U
	7.5"	MET1375B	MET1375	MET1375U
13"	9"	MET1309B	MET1309	MET1309U
	10"	MET1310B	MET1310	MET1310U
	11"	MET1311B	MET1311	MET1311U
14"	10"	MET1410B	MET1410	MET1410U
	11"	MET1411B	MET1411	MET1411U
16"	12"	MET1412B	MET1412	MET1412U
	13"	MET1613B	MET1613	MET1613U
	14"	MET1614B	MET1614	MET1614U
<b>Snare Drums</b>				
13"	6"	MES136B	MES136	MES136U
	5.5"	MES1455B	MES1455	MES1455U
	6.5"	MES1465B	MES1465	MES1465U
14"	8"	MES148B	MES148	MES148U

25





**COLOR** Flat Burgundy Metallic -FBM  
w/ smoked black nickel hardware

**MA42TZUS basic kit**

including:  
16"x22" bass drum  
7"x10" tom tom  
8"x12" tom tom  
16"x16" floor tom

[add-on]  
6.5"x14" snare drum.



**COLOR** Light Jade Burst -LJB  
w/ smoked black nickel hardware

**MA34CZUS basic kit**

including:  
14"x24" bass drum  
9"x13" tom tom  
16"x16" floor tom

[add-on]  
6.5"x14" snare drum.

**FINISHES (Lacquer)**



**KIT CONFIGURATIONS LIST**

**MA42TZS** 4pc Shell Kit w/ Chrome Hardware  
**MA42ZBNS** 4pc Shell Kit w/ Black Nickel Hardware  
**MA42TZUS** 4pc Shell Kit w/ Smoked Black Nickel Hardware

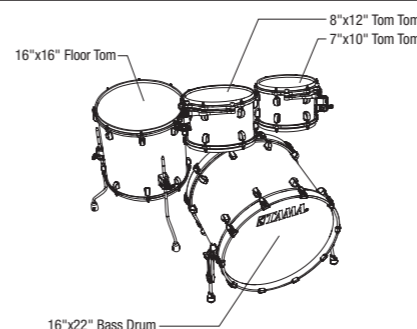

**MA34CZS** 3pc Shell Kit w/ Chrome Hardware  
**MA34CZBNS** 3pc Shell Kit w/ Black Nickel Hardware  
**MA34CZUS** 3pc Shell Kit w/ Smoked Black Nickel Hardware

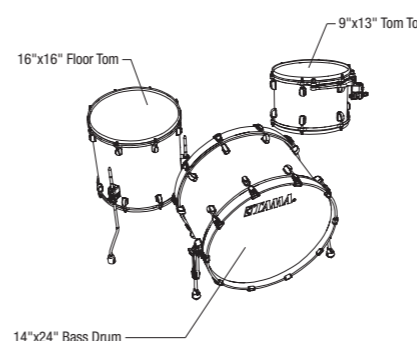

**MA30CMS** 3pc Shell Kit w/ Chrome Hardware  
**MA30CMBNS** 3pc Shell Kit w/ Black Nickel Hardware  
**MA30CMUS** 3pc Shell Kit w/ Smoked Black Nickel Hardware

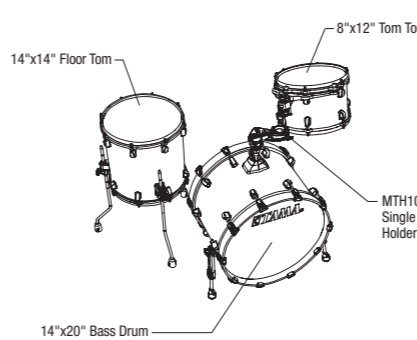

**INDIVIDUAL MODEL NUMBERS**

Diameter	Depth	Model No.		
		Black Nickel	Chrome	Smoked Black Nickel
<b>Bass Drums</b>				
18"	14"	MAB1814M/ZBN	MAB1814M/Z	MAB1814M/ZU
	16"	MAB1816M/ZBN	MAB1816M/Z	MAB1816M/ZU
20"	14"	MAB2014M/ZBN	MAB2014M/Z	MAB2014M/ZU
	16"	MAB2016M/ZBN	MAB2016M/Z	MAB2016M/ZU
	18"	MAB2018M/ZBN	MAB2018M/Z	MAB2018M/ZU
22"	14"	MAB2214M/ZBN	MAB2214M/Z	MAB2214M/ZU
	16"	MAB2216M/ZBN	MAB2216M/Z	MAB2216M/ZU
	18"	MAB2218M/ZBN	MAB2218M/Z	MAB2218M/ZU
	20"	MAB2220M/ZBN	MAB2220M/Z	MAB2220M/ZU
24"	14"	MAB2414M/ZBN	MAB2414M/Z	MAB2414M/ZU
	16"	MAB2416M/ZBN	MAB2416M/Z	MAB2416M/ZU
	18"	MAB2418M/ZBN	MAB2418M/Z	MAB2418M/ZU
<b>Floor Toms</b>				
14"	12"	MAF1412BN	MAF1412	MAF1412U
	14"	MAF1414BN	MAF1414	MAF1414U
16"	14"	MAF1614BN	MAF1614	MAF1614U
	16"	MAF1616BN	MAF1616	MAF1616U
18"	16"	MAF1816BN	MAF1816	MAF1816U
<b>Tom Toms</b>				
8"	6"	MAT0806BN	MAT0806	MAT0806U
	7"	MAT0807BN	MAT0807	MAT0807U
	8"	MAT0808BN	MAT0808	MAT0808U
10"	6.5"	MAT1065BN	MAT1065	MAT1065U
	7"	MAT1007BN	MAT1007	MAT1007U
	8"	MAT1008BN	MAT1008	MAT1008U
12"	9"	MAT1009BN	MAT1009	MAT1009U
	7"	MAT1207BN	MAT1207	MAT1207U
	8"	MAT1208BN	MAT1208	MAT1208U
13"	9"	MAT1209BN	MAT1209	MAT1209U
	10"	MAT1210BN	MAT1210	MAT1210U
	7.5"	MAT1375BN	MAT1375	MAT1375U
14"	9"	MAT1309BN	MAT1309	MAT1309U
	10"	MAT1310BN	MAT1310	MAT1310U
	11"	MAT1311BN	MAT1311	MAT1311U
16"	10"	MAT1410BN	MAT1410	MAT1410U
	11"	MAT1411BN	MAT1411	MAT1411U
	12"	MAT1412BN	MAT1412	MAT1412U
16"	13"	MAT1613BN	MAT1613	MAT1613U
	14"	MAT1614BN	MAT1614	MAT1614U
<b>Snare Drums</b>				
13"	6"	MAS136BN	MAS136	MAS136U
	5.5"	MAS1455BN	MAS1455	MAS1455U
	6.5"	MAS1465BN	MAS1465	MAS1465U
14"	8"	MAS148BN	MAS148	MAS148U

**SPECIFICATIONS**

- Shells: All Maple TT/FT: 6ply 5mm, BD/SD: 8ply 7mm
- Star-Cast Mounting System
- Quick-Lock Tom Bracket
- EVANS® Heads
- Die-Cast Hoops
- Hold Tight™ Washers
- Claw Hooks w/ Rubber Spacers
- Cushioned Floor Tom Legs

**OPTION**



**MODEL NUMBER SYSTEM - Individual Drums**

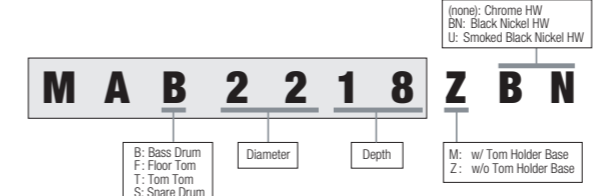

**MODEL NUMBER SYSTEM - Shell Kits**

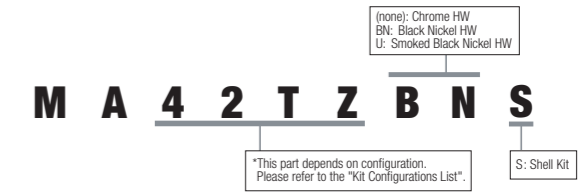



# STARCLASSIC PERFORMER B/B

-Premium Lacquer Finishes

The distinct and traditional sound of birch has made it the go-to choice for many pro drummers over the last 30 years. TAMA believes it's time to take birch in an entirely new direction. By using bubinga wood as the inner plies of a birch shell, TAMA has created a blended shell that provides a new sound featuring the focused attack of birch, and the enhanced lows of bubinga.



**COLOR** Gun Metal Classic Stripe -GMS

### PP52HZS basic kit

including:  
 18"x22" bass drum  
 6.5"x10" tom tom  
 7"x12" tom tom  
 12"x14" floor tom  
 14"x16" floor tom  
 MC69 single tom attachments (x2)

[add-on]  
 5.5"x14" snare drum



**COLOR** Satin Pearl White -SPW

### PP42S basic kit

including:  
 18"x22" bass drum  
 8"x10" tom tom  
 9"x12" tom tom  
 14"x16" floor tom  
 MTH1000 double tom holder

[add-on]  
 5.5"x14" snare drum

## KIT CONFIGURATIONS LIST

### PP42S 4pc Shell Kit in Premium Lacquer Finishes

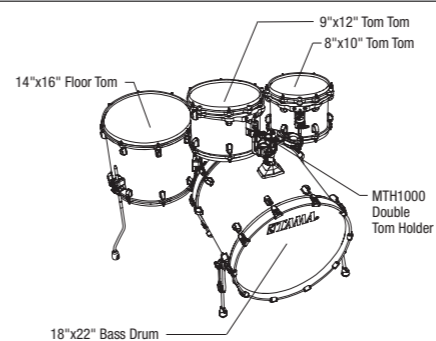

\*To order the kit with 5.5"x14" snare drum, use PP52S.

### PP52HZS 5pc Shell Kit in Premium Lacquer Finishes

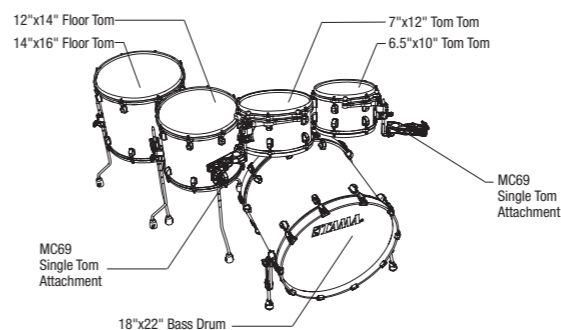

\*To order the kit with 5.5"x14" snare drum, use PP62HZS.

### PP32RZS 3pc Shell Kit in Premium Lacquer Finishes

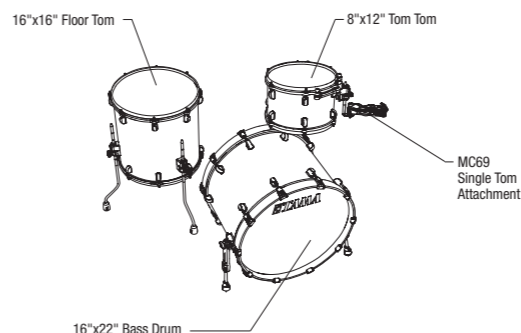

## INDIVIDUAL MODEL NUMBERS

Bass Drums		
Diameter	Depth	Model No.
20"	16"	PPB20DM/Z
	18"	PPB20EM/Z
22"	16"	PPB22DM/Z
	18"	PPB22EM/Z
	20"	PPB22XM/Z
24"	16"	PPB24DM/Z
	18"	PPB24EM/Z

Floor Toms		
Diameter	Depth	Model No.
14"	12"	PPF14A
	14"	PPF14D
16"	14"	PPF16A
	16"	PPF16D
18"	16"	PPF18D

Tom Toms		
Diameter	Depth	Model No.
8"	6"	PPT8H
	7"	PPT8A
10"	6.5"	PPT10H
	7"	PPT10R
	8"	PPT10A
12"	7"	PPT12H
	8"	PPT12R
	9"	PPT12A
13"	7.5"	PPT13H
	9"	PPT13R
	10"	PPT13A
14"	11"	PPT14A
	12"	PPT14D
16"	13"	PPT16A
	14"	PPT16D

Snare Drums		
Diameter	Depth	Model No.
13"	6"	PPS136
14"	5.5"	PPS55
	6.5"	PPS65

## SPECIFICATIONS

- Shells  
 TT/FT: 4ply Birch +3 inner ply Bubinga, 6mm  
 BD/SD: 5ply Birch + 3 inner ply Bubinga, 7mm
- Star-Cast Mounting System
- Quick-Lock Tom Bracket
- Die-Cast Hoops
- EVANS® Heads (on batter side)
- Claw Hooks w/ Rubber Spacers
- Cushioned Floor Tom Legs

### Tom Holder

**MTH1000**  
 (US. PAT. NO. 9087498)

Starclassic Performer B/B's tom holder expands on its setup flexibility with this "Swivel-Wing Tom Holder" design.

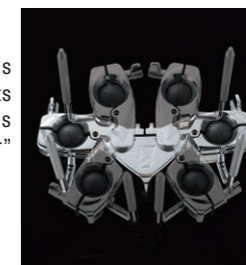

## FINISHES (Lacquer)



Gun Metal Classic Stripe -GMS  
 Coral Red Sparkle -CRD  
 Satin Pearl White -SPW  
 Black Clouds & Silver Linings -BCS  
 Blue Nebula Blaze -BNZ

## MODEL NUMBER SYSTEM - Individual Drums

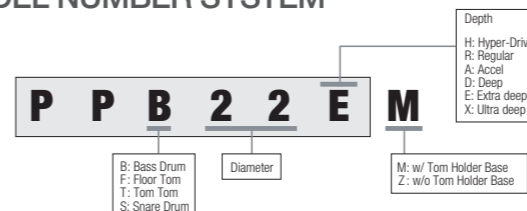

## MODEL NUMBER SYSTEM - Shell Kits

PP42S

\*This part depends on configuration. Please refer to the "Kit Configurations List".



# STARCLASSIC PERFORMER B/B -Lacquer Finishes



**COLOR** Lacquer Ocean Blue Ripple -LOR

### PS52HZS basic kit

including:  
 18"x22" bass drum  
 6.5"x10" tom tom  
 7"x12" tom tom  
 12"x14" floor tom  
 14"x16" floor tom  
 MC69 single tom attachments (x2)

[add-on]  
 6.5"x14" snare drum



**COLOR** Molten Brown Burst -MBR

### PS42S basic kit

including:  
 18"x22" bass drum  
 8"x10" tom tom  
 9"x12" tom tom  
 14"x16" floor tom  
 MTH1000 double tom holder

[add-on]  
 5.5"x14" snare drum

## FINISHES (Lacquer)



Lacquer Ocean Blue Ripple -LOR **NEW** Twilight Blue Burst -TWB Molten Brown Burst -MBR Cherry Natural Burst -CNT Smoky Indigo Burst -SIB

## KIT CONFIGURATIONS LIST

### PS42S 4pc Shell Kit in Lacquer Finishes

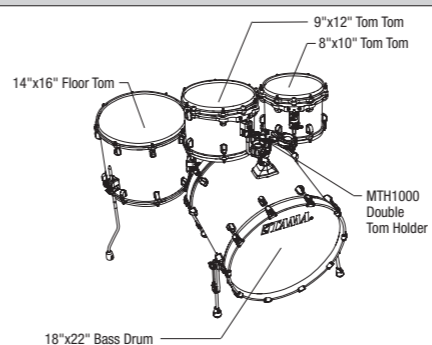

\*To order the kit with 5.5"x14" snare drum, use PS52S.

### PS52HZS 5pc Shell Kit in Lacquer Finishes

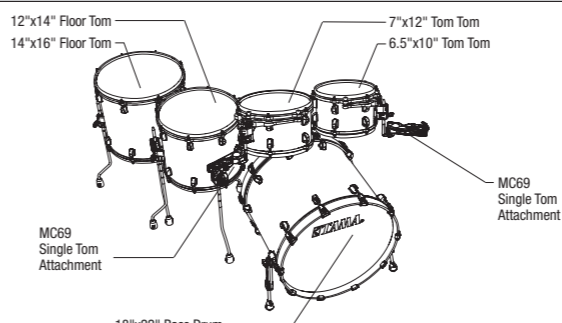

\*To order the kit with 5.5"x14" snare drum, use PS62HZS.

### PS32RZS 3pc Shell Kit in Lacquer Finishes

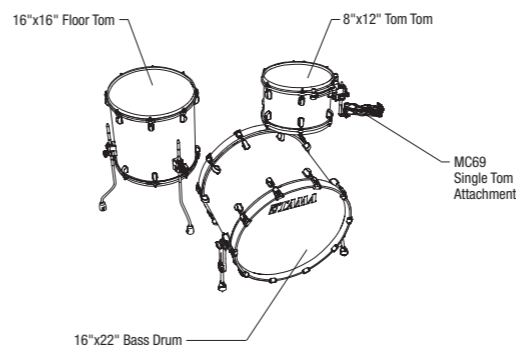

## INDIVIDUAL MODEL NUMBERS

Bass Drums		
Diameter	Depth	Model No.
20"	16"	PSB20DM/Z
	18"	PSB20EM/Z
22"	16"	PSB22DM/Z
	18"	PSB22EM/Z
	20"	PSB22XM/Z
24"	16"	PSB24DM/Z
	18"	PSB24EM/Z

Floor Toms		
Diameter	Depth	Model No.
14"	12"	PSF14A
	14"	PSF14D
16"	14"	PSF16A
	16"	PSF16D
18"	16"	PSF18D

Tom Toms		
Diameter	Depth	Model No.
8"	6"	PST8H
	7"	PST8A
10"	6.5"	PST10H
	7"	PST10R
	8"	PST10A
12"	7"	PST12H
	8"	PST12R
	9"	PST12A
13"	7.5"	PST13H
	9"	PST13R
	10"	PST13A
14"	11"	PST14A
	12"	PST14D
16"	13"	PST16A
	14"	PST16D

Snare Drums		
Diameter	Depth	Model No.
13"	6"	PSS136
14"	5.5"	PSS55
	6.5"	PSS65

## SPECIFICATIONS

- Shells  
 TT/FT: 4ply Birch +3 inner ply Bubinga, 6mm  
 BD/SD: 5ply Birch + 3 inner ply Bubinga, 7mm
- Star-Cast Mounting System
- Quick-Lock Tom Bracket
- Die-Cast Hoops
- EVANS® Heads (on batter side)
- Claw Hooks w/ Rubber Spacers
- Cushioned Floor Tom Legs

### Tom Holder

**MTH1000**  
 (US. PAT.NO.9087498)

Starclassic Performer B/B's tom holder expands on its setup flexibility with this "Swivel-Wing Tom Holder" design.

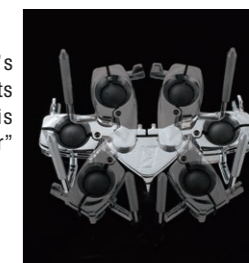

## MODEL NUMBER SYSTEM - Individual Drums

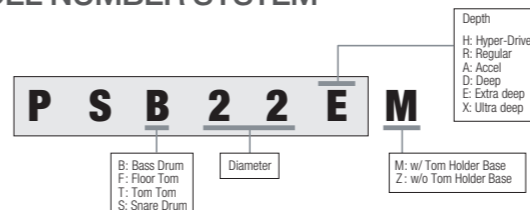

## MODEL NUMBER SYSTEM - Shell Kits

**PS42S**

\*This part depends on configuration. Please refer to the "Kit Configurations List".



# STARCLASSIC PERFORMER B/B -Duracover Wrap Finishes



**COLOR** Ice Blue Pearl -IBP

**PR32RZS basic kit**

including:  
 16"x22" bass drum  
 8"x12" tom tom  
 16"x16" floor tom  
 MC69 single tom attachment

[add-on]  
 6.5"x14" snare drum



**COLOR** Charcoal Onyx -CCO

**PR52HZS basic kit**

including:  
 18"x22" bass drum  
 6.5"x10" tom tom  
 7"x12" tom tom  
 12"x14" floor tom  
 14"x16" floor tom  
 MC69 single tom attachments (x2)

[add-on]  
 5.5"x14" snare drum

## KIT CONFIGURATIONS LIST

**PR42S 4pc Shell Kit in Duracover Wrap Finishes**

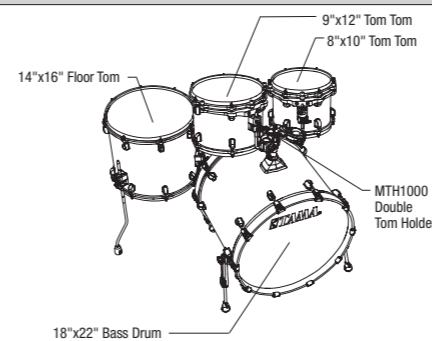

\*To order the kit with 5.5"x14" snare drum, use PR52S.

**PR52HZS 5pc Shell Kit in Duracover Wrap Finishes**

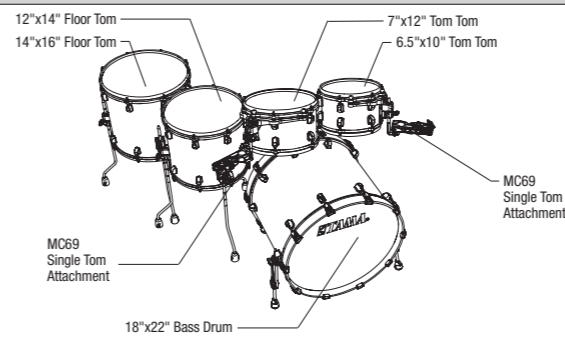

\*To order the kit with 5.5"x14" snare drum, use PR62HZS.

**PR32RZS 3pc Shell Kit in Duracover Wrap Finishes**

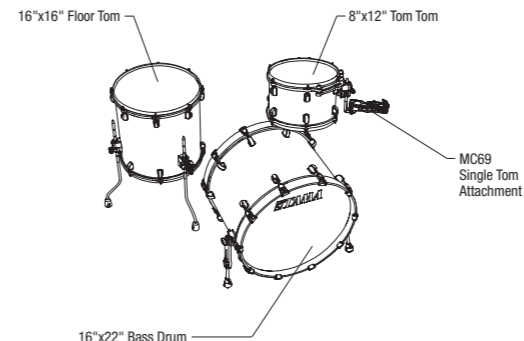

## INDIVIDUAL MODEL NUMBERS

Bass Drums		
Diameter	Depth	Model No.
20"	16"	PRB20DM/Z
	18"	PRB20EM/Z
22"	16"	PRB22DM/Z
	18"	PRB22EM/Z
	20"	PRB22XM/Z
24"	16"	PRB24DM/Z
	18"	PRB24EM/Z

Floor Toms		
Diameter	Depth	Model No.
14"	12"	PRF14A
	14"	PRF14D
16"	14"	PRF16A
	16"	PRF16D
18"	16"	PRF18D

Tom Toms		
Diameter	Depth	Model No.
8"	6"	PRT8H
	7"	PRT8A
10"	6.5"	PRT10H
	7"	PRT10R
	8"	PRT10A
12"	7"	PRT12H
	8"	PRT12R
	9"	PRT12A
13"	7.5"	PRT13H
	9"	PRT13R
	10"	PRT13A
14"	11"	PRT14A
	12"	PRT14D
16"	13"	PRT16A
	14"	PRT16D

Snare Drums		
Diameter	Depth	Model No.
13"	6"	PRS136
14"	5.5"	PRS55
	6.5"	PRS65

## SPECIFICATIONS

- Shells  
 TT/FT: 4ply Birch +3 inner ply Bubinga, 6mm  
 BD/SD: 5ply Birch + 3 inner ply Bubinga, 7mm
- Star-Cast Mounting System
- Quick-Lock Tom Bracket
- Die-Cast Hoops
- EVANS® Heads (on batter side)
- Claw Hooks w/ Rubber Spacers
- Cushioned Floor Tom Legs

### Tom Holder

**MTH1000**  
 (US. PAT.NO.9087498)

Starclassic Performer B/B's tom holder expands on its setup flexibility with this "Swivel-Wing Tom Holder" design.

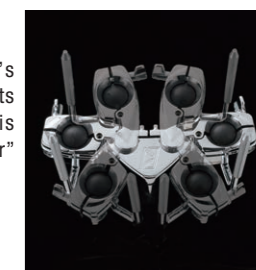

## FINISHES (Duracover Wrap)



## MODEL NUMBER SYSTEM - Individual Drums

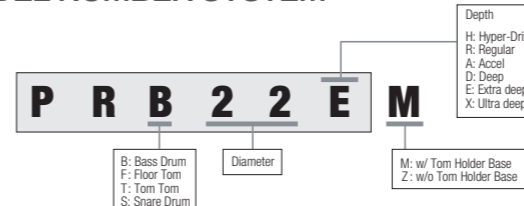

## MODEL NUMBER SYSTEM - Shell Kits

**P R 4 2 S**

\*This part depends on configuration. Please refer to the "Kit Configurations List".



# SUPERSTAR HYPER-DRIVE MAPLE

-Lacquer Finishes

Power. Flexibility. Visibility. With TAMA Hyper-Drive kits, your audience will hear your every note and see your every move. Hyper-Drive's unique combination of modern and traditional drum sizes offers sonic power with clarity, unparalleled set-up flexibility, and complete performance visibility.



**COLOR** Satin Arctic Pearl -SAP

**ML52HLZBNS 5pc basic kit**

- including:  
 18"x22" bass drum  
 6.5"x10" tom tom  
 7"x12" tom tom  
 12"x14" floor tom  
 14"x16" floor tom  
 MC69 single tom attachments (x2)

[add-on]  
 5.5"x14" snare drum



**COLOR** Classic Cherry Wine -CCW

**ML42HLZBNS 4pc basic kit**

- including:  
 18"x22" bass drum  
 6.5"x10" tom tom  
 7"x12" tom tom  
 14"x16" floor tom  
 MC69 single tom attachments (x2)

[add-on]  
 5.5"x14" snare drum



**COLOR** Flat Black -FBK

**ML52HLZBNS 5pc basic kit**

- including:  
 18"x22" bass drum  
 6.5"x10" tom tom  
 7"x12" tom tom  
 12"x14" tom tom  
 14"x16" floor tom  
 MC69 single tom attachments (x2)

[add-on]  
 5.5"x14" snare drum

## KIT CONFIGURATIONS LIST

**ML42HLZBNS 4pc Shell Kit without Snare in Lacquer Finishes** NEW

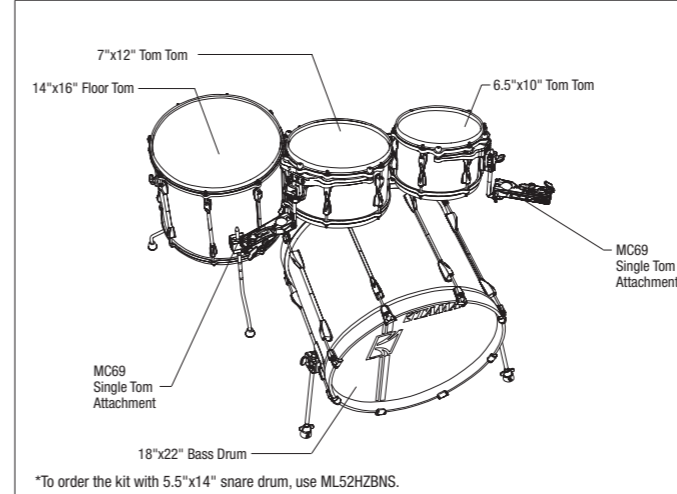

\*To order the kit with 5.5"x14" snare drum, use ML52HLZBNS.

**ML52HLZBNS 5pc Shell Kit without Snare in Lacquer Finishes** NEW

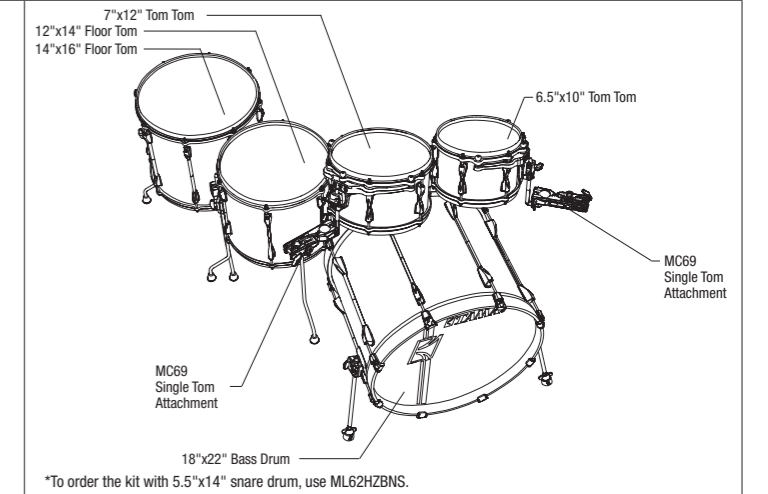

\*To order the kit with 5.5"x14" snare drum, use ML62HLZBNS.

## FINISHES (Lacquer)

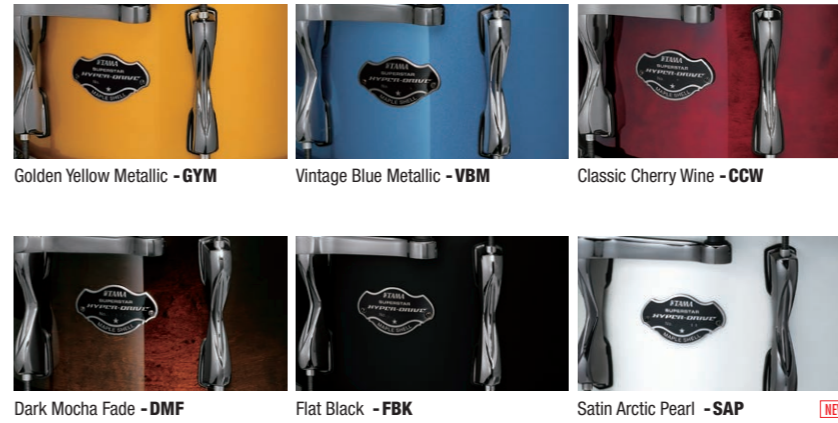

## INDIVIDUAL MODEL NUMBERS

Bass Drums	
Size	Model No.
18"x22"	MLB22EZBN
20"x22"	MLB22XZBN
18"x24"	MLB24EZBN
Floor Toms	
Size	Model No.
12"x14"	MLF14ABN
14"x16"	MLF16ABN
16"x18"	MLF18DBN
Tom Toms	
Size	Model No.
6"x8"	MLT8HBN
6.5"x10"	MLT10HBN
7"x12"	MLT12HBN
7.5"x13"	MLT13HBN
8"x14"	MLT14HBN
Snare Drums	
Size	Model No.
6"x13"	MLS136BN
5.5"x14"	MLS55BN
6.5"x14"	MLS65BN

## SPECIFICATIONS

- Shells  
All Maple  
(TT/FT/SD) 6ply, 5mm / (BD) 8ply, 7mm
- Black Nickel Shell Hardware
- Hyper-Drive Toms
- Star-Cast Mounting System in Black Nickel
- Power Craft II Drumheads
- Die-Cast Hoops
- Sound Bridge Hi-Tension Lugs

## SUPERSTAR HARDWARE KIT



- HB5W**  
 HS60W snare stand  
 HC63BW boom cymbal stands (x2)  
 HH205 Iron Cobra hi-hat stand  
 HP200P Iron Cobra single pedal



# SUPERSTAR HYPER-DRIVE MAPLE - Unicolor Wrap Finishes



**COLOR** Midnight Gold Sparkle -MGD

**MK52HLZBNS 5pc basic kit**

including:  
 18"x22" bass drum  
 6.5"x10" tom tom  
 7"x12" tom tom  
 12"x14" floor tom  
 14"x16" floor tom  
 MC69 single tom attachments (x2)

[add-on]  
 5.5"x14" snare drum



**COLOR** Bright Orange Sparkle -BOS

**MK42HLZBNS 4pc basic kit**

including:  
 18"x22" bass drum  
 6.5"x10" tom tom  
 7"x12" tom tom  
 14"x16" floor tom  
 MC69 single tom attachments (x2)

[add-on]  
 5.5"x14" snare drum



**COLOR** Sugar White -SGW

**MK52HLZBNS 5pc basic kit**

including:  
 18"x22" bass drum  
 6.5"x10" tom tom  
 7"x12" tom tom  
 12"x14" floor tom  
 14"x16" floor tom  
 MC69 single tom attachments (x2)

[add-on]  
 5.5"x14" snare drum

## KIT CONFIGURATIONS LIST

**MK42HLZBNS 4pc Shell Kit without Snare in Unicolor Wrap Finishes** NEW

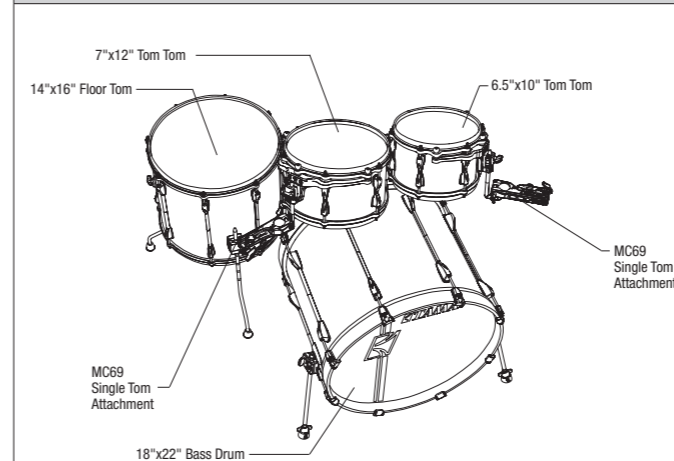

\*To order the kit with 5.5"x14" snare drum, use MK52HLZBNS.

**MK52HLZBNS 5pc Shell Kit without Snare in Unicolor Wrap Finishes** NEW

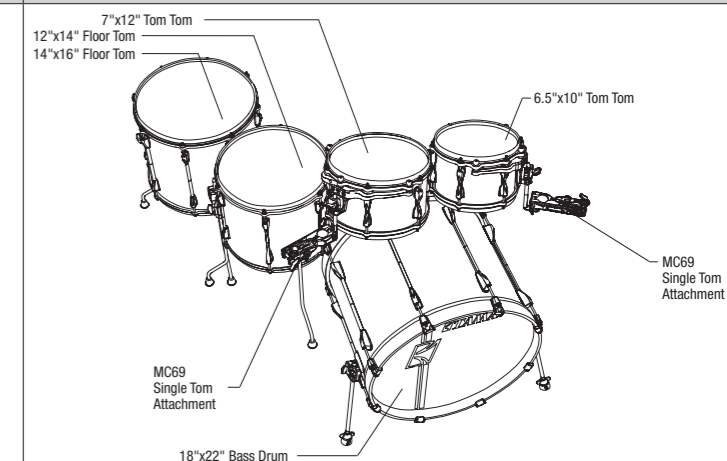

\*To order the kit with 5.5"x14" snare drum, use MK62HLZBNS.

## FINISHES (Unicolor Wrap)



Bright Orange Sparkle -BOS



Midnight Gold Sparkle -MGD



Indigo Sparkle -ISP



Brushed Charcoal Black -BCB



Sugar White -SGW

## INDIVIDUAL MODEL NUMBERS

Bass Drums	
Size	Model No.
18"x22"	MKB22EZBN
20"x22"	MKB22XZBN
18"x24"	MKB24EZBN
Floor Toms	
Size	Model No.
12"x14"	MKF14ABN
14"x16"	MKF16ABN
16"x18"	MKF18DBN
Tom Toms	
Size	Model No.
6"x8"	MKT8HBN
6.5"x10"	MKT10HBN
7"x12"	MKT12HBN
7.5"x13"	MKT13HBN
8"x14"	MKT14HBN
Snare Drums	
Size	Model No.
6"x13"	MKS136BN
5.5"x14"	MKS55BN
6.5"x14"	MKS65BN

## SPECIFICATIONS

- Shells  
All Maple  
(TT/FT/SD) 6ply, 5mm / (BD) 8ply, 7mm
- Black Nickel Shell Hardware
- Hyper-Drive Toms
- Star-Cast Mounting System in Black Nickel
- Power Craft II Drumheads
- Die-Cast Hoops
- Sound Bridge Hi-Tension Lugs

## SUPERSTAR HARDWARE KIT



**HB5W**  
 HS60W snare stand  
 HC63BW boom cymbal stands (x2)  
 HH205 Iron Cobra hi-hat stand  
 HP200P Iron Cobra single pedal



# SILVERSTAR

-Lacquer Finishes

The TAMA Silverstar drum kit delivers the quality and sound you expect from more expensive drums, but at a price that you can afford. Birch shells, Sound Arc Hoops, a Star-Mount system, and a slidable tom holder make this the kit of choice for the creative musician. With a wide variety of drum sizes and kit configurations, you have an open ended sonic palette to create the new sound of your dreams!



**COLOR** Vintage Gold Duco -VGD

### VP62RS basic kit

including:  
 18"x22" bass drum  
 7"x10" tom tom  
 8"x12" tom tom  
 12"x14" floor tom  
 14"x16" floor tom  
 5"x14" snare drum  
 MTH905N double tom holder

## KIT CONFIGURATIONS LIST

### VP62RS 6pc Shell Kit in Lacquer Finishes

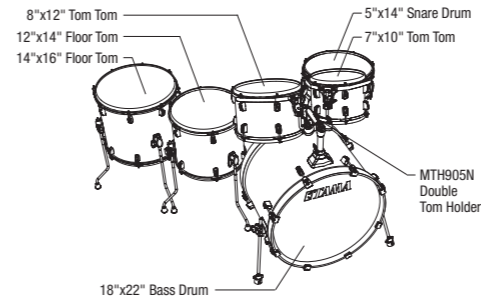

### VP52KRS 5pc Shell Kit in Lacquer Finishes

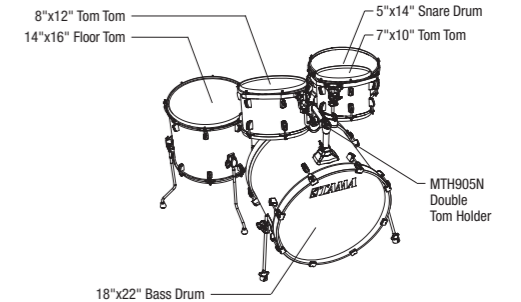

### VP50RS 5pc Shell Kit in Lacquer Finishes

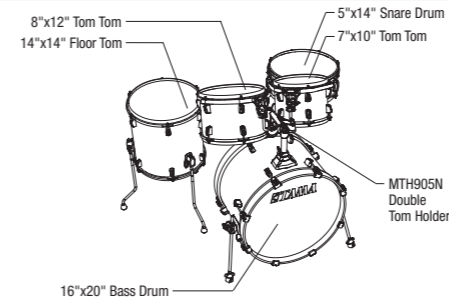

### VP48S 4pc Shell Kit in Lacquer Finishes

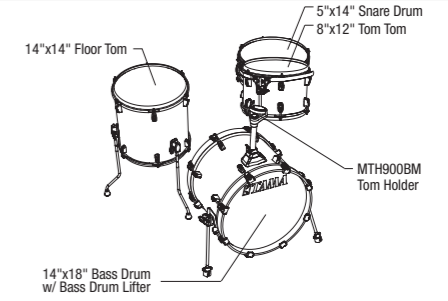

**COLOR** Antique Brown Burst -ABR

### VP52KRS basic kit

including:  
 18"x22" bass drum  
 7"x10" tom tom  
 8"x12" tom tom  
 14"x16" floor tom  
 5"x14" snare drum  
 MTH905N double tom holder

## FINISHES (Lacquer)



Vintage Gold Duco -VGD

**NEW** Jet Blue Burst -JTB

Antique Brown Burst -ABR

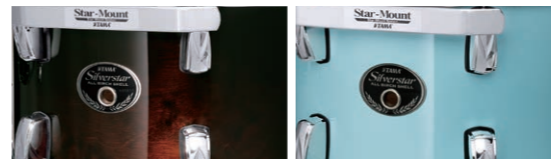

Dark Mocha Fade -DMF

Light Blue Lacquer -LBL

## INDIVIDUAL MODEL NUMBERS

Bass Drums	
Size	Model No.
14"x18"*	VPB18RL
16"x20"	VPB20D
18"x22"	VPB22E
18"x24"	VPB24E
Floor Toms	
Size	Model No.
12"x14"	VPF14A
14"x14"	VPF14D
14"x16"	VPF16A
16"x18"	VPF18D
Tom Toms	
Size	Model No.
6"x8"	VPT8H
7"x10"	VPT10R
8"x12"	VPT12R
9"x13"	VPT13R
10"x14"	VPT14R
Snare Drums	
Size	Model No.
5"x14"	VPS145
6.5"x14"	VPS1465

\* w/ Bass Drum Lifter

## SPECIFICATIONS

- Shells  
All Birch  
(TT/FT/SD) 6ply, 6mm / (BD) 7ply, 8mm
- Star-Mount System  
The Star-Mount System was developed to increase the resonance of drums. This mounting system provides support at four points on the batter side hoop of a drum.
- Sound Arc Hoops
- Low-Mass Lugs
- Slidable Tom Holder
- Claw Hooks w/ Rubber Spacers
- Bass Drum Lifter  
(18" Bass Drum)

### BASS DRUM LIFTER for 18" bass drum



## SILVERSTAR HARDWARE KIT

- HS60W** snare stand
- HC63BW** boom cymbal stands (x2)
- HH205** Iron Cobra hi-hat stand
- HP200P** Iron Cobra single pedal





**COLOR** Bright Orange Sparkle -BOS

**VD62RS basic kit**

including:  
 18"x22" bass drum  
 7"x10" tom tom  
 8"x12" tom tom  
 12"x14" floor tom  
 14"x16" floor tom  
 5"x14" snare drum  
 MTH905N double tom holder

**KIT CONFIGURATIONS LIST**

<p><b>VD62RS 6pc Shell Kit in Unicolor Wrap Finishes</b></p>	<p><b>VD52KRS 5pc Shell Kit in Unicolor Wrap Finishes</b></p>	<p><b>VD50RS 5pc Shell Kit in Unicolor Wrap Finishes</b></p>
<p><b>VD48S 4pc Shell Kit in Unicolor Wrap Finishes</b></p>	<p><b>VD36MWS "Metro-JAM" Kit in Unicolor Wrap Finishes</b></p>	<p><b>VD46CBN "Cocktail-JAM" Kit in Unicolor Wrap Finishes</b></p>



**COLOR** Matte Copper Sparkle -MCS

**VD36MWS "Metro-JAM" kit**

including:  
 14"x16" bass drum w/ bass drum lifter  
 6.5"x10" tom tom  
 11"x13" floor tom  
 MTH900BM single tom holder

[add-on]  
 5.5"x14" S.L.P. "Classic Maple" snare drum

**BASS DRUM LIFTER**  
 for 16" bass drum  
 (US. PAT.NO.9082377)



**FINISHES (Unicolor Wrap)**

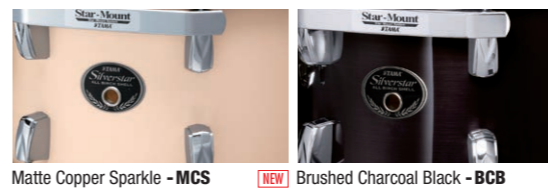

**INDIVIDUAL MODEL NUMBERS**

Bass Drums	
Size	Model No.
14"x16"*	VDB16RWL
14"x18"*	VDB18RL
16"x20"	VDB20D
18"x22"	VDB22E
18"x24"	VDB24E
Floor Toms	
Size	Model No.
11"x13"	VDF13A
12"x14"	VDF14A
14"x14"	VDF14D
14"x16"	VDF16A
16"x18"	VDF18D
Tom Toms	
Size	Model No.
6"x8"	VDT8H
7"x10"	VDT10R
8"x12"	VDT12R
9"x13"	VDT13R
10"x14"	VDT14R
Snare Drums	
Size	Model No.
5"x14"	VDS145
6.5"x14"	VDS1465

\* w/ Bass Drum Lifter



**EVANS® EMAD HEAD**



**DRUM BAG & HARDWARE BAG**



**COLOR** Indigo Sparkle -ISP

**VD46CBN "Cocktail-JAM" kit**  
 (US. PAT.NO.8927842)

6"x16" bass drum  
 5"x10" tom tom  
 5.5"x14" floor tom  
 5"x12" snare drum  
 single pedal  
 single tom attachments (x2)  
 drum bag  
 hardware bag  
 Hardware & Accessories:  
 [MCAX5366 clamp kit] including cymbal attachment, hi-hat attachment.

\*To order the complete kit with MCAX5366, please use the model number below.  
**VD46CBCN**

**SPECIFICATIONS**

- Shells  
 All Birch  
 (TT/FT/SD) 6ply, 6mm / (BD) 7ply, 8mm
- Star-Mount System  
 The Star-Mount System was developed to increase the resonance of drums. This mounting system provides support at four points on the batter side hoop of a drum.
- Sound Arc Hoops
- Low-Mass Lug
- Slidable Tom Holder
- Claw Hooks w/ Rubber Spacers
- Bass Drum Lifter  
 (16" & 18" Bass Drum)



**SILVERSTAR HARDWARE KIT**

- HB5W**  
**HS60W** snare stand  
**HC63BW** boom cymbal stands (x2)  
**HH205** Iron Cobra hi-hat stand  
**HP200P** Iron Cobra single pedal



With nearly 40 years of drum building experience, TAMA knows what drummers really want. With this in mind we sought out to design an affordable yet durable kit that retained many high-end features you'll find in our Silverstar, Superstar, and Starclassic lines. What we came up with was Imperialstar. Every aspect of the modern drum kit was exhaustively examined, reexamined, and then improved before it was accepted as part of the Imperialstar design.



## 22" BASS DRUM KIT

**COLOR** **Blacked Out Black - BB0B**  
w/ black nickel hardware

### IP52KH6N

**Drums:** 18"x22" bass drum, 8"x10" & 9"x12" tom toms, 14"x16" floor tom, 5"x14" snare drum.  
**Hardware:** double tom holder, hi-hat stand, drum pedal, snare stand, boom cymbal stand, straight cymbal stand, drum throne.

### IP52KH6NC

\*MEINL "HCS" cymbals (14"HH+16"C+20"R) are added to IP52KH6N.

### IP52KH5N

\*without straight cymbal stand from IP52KH6N

### IP52KH4N

\*without drum throne from IP52KH5N



## 20" BASS DRUM KIT

**COLOR** **Vintage Red - BVTR**  
w/ black nickel hardware

### IP50H6N

**Drums:** 18"x20" bass drum, 8"x10" & 9"x12" tom toms, 14"x14" floor tom, 5"x14" snare drum.  
**Hardware:** double tom holder, hi-hat stand, drum pedal, snare stand, boom cymbal stand, straight cymbal stand, drum throne.

### IP50H6NC

\*MEINL "HCS" cymbals (14"HH+16"C+20"R) are added to IP50H6N.

### IP50H5N

\*without straight cymbal stand from IP50H6N

### IP50H4N

\*without drum throne from IP50H5N



## 18" BASS DRUM KIT

**COLOR** **Champagne Mist - CHM**  
w/ chrome hardware

### IP58H6N

**Drums:** 14"x18" bass drum w/bass drum lifter, 8"x10" & 9"x12" tom toms, 12"x14" floor tom, 5"x13" snare drum.  
**Hardware:** double tom holder, hi-hat stand, drum pedal, snare stand, boom cymbal stand, straight cymbal stand, drum throne.

### IP58H6NC

\*MEINL "HCS" cymbals (14"HH+16"C+20"R) are added to IP58H6N.

### IP58H5N

\*without straight cymbal stand from IP58H6N

### IP58H4N

\*without drum throne from IP58H5N

## KIT CONFIGURATIONS LIST

### IP62H6N 6pc Kit w/ Hardware in Unicolor Wrap Finishes NEW

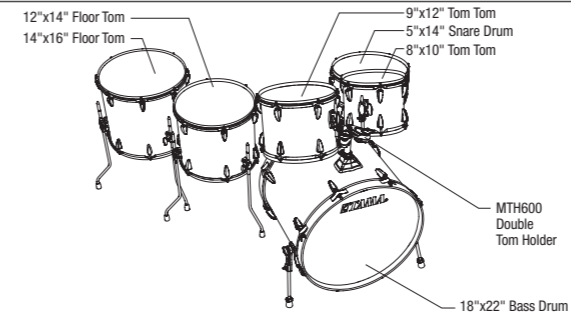

### IP52KH6N 5pc Kit w/ Hardware in Unicolor Wrap Finishes

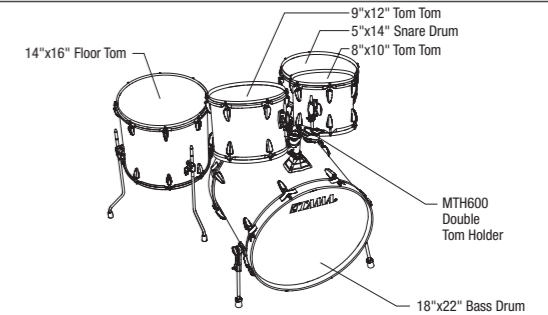

### IP50H6N 5pc Kit w/ Hardware in Unicolor Wrap Finishes

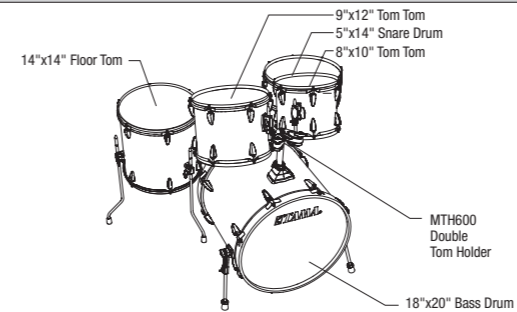

### IP58H6N 5pc Kit w/ Hardware in Unicolor Wrap Finishes

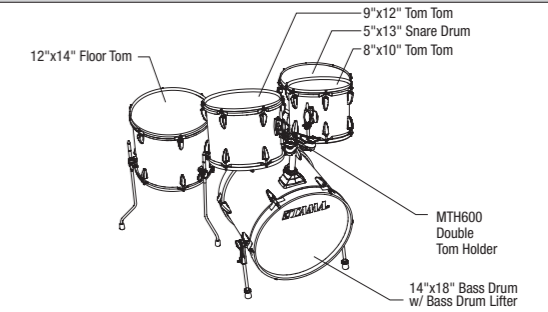

## FINISHES (Unicolor Wrap)

### with Black Nickel Hardware



Blacked Out Black - BB0B NEW Vintage Red - BVTR Sugar White - BSGW

### with Chrome Hardware



Champagne Mist - CHM NEW Midnight Blue - MNB Hairline Black - HBK

## SPECIFICATIONS

- Shells  
All Poplar 8ply 7.5mm
- TAMA Precision Bearing Edges
- Wraps-glued to the shell
- Omnisphere Tom Holder
- Accu-Tune Bass Drum Hoops
- STAGE MASTER Hardware
- Durable Drum Heads
- Bass Drum Lifter (18" BD)
- HP200P Iron Cobra Drum Pedal



## MEINL HCS Cymbals

With 6pc hardware kit, you can upgrade to MEINL's "HCS" high quality brass cymbals, which raises the bar yet another notch.  
\*These cymbals are not available separately.  
\*\*To order the Meinl HCS cymbal package, please add "C" to the model number.  
ex) IP52KH6N — IP52KH6NC



## INDIVIDUAL MODEL NUMBERS

Bass Drums	
Size	Model No.
14"x18"	IPB18RL*
18"x20"	IPB20E
18"x22"	IPB22E
Floor Toms	
Size	Model No.
12"x14"	IPF14A
14"x14"	IPF14D
14"x16"	IPF16A
16"x16"	IPF16D
16"x18"	IPF18D
Tom Toms	
Size	Model No.
7"x8"	IPT8A
8"x10"	IPT10A
9"x12"	IPT12A
10"x13"	IPT13A
Snare Drums	
Size	Model No.
5"x13"	IPS135
5"x14"	IPS145
6.5"x14"	IPS1465

\*w/ Bass Drum Lifter

## BASS DRUM LIFTER for 18" bass drum





# RHYTHM MATE

TAMA's entry-level Rhythm Mate drum kit provides the precise bearing edges for easy tuning that beginners need and the wide tuning range that pros demand. TAMA's original Accu-Tune Bass Drum Hoops offer faster, more consistent tuning than traditional metal hoops. And if that wasn't enough, the hardware is equipped with double-braced legs for increased stability. TAMA Rhythm Mate drums are changing the way entry-level kits are designed.



## 22" BASS DRUM KIT

**COLOR** Red Stream -RDS

### RM52KH6

**Drums:** 16"x22" bass drum, 7"x10" & 8"x12" tom toms, 15"x16" floor tom, 5"x14" snare drum.

**Hardware:** double tom holder, hi-hat stand, drum pedal, snare stand, boom cymbal stand, straight cymbal stand, drum throne.

### RM52KH5

\*without boom cymbal stand from RM52KH6

### RM52KH4

\*without drum throne from RM52KH5

## 20" BASS DRUM KIT

**COLOR** Black -BK

### RM50YH6

**Drums:** 16"x20" bass drum, 7"x10" & 8"x12" tom toms, 13"x14" floor tom, 5"x14" snare drum.

**Hardware:** double tom holder, hi-hat stand, drum pedal, snare stand, boom cymbal stand, straight cymbal stand, drum throne.

### RM50YH5

\*without boom cymbal stand from RM50YH6

### RM50YH4

\*without drum throne from RM50YH5

## Add-on Cymbals

To order the kit with cymbals, please add "C" to the model number.  
ex) RM52KH6 --- RM52KH6C

## FINISHES (Unicolor Wrap)



Red Stream -RDS Galaxy Silver -GXS Charcoal Mist -CCM Wine Red -WR White -WH Black -BK

## SPECIFICATIONS

- Shells  
All Poplar 9ply 7.5mm
- TAMA Precision Bearing Edges
- Wraps-glued to the shell
- Omnisphere Tom Holder
- Accu-Tune Bass Drum Hoops
- Double Braced Leg Hardware
- Chain Drive Drum Pedal





# SNARE DRUMS

TAMA has a wide variety of snare drum options to complement our array of drum kits. From our super high end STAR snare drums to the Soundworks series, which offers quality at a great price, there is a model to fit every drummer's desired sound and budget.



TAMA STAR



Color: Dark Green Cordia -CDKG

## BUBINGA

### TBS136D MADE IN JAPAN

Shell: 4.5mm, 1 inner ply Cordia + 5 outer ply Bubinga + 1 outer ply Cordia w/ 9mm Sound Focus Rings  
Size (Basic Model No.): 8"x14" (TBS148), 6.5"x14" (TBS1465), 5.5"x14" (TBS1455), 6"x13" (TBS136)  
Lug: MSL90S  
Hoop: Die-Cast Hoop (8 hole)  
Strainer/Butt: MSL50A (US. PAT. NO. 8017846) / MSL50B  
Snare Wire: 14" = MS20RL14C, 13" = MS20RL13C  
[Available Colors] Please see P8  
[Inlay Option] Outside Inlay, Inside & Outside Inlay, or w/o Inlay



Color: Satin Antique Brown -SAB

## MAPLE

### TMS1465S MADE IN JAPAN

Shell: 5mm, 5ply Maple w/ 5mm Sound Focus Rings  
Size (Basic Model No.): 8"x14" (TMS148), 6.5"x14" (TMS1465), 5.5"x14" (TMS1455), 6"x13" (TMS136)  
Lug: MSL90S  
Hoop: Die-Cast Hoop (8 hole)  
Strainer/Butt: MSL50A / MSL50B  
Snare Wire: 14" = MS20RL14C, 13" = MS20RL13C  
[Available Colors] Please see P10  
[Inlay Option] Outside Inlay, Inside & Outside Inlay, or w/o Inlay

## WALNUT

### TWS1455 MADE IN JAPAN

Shell: 5mm, 6ply Walnut  
Size (Basic Model No.): 8"x14" (TWS148), 6.5"x14" (TWS1465), 5.5"x14" (TWS1455), 6"x13" (TWS136)  
Lug: MSL90S  
Hoop: Die-Cast Hoop (8 hole)  
Strainer/Butt: MSL50A / MSL50B  
Snare Wire: 14" = MS20RL14C, 13" = MS20RL13C  
[Available Colors] Please see P12



Color: Satin Black Walnut -WSBN

## SOLID MAHOGANY

### TLH146S MADE IN JAPAN

Shell: 7mm Solid Mahogany w/ 7mm Sound Focus Rings  
Size: 6"x14"  
Lug: MSL90S  
Hoop: Die-Cast Hoop (8 hole)  
Strainer/Butt: MSL50A / MSL50B  
Snare Wire: MS20RL14C  
[Available Color] Oiled Natural Mahogany (OMH) only  
[Inlay Option] Outside Inlay, or w/o Inlay



## STAVE WALNUT

### TVW146S MADE IN JAPAN

Shell: 10mm, 16pcs Stave Walnut  
Size: 6"x14"  
Lug: MSL90S  
Hoop: Die-Cast Hoop (8 hole)  
Strainer/Butt: MSL50A / MSL50B  
Snare Wire: MS20RL14C  
[Available Color] Oiled Natural Walnut (OWN) only  
[Inlay Option] Outside Inlay, or w/o Inlay



## SOLID MAPLE

### TLM145S MADE IN JAPAN NEW

Shell: 8mm Solid Maple w/ 8mm Solid Maple Sound Focus Rings  
Size: 5"x14"  
Lug: MTL150  
Hoop: 2.3mm Brass Sound Arc Hoop (8 hole)  
Strainer/Butt: MSL50A / MSL50B  
Snare Wire: Super Sensitive Hi-Carbon Snare Wire for Concert  
[Available Color] Oiled Natural Maple (OMP) only



## SOLID ZEBRAWOOD

### TLZ146S MADE IN JAPAN

Shell: 7mm Solid Zebrawood w/ 7mm Sound Focus Rings  
Size: 6"x14"  
Lug: MSL90S  
Hoop: Die-Cast Hoop (8 hole)  
Strainer/Butt: MSL50A / MSL50B  
Snare Wire: MS20RL14C  
[Available Color] Oiled Natural Zebrawood (OZW) only  
[Inlay Option] Outside Inlay, or w/o Inlay



## SOLID MAPLE

### TLM146S MADE IN JAPAN

Shell: 8mm Solid Maple w/ 8mm Sound Focus Rings  
Size: 6"x14"  
Lug: MSL90S  
Hoop: Die-Cast Hoop (8 hole)  
Strainer/Butt: MSL50A / MSL50B  
Snare Wire: MS20RL14C  
[Available Color] Oiled Natural Maple (OMP) only  
[Inlay Option] Outside Inlay, or w/o Inlay



## STAVE ASH

### TVA146S MADE IN JAPAN

Shell: 10mm, 16pcs Stave Ash  
Size: 6"x14"  
Lug: MSL90S  
Hoop: Die-Cast Hoop (8 hole)  
Strainer/Butt: MSL50A / MSL50B  
Snare Wire: MS20RL14C  
[Available Color] Oiled Natural Ash (OAS) only  
[Inlay Option] Outside Inlay, or w/o Inlay



## BUBINGA/MAPLE

### TMB158S MADE IN JAPAN NEW

Shell: 5.5mm, 8ply Maple/Bubinga (1 inner ply Cordia + 2ply Bubinga + 4ply Maple + 1outer ply Olive Ash)  
Size: 8"x15"  
Lug: MSL90T  
Hoop: Brass Mighty Hoop (8 hole)  
Strainer/Butt: MSL50A / MSL50B  
Snare Wire: MS20SN15S  
[Available Color] Caramel Olive Ash Burst (OCOB) only



TAMA STAR RESERVE

STARPHONIC

STARCLASSIC



## WALNUT/BUBINGA

### TBWS1465S MADE IN JAPAN NEW

Shell: 5.5mm, 7ply Walnut / Bubinga (4ply Walnut + 2ply Bubinga + 1 outer ply Claro Walnut) w/ Maple Sound Focus Rings  
Size: 6.5"x14"  
Lug: MTL160  
Hoop: Sound Arc Hoop (10 Hole)  
Strainer/Butt: MSL50A / MSL50B  
Snare Wire: MS20RL14C  
[Available Color] Gloss Claro Walnut (GCW) only



## MAPLE

### PMM146 MADE IN JAPAN

Shell: 6mm, 6ply Maple + 1 outer ply Mappa Burl  
Size: 6"x14"  
Lug: Freedom Lug (US. PAT. NO. 7825318)  
Hoop: Grooved Hoop  
Strainer/Butt: MSL50A / MSL50B  
Snare Wire: MS20RL14C  
Color: Satin Mappa Burl - STM



## BRASS

### PBR146 MADE IN JAPAN

Shell: 1.2mm Brass  
Size: 6"x14"  
Lug: Freedom Lug  
Hoop: Grooved Hoop  
Strainer/Butt: MSL50A / MSL50B  
Snare Wire: MS20RL14C



## ALUMINUM

### PAL146 MADE IN JAPAN

Shell: 1.2mm Seamless Aluminum  
Size: 6"x14"  
Lug: Freedom Lug  
Hoop: Grooved Hoop  
Strainer/Butt: MSL50A / MSL50B  
Snare Wire: MS20RL14C



## STEEL

### PST146 MADE IN JAPAN

Shell: 1mm Steel  
Size: 6"x14"  
Lug: Freedom Lug  
Hoop: Grooved Hoop  
Strainer/Butt: MSL50A / MSL50B  
Snare Wire: MS20RL14C



## BUBINGA OMNI-TUNE

### SOS1455T MADE IN JAPAN

Shell: 8mm, 9ply Bubinga  
Size (Basic Model No.): 6.5"x14" (SOS1465T), 5.5"x14" (SOS1455T)  
Lug: Omni-Tune Lug (US. PAT. NO. 6963022)  
Hoop: Die-Cast Hoop (10 hole)  
Strainer/Butt: MUS80AH / MUS80BH  
Snare Wire: MS20SN14S  
[Available Colors] Sunny Yellow Lacquer (SYL), Natural Bubinga (NBG), Piano White (PWH), Piano Black (PBK)  
\*Brushed Nickel plated shell hardware only



## BUBINGA

### PBC146 MADE IN JAPAN

Shell: 7mm, 8ply Bubinga + 1 outer ply Cordia  
Size: 6"x14"  
Lug: Freedom Lug  
Hoop: Grooved Hoop  
Strainer/Butt: MSL50A / MSL50B  
Snare Wire: MS20RL14C  
Color: Matte Natural Cordia - MNC



## BELL BRASS

### PBB146 MADE IN JAPAN

Shell: 3mm Bell Brass  
Size: 6"x14"  
Lug: Freedom Lug  
Hoop: Grooved Hoop  
Strainer/Butt: MSL50A / MSL50B  
Snare Wire: MS20RL14C



## STAINLESS STEEL

### PSS146 MADE IN JAPAN

Shell: 1mm Stainless Steel w/ R.S.E.  
Size: 6"x14"  
Lug: Freedom Lug  
Hoop: Grooved Hoop  
Strainer/Butt: MSL50A / MSL50B  
Snare Wire: MS20RL14C



## STEEL

### PST137 MADE IN JAPAN

Shell: 1mm Steel  
Size: 7"x13"  
Lug: Freedom Lug  
Hoop: Grooved Hoop  
Strainer/Butt: MSL50A / MSL50B  
Snare Wire: MS20RL13C



## BUBINGA EXOTIC

### BES1465

Shell: 7mm, 8ply Bubinga + 1 outer ply Quilted Bubinga or Tigerwood  
Size (Basic Model No.): 8"x14" (BES148), 6.5"x14" (BES1465), 5.5"x14" (BES1455), 6"x13" (BES136)  
Lug: MSL-SCT  
Hoop: Die-Cast Hoop  
Strainer/Butt: MSL50A / MSL50B  
Snare Wire: 14" = MS20RL14C, 13" = MS20RL13C  
[Available Colors] Please see P20.  
[Parts Color Choice] Smoked Black Nickel(U), Black Nickel (B) or Chrome plated shell hardware is available.





Color: Satin Bubinga -SBG

**BUBINGA**

**BGS1465BN**

Shell: 7mm, 9ply Bubinga  
 Size (Basic Model No.): 8"x14" (BGS148), 6.5"x14" (BGS1465), 5.5"x14" (BGS1455), 6"x13" (BGS136)  
 Lug: MSL-SCT  
 Hoop: Die-Cast Hoop  
 Strainer/Butt: MLS50A/MLS50B  
 Snare Wire: 14"=MS20RL14C, 13"=MS20RL13C  
 [Available Colors] Please see P22, and also available in Satin Bubinga (SBG) natural matte finish.  
 [Parts Color Choice] Smoked Black Nickel (U), Black Nickel (BN) or Chrome plated shell hardware is available.



Color: Figured Carribean Blue Fade -GFCB

**MAPLE EXOTIC**

**MES1465B**

Shell: 7mm, 7ply Maple + 1 outer ply Figured Maple or Pacific Walnut  
 Size (Basic Model No.): 8"x14" (MES148), 6.5"x14" (MES1465), 5.5"x14" (MES1455), 6"x13" (MES136)  
 Lug: MSL-SCT  
 Hoop: Die-Cast Hoop  
 Strainer/Butt: MLS50A/MLS50B  
 Snare Wire: 14"=MS20RL14C, 13"=MS20RL13C  
 [Available Colors] Please see P24.  
 [Parts Color Choice] Smoked Black Nickel (U), Black Nickel (B) or Chrome plated shell hardware is available.



Color: Antique Maple -ATM

**MAPLE**

**MAS1455**

Shell: 7mm, 8ply Maple  
 Size (Basic Model No.): 8"x14" (MAS148), 6.5"x14" (MAS1455), 5.5"x14" (MAS1455), 6"x13" (MAS136)  
 Lug: MSL-SCT  
 Hoop: Die-Cast Hoop  
 Strainer/Butt: MLS50A/MLS50B  
 Snare Wire: 14"=MS20RL14C, 13"=MS20RL13C  
 [Available Colors] Please see P26, and also available in Antique Maple (ATM) natural matte finish.  
 [Parts Color Choice] Smoked Black Nickel (U), Black Nickel (BN) or Chrome plated shell hardware is available.



Color: Coral Red Sparkle -CRD

**PERFORMER B/B PREMIUM LACQUER FINISH**

**PPS55**

Shell: 7mm, 5ply Birch + 3 inner ply Bubinga or Pacific Walnut  
 Size (Basic Model No.): 6.5"x14" (PPS65), 5.5"x14" (PPS55), 6"x13" (PPS136)  
 Lug: MSL-SCT  
 Hoop: Die-Cast Hoop  
 Strainer/Butt: MCS70A/MCS70B  
 Snare Wire: 14"=MS20R14S, 13"=MS20R13S  
 [Available Colors] Please see P28.  
 \*Chrome plated shell hardware only



Color: Twilight Blue Burst -TWB

**PERFORMER B/B LACQUER FINISH**

**PSS55**

Shell: 7mm, 5ply Birch + 3 inner ply Bubinga  
 Size (Basic Model No.): 6.5"x14" (PSS65), 5.5"x14" (PSS55), 6"x13" (PSS136)  
 Lug: MSL-SCT  
 Hoop: Die-Cast Hoop  
 Strainer/Butt: MCS70A/MCS70B  
 Snare Wire: 14"=MS20R14S, 13"=MS20R13S  
 [Available Colors] Please see P30.  
 \*Chrome plated shell hardware only



Color: Ice Blue Pearl -IBP

**PERFORMER B/B DURACOVER WRAP FINISH**

**PRS65**

Shell: 7mm, 5ply Birch + 3 inner ply Bubinga  
 Size (Basic Model No.): 6.5"x14" (PRS65), 5.5"x14" (PRS55), 6"x13" (PRS136)  
 Lug: MSL-SCT  
 Hoop: Die-Cast Hoop  
 Strainer/Butt: MCS70A/MCS70B  
 Snare Wire: 14"=MS20R14S, 13"=MS20R13S  
 [Available Colors] Please see P32.  
 \*Chrome plated shell hardware only



**FAT SPRUCE**

**LSP146** NEW

Shell: 7mm, 8ply Spruce Shell  
 Size: 6"x14"  
 Lug: MTL60  
 Hoop: Die-Cast Hoop (8 hole)  
 Strainer/Butt: MLS50A/MLS50B  
 Snare Wire: MS20RL14C  
 Color: Wild Satin Spruce -WSS



**VINTAGE POPLAR MAPLE**

**LMPM1455F**

Shell: 6mm, 2 inner ply Maple + 2ply Poplar + 1ply Maple + 1 outer ply Figured Maple w/ Sound Focus Rings  
 Size: 5.5"x14"  
 Lug: MCHL5S  
 Hoop: Steel Mighty Hoop (8 hole)  
 Strainer/Butt: MLS50A/MLS50B  
 Snare Wire: MS20SN14S  
 Color: Natural Figured Maple -NFM



**CLASSIC MAPLE**

**LMP1455**

Shell: 7mm, 8ply Maple  
 Size: 5.5"x14"  
 Lug: MTL50  
 Hoop: Sound Arc Hoop (10 hole)  
 Strainer/Butt: MLS50A/MLS50B  
 Snare Wire: MS20RL14C  
 Color: Super Maple -SMP



**STUDIO MAPLE**

**LMP1465F**

Shell: 5mm, 6ply Maple w/ Sound Focus Rings  
 Size: 6.5"x14"  
 Lug: MSL-SCT  
 Hoop: 100% Maple Wood Hoop (8 hole)  
 Strainer/Butt: MLS50A/MLS50B  
 Snare Wire: MS20SN14S  
 Color: Sienna -SEN



**G-MAPLE**

**LGM137**

Shell: 10mm, 11ply Maple + 1 outer ply Tamo Ash  
 Size: 7"x13"  
 Lug: MTL60  
 Hoop: Die-Cast Hoop (8 hole)  
 Strainer/Butt: MLS50A/MLS50B  
 Snare Wire: MS20SN13C  
 Color: Satin Tamo Ash -STA



**G-WALNUT**

**LGW1465**

Shell: 9mm, 10ply Walnut  
 Size: 6.5"x14"  
 Lug: MTL60  
 Hoop: Sound Arc Hoop (10 hole)  
 Strainer/Butt: MLS50A/MLS50B  
 Snare Wire: MS30R14S  
 Color: Matte Black Walnut -MBW



**G-BUBINGA**

**LGB146**

Shell: 10mm, 1 ply Bubinga + 1 outer ply Quilted Bubinga  
 Size: 6"x14"  
 Lug: MSL-SCTBN  
 Hoop: Steel Mighty Hoop (10 hole)  
 Strainer/Butt: MLS50ABN/MLS50BBN  
 Snare Wire: MS20SN14S  
 Color: Natural Quilted Bubinga -NQB



**CLASSIC DRY ALUMINUM**

**LAL1455** NEW

Shell: 1.2mm Seamless Aluminum  
 Size: 5.5"x14"  
 Lug: MCHL5S  
 Hoop: Steel Mighty Hoop (8 hole)  
 Strainer/Butt: MCS70A/MCS70B  
 Snare Wire: MS20RL14C



**VINTAGE HAMMERED STEEL**

**LST1455H**

Shell: 1.2mm Hammered Steel  
 Size: 5.5"x14"  
 Lug: MTL50  
 Hoop: Sound Arc Hoop (10 hole)  
 Strainer/Butt: MCS70A/MCS70B  
 Snare Wire: MS20RL14C



**BLACK BRASS**

**LBR1465**

Shell: 1.5mm Brass  
 Size: 5.5"x14"  
 Lug: MSL-SCTBN  
 Hoop: Steel Mighty Hoop (10 hole)  
 Strainer/Butt: MCS70ABN/MCS70BBN  
 Snare Wire: MS20R14S



**BIG BLACK STEEL**

**LST148**

Shell: 1mm Steel in Matte Black Finish  
 Size: 8"x14"  
 Lug: MSL35BN  
 Hoop: Steel Mighty Hoop (10 hole)  
 Strainer/Butt: MCS70ABN/MCS70BBN  
 Snare Wire: MS20SN14S



**DYNAMIC BRONZE**

**LBZ1455**

Shell: 1.2mm Bronze  
 Size: 5.5"x14"  
 Lug: MTL50  
 Hoop: Die-Cast Hoop (10 hole)  
 Strainer/Butt: MCS70A/MCS70B  
 Snare Wire: MS20SN14C



**MAPLE**

**DMP1255**

Shell: 5mm, 6ply Maple  
 Size: 5.5"x12"  
 Lug: MSL60S  
 Hoop: Sound Arc Hoop (6 hole, 1.6mm)  
 Strainer/Butt: MCS70A/MCS70B  
 Snare Wire: MS20R12S  
 Color: Matte Vintage Maple -MVM



**MAPLE**

**DMP1465**

Shell: 5mm, 6ply Maple  
 Size: 5.5"x14"  
 Lug: MSL60S  
 Hoop: Sound Arc Hoop (10 hole)  
 Strainer/Butt: MCS70A/MCS70B  
 Snare Wire: MS20R14S  
 Color: Matte Vintage Maple -MVM



**KAPUR**

**DKP137**

Shell: 6mm, 7ply Kapur  
 Size: 7"x14"  
 Lug: MSL60S  
 Hoop: Sound Arc Hoop (8 hole)  
 Strainer/Butt: MCS70A/MCS70B  
 Snare Wire: MS20R13S  
 Color: Matte Brown Kapur -MRK



**KAPUR**

**DKP146**

Shell: 6mm, 7ply Kapur  
 Size: 6"x14"  
 Lug: MSL60S  
 Hoop: Sound Arc Hoop (10 hole)  
 Strainer/Butt: MCS70A/MCS70B  
 Snare Wire: MS20R14S  
 Color: Matte Brown Kapur -MRK



**STEEL**

**DST1055M**

Shell: 1.2mm Steel  
 Size: 5.5"x14"  
 Lug: MSL60S  
 Hoop: Triple Flange Hoop (6 hole)  
 Strainer/Butt: MCS70A/MCS70B  
 Snare Wire: MS16R10S  
 \*Tom bracket & MC69 single tom attachment are included.



**STEEL**

**DST1465**

Shell: 1.2mm Steel  
 Size: 6.5"x14"  
 Lug: MSL60S  
 Hoop: Steel Mighty Hoop (10 hole)  
 Strainer/Butt: MCS70A/MCS70B  
 Snare Wire: MS20R14S





5"x6"

**STS065M**

Shell: 1mm Steel  
Size: 5"x6"  
Lug: MSL60T  
Hoop: Triple Flange Hoop (4 hole)  
Snare Wire: Half-set Snare Wires  
\*Tom bracket & MC69 single tom attachment are included.



5"x8"

**STS085M**

Shell: 1mm Steel  
Size: 5"x8"  
Lug: MSL60T  
Hoop: Triple Flange Hoop (4 hole)  
Snare Wire: Half-set Snare Wires  
\*Tom bracket & MC69 single tom attachment are included.



5"x10"

**STS105M**

Shell: 1mm Steel  
Size: 5"x10"  
Lug: MSL60T  
Hoop: Triple Flange Hoop (6 hole)  
Snare Wire: Half-set Snare Wires  
\*Tom bracket & MC69 single tom attachment are included.



KENNY ARONOFF



CHARLIE BENANTE

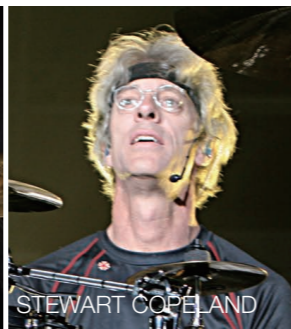

STEWART COPELAND



JOHN DOLMAYAN



PETER ERSKINE

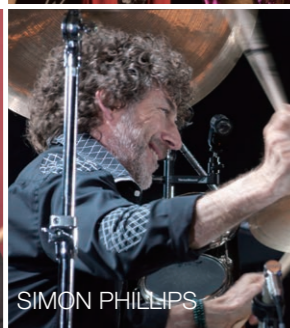

SIMON PHILLIPS



MIKE PORTNOY



JOHN TEMPESTA



LARS ULRICH

**KENNY ARONOFF**

**KA145N** MADE IN JAPAN

Trackmaster  
Shell: 1mm Brass  
Size: 5"x14"  
Lug: MSL35  
Hoop: Die-Cast Hoop (10 hole)  
Strainer/Butt: MUS80A/MUS80B  
Snare Wire: MS20SN14S



**KENNY ARONOFF**

**KA154** MADE IN JAPAN

Trackmaster Super Piccolo  
Shell: 1mm Brass  
Size: 4"x15"  
Lug: MSL-SCP (Nickel)  
Hoop: Brass Mighty Hoop (8 hole)  
Strainer/Butt: MCS70A/MUS80B (Nickel)  
Snare Wire: MS20SN15S



**KENNY ARONOFF**

**KA1465** MADE IN JAPAN

Trackmaster  
Shell: 1mm Brass  
Size: 6.5"x14"  
Lug: MSL35 (Nickel)  
Hoop: Brass Mighty Hoop (10 hole)  
Strainer/Butt: MUS80A/MUS80B (Nickel)  
Snare Wire: MS20SN14S



**CHARLIE BENANTE**

**CB1465** MADE IN JAPAN

Shell: 1.2mm Stainless Steel  
Size: 6.5"x14"  
Lug: MSL35BN  
Hoop: Die-Cast Hoop (10 hole)  
Strainer/Butt: MUS80ABN/MUS80BBN  
Snare Wire: MS20SN14S



**STEWART COPELAND**

**SC145** MADE IN JAPAN

Shell: 1.5mm Brass  
Size: 5"x14"  
Lug: MSL35  
Hoop: Die-Cast Hoop (10 hole Batter side)/Steel Mighty Hoop (10 hole Snare side)  
Strainer/Butt: MUS80A/MUS80B  
Snare Wire: MS20SN14S



**PETER ERSKINE**

**PE106M** MADE IN JAPAN NEW

Shell: 10mm 12pcs Stave Ash  
Size: 6"x10"  
Lug: MSL90S  
Hoop: Die-Cast Hoop (6 Hole)  
Strainer/Butt: MSL50A/MUS50B  
Snare Wire: MS20SN10S  
Super Resonant Mounting System Equipped



**SIMON PHILLIPS**

**SP1455H** MADE IN JAPAN

The Gladiator  
Shell: 1mm Bronze  
Size: 5.5"x14"  
Lug: MSL35H  
Hoop: Brass Mighty Hoop (10 hole, Brushed Nickel)  
Strainer/Butt: MUS80AH/MUS80BH  
Snare Wire: MS20S-S



**MIKE PORTNOY**

**MP125ST** MADE IN JAPAN

Shell: 1mm Steel (Hammered Matte Black)  
Size: 5"x12"  
Lug: MSL-SCT  
Hoop: Die-Cast Hoop (6 hole)  
Strainer/Butt: MCS100A (US. PAT.NO.6534698)/MCS70B  
Snare Wire: MS20SN12S



**MIKE PORTNOY**

**MP1455BU** MADE IN JAPAN

Shell: 8mm, 9ply Bubinga  
Size: 5.5"x14"  
Lug: MSL-SCT  
Hoop: Die-Cast Hoop (8 hole)  
Strainer/Butt: MCS100A/MCS70B  
Snare Wire: MS20SN14S



**LARS ULRICH**

**LU1465** MADE IN JAPAN

Shell: 3mm Diamond Plate Steel  
Size: 6.5"x14"  
Lug: MSL36  
Hoop: Die-Cast Hoop (10 hole)  
Strainer/Butt: MUS80A/MUS80B  
Snare Wire: MS20SN14S

**JOHN DOLMAYAN**

**JD146** MADE IN JAPAN

Shell: 5mm, 6ply Maple  
Size: 6"x14"  
Lug: Specially Designed Tube Lug  
Hoop: Die-Cast Hoop (10 hole)  
Strainer/Butt: MUS80ABN/MUS80BBN  
Snare Wire: MS20SN14C



**SIMON PHILLIPS**

**SP125H** MADE IN JAPAN

The Pageant  
Shell: 6mm, 7ply Figured Maple w/ 6mm Sound Focus Rings  
Size: 5"x12"  
Lug: MSL35H  
Hoop: Die-Cast Hoop (6 hole, Brushed Nickel)  
Strainer/Butt: MUS80AH/MUS80BH  
Snare Wire: MS20S-12S



**SIMON PHILLIPS**

**SP1465H** MADE IN JAPAN

The Monarch  
Shell: 6mm, 3ply Figured Maple/3ply Bubinga/2ply Maple w/ 6mm Sound Focus Rings  
Size: 6.5"x14"  
Lug: MSL-SCTH  
Hoop: Customized Brass Mighty Hoop (8 hole)  
Strainer/Butt: MUS80AH/MUS80BH  
Snare Wire: MS20S-S



**MIKE PORTNOY**

**MP1455ST** MADE IN JAPAN

Shell: 1mm Steel (Hammered Matte Black)  
Size: 5.5"x14"  
Lug: MSL-SCT  
Hoop: Die-Cast Hoop (8 hole)  
Strainer/Butt: MCS100A (US. PAT.NO.6534698)/MCS70B  
Snare Wire: MS20SN14S



**JOHN TEMPESTA**

**JT147** MADE IN JAPAN

Shell: 2mm Brass  
Size: 7"x14"  
Lug: MSL-SCTBN  
Hoop: Die-Cast Hoop (10 hole)  
Strainer/Butt: MUS80ABN/MUS80BBN  
Snare Wire: MS42R14S





# DRUM PEDALS

Our Iron Cobra pedals have long been praised for being smooth, reliable, and independently adjustable. Iron Cobra pedals are offered in the high end 900 series as well as the standard 600 and 200 models. Speed Cobra 910 and 310 drum pedals feature a longer footboard for a lighter, quicker feel. Our drum pedal range is designed to fit the needs of every drummer.

SPEED COBRA 910



## SINGLE

### HP910LN

- Long Footboard
- Recessed Setting (US.PAT.NO.8269089)
- Rolling Glide LiteSprocket
- Accu-Strike Cobra Beater
- Swivel Spring Tight (US.PAT.NO.9236038)
- Super Stabilizer Design
- Para-Clamp II Pro (US.PAT.NO.6011208)
- Super Spring
- Cobra Coil (US.PAT.NO.7408104)
- Oiles® Bearing Hinge (US.PAT.NO.6100460)
- Hinge Guard Block
- Speedo-Ring
- Vari-Pitch Beater Holder
- Hardshell Carrying Case



### HP910LWLN

-Left-Footed Twin Pedal

## TWIN

### HP910LWLN

- Long Footboard
- Recessed Setting
- Rolling Glide LiteSprocket
- Accu-Strike Cobra Beater
- Swivel Spring Tight
- Super Stabilizer Design
- Para-Clamp II Pro
- Super Spring
- Cobra Coil
- Oiles® Bearing Hinge
- Hinge Guard Block
- Speedo-Ring
- Vari-Pitch Beater Holder
- Hardshell Carrying Case

IRON COBRA 900



## SINGLE POWER GLIDE

### HP900PN

- Power Glide LiteSprocket
- Power-Strike Cobra Beater
- Swivel Spring Tight
- Super Stabilizer Design
- Para-Clamp II Pro
- Cobra Coil
- Oiles® Bearing Hinge
- Hinge Guard Block
- Speedo-Ring
- Vari-Pitch Beater Holder
- Hardshell Carrying Case



### HP900PWLN

-Left-Footed Twin Pedal

## TWIN POWER GLIDE

### HP900PWN

- Power Glide LiteSprocket
- Power-Strike Cobra Beater
- Swivel Spring Tight
- Super Stabilizer Design
- Para-Clamp II Pro
- Cobra Coil
- Oiles® Bearing Hinge
- Hinge Guard Block
- Speedo-Ring
- Vari-Pitch Beater Holder
- Hardshell Carrying Case

## SINGLE ROLLING GLIDE

### HP900RN

- Rolling Glide LiteSprocket
- Power-Strike Cobra Beater
- Swivel Spring Tight
- Super Stabilizer Design
- Para-Clamp II Pro
- Cobra Coil
- Oiles® Bearing Hinge
- Hinge Guard Block
- Speedo-Ring
- Vari-Pitch Beater Holder
- Hardshell Carrying Case



## TWIN ROLLING GLIDE

### HP900RWN

- Rolling Glide LiteSprocket
- Power-Strike Cobra Beater
- Swivel Spring Tight
- Super Stabilizer Design
- Para-Clamp II Pro
- Cobra Coil
- Oiles® Bearing Hinge
- Hinge Guard Block
- Speedo-Ring
- Vari-Pitch Beater Holder
- Hardshell Carrying Case

IRON COBRA 600



## SINGLE

### HP600D

- Duo Glide (US.PAT.NO.8748721)
- Double Chain Drive
- Speedo-Ring
- Para-Clamp
- Spring Tension Adjustment
- Beater Angle Adjustment
- Dual Sided Beater



## TWIN

### HP600DTW

- Duo Glide
- Double Chain Drive
- Speedo-Ring
- Para-Clamp
- Spring Tension Adjustment
- Beater Angle Adjustment
- Dual Sided Beater

SPEED COBRA 310



## SINGLE

### HP310L

- Long Footboard
- Recessed Setting
- Rolling Glide LiteSprocket
- Double Chain Drive
- Spring Tension Adjustment
- Beater Angle Adjustment
- Dual Sided Beater

IRON COBRA 200



## SINGLE

### HP200P

- Power Glide
- Spring Tension Adjustment
- Beater Angle Adjustment
- Dual Sided Beater

STANDARD PEDAL



## SINGLE

### HP30

- Power Glide
- Spring Tension Adjustment
- Beater Angle Adjustment
- Dual Sided Beater

COBRA CLUTCH/ TWIN PEDAL ATTACHMENT



## COBRA CLUTCH

### HH905XP

(US.PAT.NO.7135633)

A hi-hat control solution for double bass players! Instead of the loose, inexact, drop-clutch approach, the Cobra Clutch delivers a precise, fine-tuned degree of cymbal closure pressure, that's easily engaged and disengaged with a simple tap of the foot. \*The Cobra Clutch comes standard with a form-fitted hardshell carrying case.

## TWIN

### HP310LW

- Long Footboard
- Recessed Setting
- Rolling Glide LiteSprocket
- Double Chain Drive
- Spring Tension Adjustment
- Beater Angle Adjustment
- Dual Sided Beater



## TWIN

### HP200PTW

- Power Glide
- Spring Tension Adjustment
- Beater Angle Adjustment
- Dual Sided Beater



## ATTACHMENT

### TPA90

TWIN PEDAL ATTACHMENT

Specially designed attachment to connect Speed Cobra 910 and Iron Cobra 900 series pedals with Speed Cobra 910 and Iron Cobra 900 series Hi-hat stands.





# HI-HAT STANDS

In addition to bass drum pedals, we offer various hi-hat stands including our high end Iron Cobra & Speed Cobra models as well as our standard Stage Master models.

SPEED COBRA 910



## LEVER GLIDE

### HH915D NEW

- Spring Seat (US.PAT.NO.8604325)
- Quick-Set Hi-Hat Clutch (PAT.PENDING)
- Long Footboard
- 6-way Tension Adjustment
- Oiles® Bearing Hinge
- Spare-The-Rods Tension Rod Protector
- Non-Loosening Tension Rod (US.PAT.NO.6075192)
- Footboard Angle Adjustment
- Duo-Spike (US.PAT.NO.6031170)
- Tilt System
- Additional Short Rod Included

IRON COBRA 900



## LEVER GLIDE

### HH905D NEW

- Spring Seat
- Quick-Set Hi-Hat Clutch
- 6-way Tension Adjustment
- Oiles® Bearing Hinge
- Spare-The-Rods Tension Rod Protector
- Non-Loosening Tension Rod
- Footboard Angle Adjustment
- Duo-Spike
- Tilt System
- Additional Short Rod Included



## VELO GLIDE

### HH805D NEW

- Spring Seat
- Quick-Set Hi-Hat Clutch
- 6-way Tension Adjustment
- Oiles® Bearing Hinge
- Spare-The-Rods Tension Rod Protector
- Non-Loosening Tension Rod
- Footboard Angle Adjustment
- Duo-Spike
- Tilt System
- Additional Short Rod Included

SPEED COBRA 310



## SPEED COBRA 310

### HH315D NEW

- Dual Leg
- Security Clutch
- 6-way Tension Adjustment
- Swivel Foot
- Direct Pull Action
- Spare-The-Rods Tension Rod Protector
- Non-Loosening Tension Rod

IRON COBRA 600 / IRON COBRA 200



## IRON COBRA 600

### HH605

- Spring Seat
- Swing Lock Clutch
- 6-way Tension Adjustment
- Swivel Foot
- Direct Pull Action
- Spare-The-Rods Tension Rod Protector
- Non-Loosening Tension Rod
- Footboard Angle Adjustment (US.PAT.NO.6747200)



## IRON COBRA 200

### HH205

- 5-way Tension Adjustment
- Swivel Foot
- Direct Pull Action
- Non-Loosening Tension Rod
- Toe Guard
- Security Clutch

STAGE MASTER



## STAGE MASTER

### HH45W NEW

- Direct Pull Action
- Double Braced Legs
- Swivel Foot
- Non-Loosening Tension Rod
- Toe Guard
- Security Clutch



## STAGE MASTER

### HH45S NEW

- Direct Pull Action
- Single Braced Legs
- Swivel Foot
- Non-Loosening Tension Rod
- Toe Guard
- Security Clutch



# DRUM THRONES

Being comfortable on your drum set is one of the most important aspects of drumming, making the drum throne a vital yet often overlooked piece of equipment. Our ergonomic 1st Chair Drum Thrones have many original TAMA features to guarantee comfort, stability, and quick, easy setup.

1st CHAIR ROUND RIDER XL



## ROUND RIDER XL

### HT850BC NEW

- Round Rider XL "Cloth Top" Seat
- 15" Diameter, 130mm (5 1/8") Thick Round Seat
- HYDRAULIX
- Seat Lock (US.PAT.NO.6030045)
- Oversized Rubber Feet
- Foot Life
- Height Adjustment Range: 515mm - 695mm (21 1/4" - 27 3/8")



1st CHAIR ERGO-RIDER



## ERGO-RIDER

### HT750BC NEW

- Ergo-Rider "Cloth Top" Seat
- HYDRAULIX
- Foot Life
- Height Adjustment Range: 505mm - 685mm (19 7/8" - 27")



1st CHAIR WIDE RIDER



## WIDE RIDER

### HT530BC NEW

- Wide Rider "Cloth Top" Seat
- 1st Chair Height Adjustment
- Seat Lock
- Glide-Tite Grip Joint
- Rocklok
- Oversized Rubber Feet
- Foot Life
- Height Adjustment Range: 485mm - 640mm (19" - 25 3/16")



1st CHAIR ROUND RIDER



## ROUND RIDER

### HT430BC NEW

- Round Rider "Cloth Top" Seat
- 14" Diameter, 120mm (4 3/4") Thick Round Seat
- 1st Chair Height Adjustment
- Seat Link
- Rocklok
- Foot Life
- Height Adjustment Range: 485mm - 655mm (19" - 25 3/4")



STANDARD THRONES



## STANDARD

### HT65WN

- 13" Diameter, 90mm (3 1/2") Thick Round Seat
- Threaded Rod Height Adjustment
- Seat Link
- Double Braced Legs
- Adjustable Height Range: 490-660mm (19 15/16"-26")



## ROUND RIDER XL

### HT830B NEW

- Round Rider XL Seat
- 15" Diameter, 130mm (5 1/8") Thick Round Seat
- 1st Chair Height Adjustment
- Seat Lock
- Glide-Tite Grip Joint
- Rocklok
- Oversized Rubber Feet
- Foot Life
- Height Adjustment Range: 515mm - 670mm (21 1/4" - 27 3/8")



## ERGO-RIDER

### HT730B NEW

- Ergo-Rider Seat (US.PAT.NO.6672660)
- 1st Chair Height Adjustment
- Seat Lock
- Glide-Tite Grip Joint
- Rocklok
- Oversized Rubber Feet
- Foot Life
- Height Adjustment Range: 505mm - 660mm (19 7/8" - 26")



## WIDE RIDER

### HT530B NEW

- Wide Rider Seat
- 1st Chair Height Adjustment
- Seat Lock
- Glide-Tite Grip Joint
- Rocklok
- Oversized Rubber Feet
- Foot Life
- Height Adjustment Range: 485mm - 640mm (19" - 25 3/16")



## ROUND RIDER

### HT430B NEW

- Round Rider Seat
- 14" Diameter, 120mm (4 3/4") Thick Round Seat
- 1st Chair Height Adjustment
- Seat Link
- Rocklok
- Foot Life
- Height Adjustment Range: 485mm - 655mm (19" - 25 3/4")

## STANDARD

### HT65WNBR NEW

- 13" Diameter, 90mm (3 1/2") Thick Round Seat
- Threaded Rod Height Adjustment
- Seat Link
- Double Braced Legs
- Adjustable Height Range: 490-660mm (19 15/16"-26")



## ROUND RIDER XL

### HT830R NEW

- Round Rider XL Seat
- 15" Diameter, 130mm (5 1/8") Thick Round Seat
- 1st Chair Height Adjustment
- Seat Lock
- Glide-Tite Grip Joint
- Rocklok
- Oversized Rubber Feet
- Foot Life
- Height Adjustment Range: 515mm - 670mm (21 1/4" - 27 3/8")

## ERGO-RIDER

### HT741B NEW

- Ergo-Rider Seat
- 1st Chair Height Adjustment
- Seat Lock
- Backrest (US.PAT.NO.6193315)
- Glide-Tite Grip Joint
- Rocklok
- Oversized Rubber Feet
- Foot Life
- Height Adjustment Range: 515mm - 665mm (20 1/4" - 26 3/16")

## STANDARD

### HT130

- 13" Diameter, 90mm (3 1/2") Thick Round Seat
- Double Braced Legs
- Adjustable Height Range: 445mm - 620mm (17 1/2" - 24 7/16")



# SNARE STANDS

Our STAR snare stand has several unique features which provide the ultimate solution for a flexible and stable snare drum setup. Our Roadpro stands now have greater stability, in addition to Quick-Set universal tilters.

TAMA STAR



## TAMA STAR

### HS100W

- For 12" to 15" Diameter Snare Drums
- 28.6mm Diameter Base Section Tubing
- Cradle-Hold Snare Basket (US.PAT.NO.9099061)
- Glide-Tite Grip Joint (PAT.PENDING)
- True-Sound Insulation Mute
- Oversized Rubber Feet with Retractable Spike (US.PAT.NO.6031170)
- Extra Heavy Double Braced Legs
- Height Adjustment Range: 390mm - 600mm (15 3/8" - 23 5/8")

ROADPRO



## ROADPRO

### HS800W

- For 12" to 15" Diameter Snare Drums
- 28.6mm Diameter Base Section Tubing
- Omni-Ball Tilter
- Swiveling Basket
- Glide-Tite Grip Joint
- Double Braced Legs
- Adjustable Height Range: 495mm - 665mm (19 1/2" - 26 3/8")

## ROADPRO

### HS80W

- For 12" to 15" Diameter Snare Drums
- 28.6mm Diameter Base Section Tubing
- Quick-Set Tilter (US.PAT.NO.7385127)
- Swiveling Basket (US.PAT.NO.6384308)
- Glide-Tite Grip Joint
- Double Braced Legs
- Adjustable Height Range: 495mm - 640mm (19 1/2" - 25 3/16")

60 SERIES



## ROADPRO

### HS80PW

- For 10" to 12" Diameter Snare Drums
- 28.6mm Diameter Base Section Tubing
- Quick-Set Tilter
- Swiveling Basket
- Glide-Tite Grip Joint
- Double Braced Legs
- Adjustable Height Range: 495mm - 610mm (19 1/2" - 24")

## ROADPRO

### HS80LOW

- For 12" to 15" Diameter Snare Drums
- 28.6mm Diameter Base Section Tubing
- Low Position Setting Basket
- Quick-Set Tilter
- Glide-Tite Grip Joint
- Double Braced Legs
- Adjustable Height Range: 385mm - 530mm (15 3/16" - 20 7/8")

STAGE MASTER



## STAGE MASTER

### HS40W NEW

- For 12" to 15" Diameter Snare Drums
- 25.4mm Diameter Base Section Tubing
- Universal Gearless Tilter
- Swiveling Basket
- Double Braced Legs
- Adjustable Height Range: 470mm-630mm (18 1/2" - 24 13/16")

## STAGE MASTER

### HS40S NEW

- For 12" to 15" Diameter Snare Drums
- 25.4mm Diameter Base Section Tubing
- Universal Gearless Tilter
- Swiveling Basket
- Single Braced Legs
- Adjustable Height Range: 470mm-630mm (18 1/2" - 24 13/16")

## STAGE MASTER

### HS40LOW NEW

- For 12" to 15" Diameter Snare Drums
- 25.4mm Diameter Base Section Tubing
- Universal Gearless Tilter
- Double Braced Legs
- Adjustable Height Range: 370mm-530mm (14 9/16" - 20 7/8")

# CYMBAL STANDS

The TAMA STAR Hardware cymbal stand is incredibly flexible with several groundbreaking adjustment features. The Roadpro cymbal stands benefit from greater stability, and include the same great Quick-Set Tilter and Quick-Set Cymbal Mates.

TAMA STAR



## TAMA STAR

### HC103BW

- 28.6mm Diameter Base Section Tubing
- Orbital Quick-Tite Cymbal Tilter
- Orbital Quick-Tite Boom Tilter
- Glide-Tite Grip Joint
- True-Sound Insulation Mute
- Ring-True Cymbal Felt
- Quick-Set Cymbal Mate (US.PAT.NO.7629526)
- Oversized Rubber Feet
- Extra Heavy Double Braced Legs
- Boom Arm Length: 450mm (17 3/4")

ROADPRO



## ROADPRO

### HC84BW

- 28.6mm Diameter Base Section Tubing
- Quick-Set Tilter (US.PAT.NO.7385127)
- Quick-Set Cymbal Mate
- Boom/Straight Convertible Tilter
- Glide-Tite Grip Joint
- Double Braced Legs
- Detachable Counter Weight
- Boom Arm Length (incl. Counter Weight): 688mm (27 3/32")

60 SERIES



## ROADPRO LIGHT

### HC83BLS

- 25% Light Weight
- \*Compared with Roadpro double braced leg model
- 25.4mm Diameter Base Section Tubing
- Quick-Set Tilter
- Quick-Set Cymbal Mate
- Boom/Straight Convertible Tilter
- Glide-Tite Grip Joint
- Single Braced Legs
- Boom Arm Length: 400mm (15 3/4")

STAGE MASTER



## STAGE MASTER

### HC43BW NEW

- 25.4mm Diameter Base Section Tubing
- Quick-Set Cymbal Mate
- Fine Gear Tilter
- Boom/Straight Convertible Tilter
- Double Braced Legs
- Boom Arm Length: 400mm (15 3/4")



ROADPRO



## ROADPRO

### HC83BW

- 28.6mm Diameter Base Section Tubing
- Quick-Set Tilter
- Quick-Set Cymbal Mate
- Boom/Straight Convertible Tilter
- Glide-Tite Grip Joint
- Double Braced Legs
- Boom Arm Length: 450mm (17 3/4")

60 SERIES



## ROADPRO LIGHT

### HC82LS

- 25% Light Weight
- \*Compared with Roadpro double braced leg model
- 25.4mm Diameter Base Section Tubing
- Quick-Set Tilter
- Quick-Set Cymbal Mate
- Glide-Tite Grip Joint
- Single Braced Legs

60 SERIES



## 60 SERIES

### HC62W

- 25.4mm Diameter Base Section Tubing
- Quick-Set Tilter
- Double Braced Legs



STAGE MASTER



**STAGE MASTER**

**HC42W** NEW

- 25.4mm Diameter Base Section Tubing
- Quick-Set Cymbal Mate
- Fine Gear Tilt
- Double Braced Legs



**STAGE MASTER**

**HC42S** NEW

- 25.4mm Diameter Base Section Tubing
- Quick-Set Cymbal Mate
- Fine Gear Tilt
- Single Braced Legs

THE CLASSIC STAND



**THE CLASSIC STAND**

**HC52F**

- 19.1mm Diameter Base Section Tubing
- Flat Base Leg Design
- 9mm Diameter Solid Upper Portion
- Light Weight (1.48kg)
- Compact Folding Design (580mm 22 27/32")
- Fine Gear Tilt



ROADPRO



**DOUBLE TOM**

**HTW849W**

- 28.6mm Diameter Base Section Tubing
- Omni-Ball Tom Angle Adjustment
- Glide-Tite Grip Joint
- Double Braced Legs
- Low Profile Tetrapod

STAGE MASTER



**DOUBLE TOM**

**HTW49W** NEW

- 25.4mm Diameter Base Section Tubing
- Omni-Ball Tom Angle Adjustment
- Double Braced Legs

DOUBLE TOM HOLDERS



**DOUBLE**

**MTH1000**  
(US.PAT.NO.9087498)

- 25.4mm Diameter Base Section Tubing
- Swivel-Wing Tom Holder

**MTH1000BN**  
(Black Nickel)



**DOUBLE**

**MTH909**  
(US.PAT.NO.7381876)

- 25.4mm Diameter Base Section Tubing
- Sliding Tom Adjustment

**MTH909BN**  
(Black Nickel)

**TOM STANDS & TOM HOLDERS**

TAMA's tom stands and tom holders feature our original Omni-Ball system which allows each tom to be held securely in place. You can position the drum at virtually any angle simply by loosening one T-nut.

TAMA STAR



**COMBINATION**

**HTC107W**

- 28.6mm Diameter Base Section Tubing
- Swivel-Wing Tom Holder (US.PAT.NO.9087498)
- Orbital Quick-Tite Cymbal Tilter
- Orbital Quick-Tite Boom Tilter
- Glide-Tite Grip Joint
- True-Sound Insulation Mute
- Ring-True Cymbal Felt
- Extra Heavy Double Braced Legs
- Boom Arm Length: 300mm (11 3/4")



**DOUBLE TOM**

**HTW109W**

- 28.6mm Diameter Base Section Tubing
- Swivel-Wing Tom Holder
- Stilt System
- Glide-Tite Grip Joint
- Extra Heavy Double Braced Legs



**SINGLE TOM**

**HTS108W**

- For up to 10" Depth Tom Tom
- 28.6mm Diameter Base Section Tubing
- Glide-Tite Grip Joint
- True-Sound Insulation Mute
- Extra Heavy Double Braced Legs
- Oversized Rubber Feet with Retractable Spike

SINGLE TOM HOLDERS



**DOUBLE**

**MTH905N**

- 25.4mm Diameter Tubing
- Sliding Tom Adjustment



**DOUBLE**

**MTH600**

- 25.4mm Diameter Tubing

**MTH600BN** NEW  
(Black Nickel)

ROADPRO



**COMBINATION**

**HTC807W**

- 28.6mm Diameter Base Section Tubing
- Omni-Ball Tom Angle Adjustment / Movable Tom Positioning
- Quick-Set Tilter
- Quick-Set Cymbal Mate
- Glide-Tite Grip Joint
- Double Braced Legs
- Boom Arm Length: 300mm (11 3/4")



**COMBINATION**

**HTC87W**

- 28.6mm Diameter Base Section Tubing
- Omni-Ball Tom Angle Adjustment
- Quick-Set Tilter
- Quick-Set Cymbal Mate
- Glide-Tite Grip Joint
- Double Braced Legs
- Boom Arm Length: 300mm (11 3/4")



**DOUBLE TOM**

**HTW839W**

- 28.6mm Diameter Base Section Tubing
- Omni-Ball Tom Angle Adjustment
- Stilt System
- Glide-Tite Grip Joint
- Double Braced Legs



**SINGLE**

**MTH1000S**

- 25.4mm Diameter Base Section Tubing
- Swivel-Wing Tom Holder

**MTH1000SBN**  
(Black Nickel)



**SINGLE**

**MTH900BS**

- 25.4mm Diameter Base Section Tubing

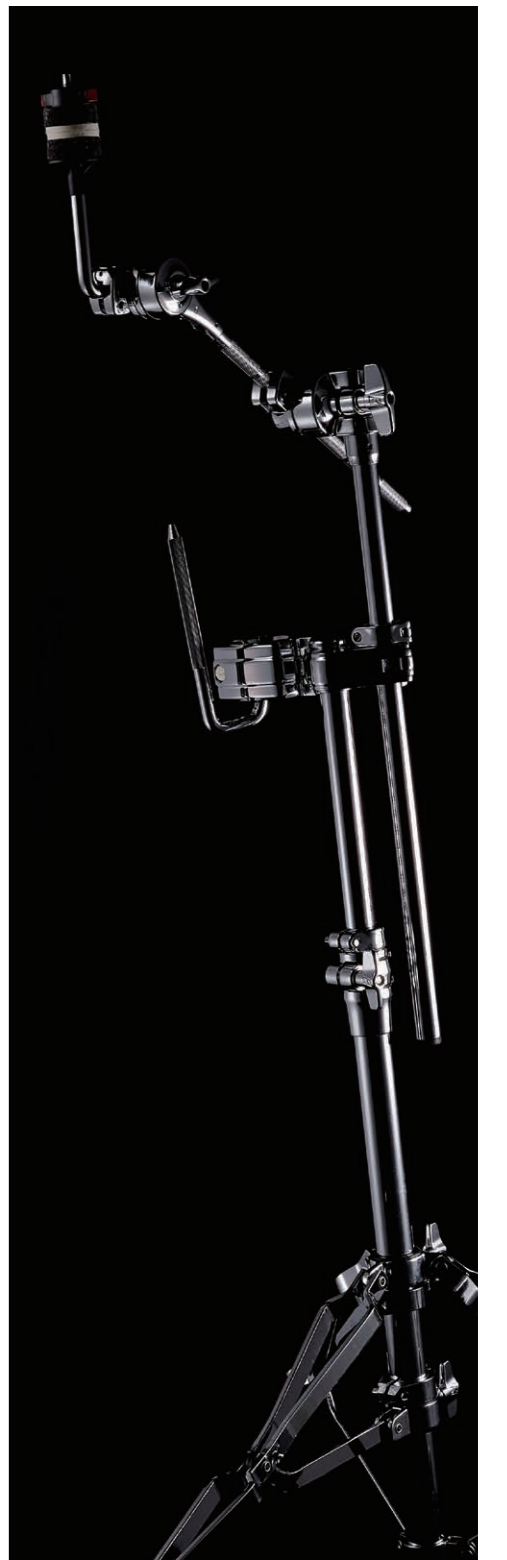

**SINGLE**

**MTH900BM**

- 25.4mm Diameter Tubing



# HARDWARE KITS

We offer various hardware kit packages to complement any drum set.

HARDWARE KITS

## IRON COBRA 900

**HG5WN** NEW

- HS800W Roadpro Snare Stand
- HC83BW Roadpro Boom Cymbal Stands (x 2)
- HH905D Iron Cobra Hi-hat Stand
- HP900PN Iron Cobra Power Glide Single Pedal



## IRON COBRA 200

**HB5W**

- HS60W Snare Stand
- HC63BW Boom Cymbal Stands (x 2)
- HH205 Iron Cobra Hi-hat Stand
- HP200P Iron Cobra Single Pedal



## IRON COBRA 600

**HV5WN**

- HS80W Roadpro Snare Stand
- HC83BW Roadpro Boom Cymbal Stands (x 2)
- HH605 Iron Cobra Hi-hat Stand
- HP600D Iron Cobra Duo Glide Single Pedal



## STAGE MASTER

**MM5WN** NEW

- HS40W Stage Master Snare Drum Stand
- HC43BW Stage Master Boom Cymbal Stands (x 2)
- HH45W Stage Master Hi-Hat Stand
- HP200P Iron Cobra Single Pedal



# POWER TOWER SYSTEM

TAMA's Power Tower System allows you to maintain the same precise set-up time after time. It utilizes 38.1mm stainless round pipes which allow for drums and hardware to be set-up at any angle quickly and easily.



## BASIC UNIT

### PMD1100M



Description	Q'ty
φ38.1 x 1100mm Curved Pipe (SP1100C)	1
φ38.1 x 850mm Straight pipe w/φ19.1mm Joint (SP850SJ)	2
40mm x 20mm x 450mm Square pipe (SP450L)	2
Leg Joint Bracket (J14T)	2
Rubber foot (TC)	4
Cross Joint Bracket (J30TS)	2
Multi Holder (J34T)	2
Memory Lock (A13S)	4

## ADDITIONAL UNIT

### PMD1100A



Description	Q'ty
φ38.1 x 1100mm Curved Pipe (SP1100C)	1
φ38.1 x 850mm Straight pipe w/φ19.1mm Joint (SP850SJ)	1
40mm x 20mm x 450mm Square pipe (SP450L)	1
Leg Joint Bracket (J14T)	1
Rubber foot (TC)	2
Cross Joint Bracket (J30TS)	2
Multi Holder (J34T)	1
Memory Lock (A13S)	3

## ADDITIONAL UNIT

### PMD900A



Description	Q'ty
φ38.1 x 900mm Curved Pipe (SP900C)	1
φ38.1 x 850mm Straight pipe w/φ19.1mm Joint (SP850SJ)	1
40mm x 20mm x 450mm Square pipe (SP450L)	1
Leg Joint Bracket (J14T)	1
Rubber foot (TC)	2
Cross Joint Bracket (J30TS)	2
Multi Holder (J34T)	1
Memory Lock (A13S)	3

## CROSS JOINT BRACKET

### J30TS

90 degree perpendicular pipe clamp that allows horizontal and vertical pipes to be set at an equal height.



## MULTI HOLDER

### J34T

Rack mount for L-rods, tom or cymbal holders. Fits pipes from 10.5mm to 28.6mm in diameter.



## MEMORY LOCK

### A13S

Memory clamp designed specifically for the Power Tower System.



## SINGLE TOM HOLDER

### MTH900BS

A single tom holder with 25.4mm diameter base tube.





# CLAMPS AND ATTACHMENTS

Back in the 1970's TAMA's original introduction of the multi-clamp was a real revolution in the complex instrument we know as the drum kit. Today, multi-clamps are standard equipment in drums of all brands.

## UNIVERSAL CLAMP

### MC66

One side can hold pipes with diameters from 15.9mm to 28.6mm, while the other side is a ratchet holder that can hold a rod from 9mm to 12mm in diameter at various angles. An excellent clamp for adding an array of new set-up possibilities.



## UNIVERSAL CLAMP

### MC67

The heavier duty version of the MC66. One side holds pipes with diameters from 15.9mm to 28.6mm, while the other side is a ratchet holder that can hold a 12mm to 25.4mm diameter rod or pipe at various angles.



## MULTI-CLAMP

### MC61 (US.PAT.NO.6096956)

A basic clamp for connecting stands with pipes from 15.9mm to 28.6mm in diameter with any attachment having a 19.1mm diameter pipe.

## MULTI-CLAMP

### MC62

A double multi-clamp for connecting two pipes from 15.9mm to 28.6mm in diameter. Both sides feature the FastClamp Easy Set-Up System.



## COMPACT CLAMP

### MC5 (US.PAT.NO.6093878)

A clamp for connecting parts with diameters of between 9mm to 12mm together. By combining a boom arm (MCB30EN, MCB45EN) and an L-rod (LLT, LCB, LCYE), this clamp can be used to attach a variety of parts onto a simple boom arm.



## COMPACT CLAMP

### MC7

Same function as the MC5, but with even greater flexibility. The ratchet holder section can hold any diameter tube from 12mm to 25.4mm.

## CLOSED HI-HAT

### MXA53 (US.PAT.NO.6177621)

Simply designed closed hi-hat attachment that allows for two different settings by turning a lever. Attachable to stands from 15.9mm to 28.6mm in diameter. Great for double bass or double pedal players. And, you can also set up half open hi-hat cymbals by adjusting the spring.



## CLOSED HI-HAT

### MXA73N NEW

This closed hi-hat attachment is ideal for double bass playing. The tension adjustment knob makes it possible to finely adjust the degree of opening of the hi-hat cymbals. In addition, the angle of the bottom cymbal is also adjustable, which allows for subtle adjustment of the sound of a closed or half-open hi-hat by changing how air escapes with each hit.



## L-ROD FOR TOM

### LLT

L-rod for mounting toms (10.5mm diameter).

## L-ROD FOR COWBELL

### LCB

L-rod for mounting different hand percussion instruments and accessories. The 9mm diameter rod fits most popular percussion instruments designed for attachment to a 3/8" rod.



## L-ROD FOR RW200

### LRW

Specially designed rod for mounting the Rhythm Watch to your kit in combination with the recommended MC66 multi-clamp.



## L-ROD FOR CYMBAL

### LCYE

L-rod for mounting lightweight cymbals.

## CYMBAL STACKER

### CSA15

The CSA15 is a straight-forward cymbal stacker useful for adding small cymbals to your setup using the M8 threaded cymbal rod.



## CYMBAL STACKER

### CSA25

The CSA25 allows positioning of a small cymbal on the M8 threaded cymbal rod, as well as independent angle adjustment.

## RATCHET ARM

### MRB30

The MRB30 features a 12mm rod for lighter duty usage. 300mm (11 3/4") length



## RATCHET ARM

### MTA30

The MTA30 ratchet arm features a 19.1mm pipe. 300mm (11 3/4") length



## RATCHET ARM

### MTA45

The MTA45 ratchet arm features a 19.1mm pipe. 450mm (17 3/4") length

## BOOM ARM

### MCB30EN

300mm (11 3/4") length  
The MCB30EN can be used in combination with a ratchet arm or the MC66 universal clamp.



## BOOM ARM

### MCB45EN

450mm (17 3/4") length  
The MCB45EN can be used in combination with a ratchet arm or the MC66 universal clamp.



## CYMBAL HOLDER

### CA30EN

300mm (11 3/4") length  
This cymbal holder with a pipe diameter of 19.1mm can be attached to stands using either the MC61 or MC62 multi-clamp. The CA30EN is a professional-grade model equipped with a conversion function that allows the boom arm to be stored in the stand pipe and also includes the Quick-Set Tilter for convenient and easy set-up.

## CYMBAL HOLDER

### CA45EN

450mm (17 3/4") length  
This cymbal holder with a pipe diameter of 19.1mm can be attached to stands using either the MC61 or MC62 multi-clamp. The CA45EN is a professional-grade model equipped with a conversion function that allows the boom arm to be stored in the stand pipe and also includes the Quick-Set Tilter for convenient and easy set-up.



## CYMBAL ATTACHMENT

### CCA30

300mm (11 3/4") length boom arm and tube

The assortment of boom cymbal holder and MC61 multi-clamp. By connecting to stands from 15.9mm to 28.6mm in diameter, you can add any cymbal easily.



## CYMBAL ATTACHMENT

### MCA53

The MCA53 is a simplified attachment based on the functionality of the MCA63EN. Add cymbals by securing this attachment to stands from 15.9mm to 28.6mm in diameter.

## CYMBAL ATTACHMENT

### MCA63EN

Combines the MC66 universal clamp and the MCB30EN boom arm. Works perfectly for adding cymbals and accessories.



## CYMBAL ATTACHMENT

### CYA5E

Combines the MC5 compact clamp with the LCYE L-rod for mounting one cymbal to one boom arm. Can be clamped to rods from 9mm to 12mm in diameter or to the L-rod of a tom holder.



## TOM ATTACHMENT

### MC69 (US.PAT.NO.8742240)

Clamping this attachment on a 15.9mm to 28.6mm diameter pipe allows for direct set-up of toms. Even with a compact construction, the inclusion of the Omni-ball feature at the angle adjustment point lets you adjust toms to any angle.

## TOM ADAPTER

### MTH900AS

This adapter allows you to add single toms to stands using the flexibility and speed of TAMA's Omni-Ball/L-rod combination.



## COWBELL ATTACHMENT

### CBA5

Compact attachment for mounting hand percussion such as cowbells or tambourines. Combines the MC5 compact clamp and the LCB L-rod to provide set-up flexibility. The 3/8" L-rod fits most popular percussion instruments and accessories.



## COWBELL ATTACHMENT

### CBA56

Combines the universal clamp with the LCB L-rod for most popular percussion instruments and accessories. Can be clamped to pipes from 15.9mm to 28.6mm in diameter.

## COWBELL ATTACHMENT

### CBH20

This simple attachment allows cowbells to be mounted on the bass drum. The length and angle of the L-rod can be easily changed for optimum positioning.



## HI-HAT ATTACHMENT

### MHA623

Connects the hi-hat to the hoop of a double bass drum so the hi-hat legs can be closed. An improved design featuring the Para-Clamp mechanism from the Iron Cobra pedal makes attachment even easier and more secure.



# MICROPHONE STANDS

The heavy-duty microphone stands are the result of over a quarter century of our experience in creating innovative, professional drum and performance hardware.

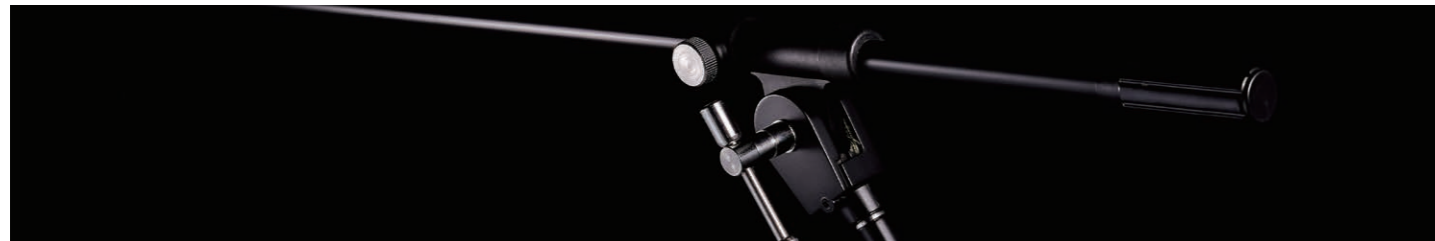

## TELESCOPING BOOM STAND

**MS736BK** NEW  
**IRON WORKS STUDIO**  
 Black Finish  
 -Vice-Grip Boom Tilter  
 -Iron-Core Legs with Vibration-Isolating Rubber Feet  
 -Iron-Core Boom Arm  
 -Detachable Boom Arm

Height : 975-1650mm (38 3/8"-64 15/16")  
 Boom arm : 505-850mm (19 7/8"-33 7/16")  
 Weight : 5.4kg



## LOW PROFILE TELESCOPING BOOM STAND

**MS736LBK** NEW  
**IRON WORKS STUDIO**  
 Black Finish  
 -Vice-Grip Boom Tilter  
 -Iron-Core Legs with Vibration-Isolating Rubber Feet  
 -Iron-Core Boom Arm  
 -Detachable Boom Arm

Height : 440-605mm (17 5/16"-23 13/16")  
 Boom arm : 505-850mm (19 7/8"-33 7/16")  
 Weight : 4.7kg



## ROUND BASE EXTRA LOW PROFILE TELESCOPING BOOM STAND

**MS736RELBK** NEW  
**IRON WORKS STUDIO**  
 Black Finish  
 -Vice-Grip Boom Tilter  
 -Iron-Core Boom Arm  
 -Detachable Boom Arm  
 -Heavy Round Cast Base

Height : 280mm (11 1/32")  
 Boom arm : 505-850mm (19 7/8"-33 7/16")  
 Weight : 7.7kg



## TELESCOPING BOOM STAND

**MS436BK** NEW  
**IRON WORKS TOUR**  
 Black Finish  
 -Cast Grip Boom Tilter  
 -Die-Cast Locking Thumb Nut  
 -Sure-Cast Adjustment Collar  
 -Detachable Boom Arm

Height : 985-1660mm (38 3/4"-65 3/8")  
 Boom arm : 505-845mm (19 7/8"-33 1/4")  
 Weight : 3.9kg



## LOW PROFILE TELESCOPING BOOM STAND

**MS436LBK** NEW  
**IRON WORKS TOUR**  
 Black Finish  
 -Cast Grip Boom Tilter  
 -Die-Cast Locking Thumb Nut  
 -Sure-Cast Adjustment Collar  
 -Detachable Boom Arm

Height : 440-605mm (17 5/16"-23 13/16")  
 Boom arm : 505-845mm (19 7/8"-33 1/4")  
 Weight : 3.1kg



## BOOM STAND

**MS205**  
 Chrome Finish  
 -Cast Grip Boom Tilter

Height : 960-1600mm (38"-63")  
 Boom arm : 830mm (32 11/16")  
 Weight : 3.2kg



## BOOM STAND

**MS205BK**  
 Black Finish  
 -Cast Grip Boom Tilter

Height : 960-1600mm (38"-63")  
 Boom arm : 830mm (32 11/16")  
 Weight : 3.2kg



## STRAIGHT STAND

**MS200**  
 Chrome Finish

Height : 910-1550mm (36"-61")  
 Weight : 2.4kg



## STRAIGHT STAND

**MS200BK**  
 Black Finish

Height : 910-1550mm (36"-61")  
 Weight : 2.4kg



## STRAIGHT "ONE-HAND" STAND

**MS200FS**  
 Chrome Finish  
 -One-hand Height Adjustment

Height : 920-1530mm (36 1/4"-60 1/4")  
 Weight : 2.6kg



## ROUND BASE STAND

**MS200D**  
 Chrome Finish  
 -Cast Round Base with T-Bolt Pipe Fixing Devise

Height : 895-1510mm (35 1/4"-59 7/16")  
 Weight : 3.8kg



## ROUND BASE STAND

**MS200DBK**  
 Black Finish  
 -Cast Round Base with T-Bolt Pipe Fixing Devise

Height : 895-1510mm (35 1/4"-59 7/16")  
 Weight : 3.8kg



## SHORT BOOM STAND

**MS205ST**  
 Chrome Finish  
 - Cast Grip Boom Tilter

Height : 430-560mm (16 15/16"-22")  
 Boom arm : 510mm (20")  
 Weight : 2.3kg



## SHORT BOOM STAND

**MS205STBK**  
 Black Finish  
 - Cast Grip Boom Tilter

Height : 430-560mm (16 15/16"-22")  
 Boom arm : 510mm (20")  
 Weight : 2.3kg



## TABLE TOP STAND

**MS20**  
 Silver Finish

Height : 220-370mm (8 21/32"-14 9/16")  
 Weight : 1.1kg  
 Aluminum pipe that prevents scattered reflection.



## BOOM ARMS

**MS736BB** NEW  
 Vice-Grip Boom Tilter with Iron-Core Telescoping Boom Arm



## BOOM ARMS

**MS436BB** NEW  
 Cast-Grip Boom Tilter with Iron-Core Telescoping Boom Arm



## CORD CLIP

**CC5** NEW  
 For 15.9 mm (5/8") diameter tube.

**CC7** NEW  
 For 22.2 mm (7/8") diameter tube.  
 Unique durable and anti-drop design.



## DIE-CAST LOCKING THUMB NUT

**DTLN3** NEW  
 (For 3/8" connector)  
 Not only does the thumb nut's larger, sure-grip design allow greater leverage for faster, easier set-up and breakdown, its high quality zinc threads and walls are built to handle pressure for years to come.



## RUBBER FOOT

**756-RF** NEW  
 TAMA's extra thick rubber foot covers "float" the stand, isolating the microphone from floor vibrations. (for 19.1mm diameter leg)







## GONG BASS DRUM

**BG20R**  
14"x20" Starclassic Bubinga Gong Bass

**HGS800**  
Gong Bass Stand

An early TAMA original, the Gong Bass Drum uses a 22" head mounted on a 20" shell with no bottom head. This design produces a sound with excellent sustain that's close in character to a concert tympani. The Gong Bass Drum is available with 8mm thick Starclassic Bubinga shell. It is only available with chrome shell hardware.

The silver finish aluminum stable stand offers easy yet secure positioning thanks to TAMA's Power Tower stand components.

\*Gong Bass Drum is available in Piano Black (PBK) finish only.



BG20R + HGS800

## STEEL MINI-TYMP

**MT68ST/MT810ST**  
MT68ST 4"x6"+4"x8"  
MT810ST 4"x8"+4"x10"

Another affordable way to add new sonic color to your kit: TAMA's Steel Mini-Tymp produce a clear, sharp, percussive "crack" that gives drummers a new way to add accent to their playing, no matter what style of music. Steel Mini-Tymp are available in two models and come with an L-rod (LLT) and a multi-clamp (MC66).



MT68ST

MT810ST

## JINGLE RING

**TJR7**

The Jingle Ring is a slim tambourine that can be mounted on a hi-hat stand or as a separate item. It features 9 pairs of nickel jingles that produce a bright, clear, tambourine sound. Its eyebolt style clamp secures it firmly in place for playing, and allows mounting of the Jingle Ring to the hi-hat rod or the 8mm diameter rod of a boom arm.



## SONIC COWBELLS

**TSC4/TSC6**

TSC4 4" Cowbell  
TSC6 6" Cowbell

Our steel Sonic Cowbells are offered in two different models of varying tones. It features an eyebolt style clamp to prevent slippage while playing.



TSC4

TSC6

## OCTOBANS

**7850N2H/2L/4H/4L**

One of TAMA's first original instruments, TAMA Octobans have been played by progressive players from Simon Phillips to Stewart Copeland to Mike Portnoy. The pitch of Octobans changes with the shell length instead of the shell diameter. The 6" diameter shells can be tuned melodically and are available in low- and high-pitch sets.

Octobans	
Model No.	Depth
OCT280N	280mm (11")
OCT301N	301mm (11 3/4")
OCT343N	343mm (13 1/2")
OCT390N	390mm (15 1/2")
OCT443N	443mm (17 1/2")
OCT472N	472mm (18 1/2")
OCT536N	536mm (21")
OCT600N	600mm (23 1/2")

### •Octobans Set

- 7850N2H 2pc High-pitch set w/HOW29WN stand
- 7850N2L 2pc Low-pitch set w/HOW29WN stand
- 7850N4H 4pc High-pitch set w/HOW49WN stand
- 7850N4L 4pc Low-pitch set w/HOW49WN stand



7850N2H

7850N2L

7850N4H

7850N4L

## OCTOBAN STANDS

**HOW49WN/HOW29WN**

HOW49WN for 4pcs octobans  
HOW29WN for 2pcs octobans



HOW49WN

HOW29WN



## PRACTICE PAD

**TMP8S**



This practice pad is an actual 4" x 8" inch drum with a mesh head. It has a half cut snare wire facing the backside of the mesh head from inside the drum. The knurled knob on the side of the shell lets you adjust the snare tension from tight to loose and off. You can also adjust the tension of the mesh as on a conventional drum.

## PRACTICE PAD

**TSP10** NEW



TAMA's 10" practice pad is a single sided rubber pad. The rubber portion is wrapped around a wooden board for a natural, bouncy feel. Slightly thicker soft urethane material on the reverse side helps absorb impact and reduce volume.

## PRACTICE PAD

**TSP6**



The special urethane foam on this pad provides a nice bouncy feel for more enjoyable and more productive practice. The six-inch diameter size also makes it easily portable.

## PRACTICE PAD STAND

**HS40TP** NEW

The HS40TP training pad stand can hold pads between 6 and 10 inch diameters. The rubber grips of the basket can also be reversed for holding smaller pads more securely. An extension pipe is included for when practicing standing up is desired.



HS40TP + TSP10

\*Height adjustment range (measured from the top surface of a 10 inch training pad to the floor):  
w/o extension pipe: 505mm - 650mm (19 7/8" - 25 1/2")  
w/ extension pipe: 770 - 920mm (30 3/8" - 36 1/4")

## MESH HEADS



Individual		Set
for Tom Toms	for Bass Drums	Model No. Content
MH8T (8")	MH18B (18")	SPP518C 18" BD, 14" FT, 10" & 12" TT, 13" SD, 14" HH, 14" or 16" CYM
MH10T (10")	MH22B (22")	
MH12T (12")	for Cymbals	SPP522C 22" BD, 16" FT, 12" & 13" TT, 14" SD, 14" HH, 14" or 16" CYM, 18" or 20" CYM
MH13T (13")		
MH14T (14")	CM1416 (14" or 16" CYM)	SPP522KC 22" BD, 16" FT, 10" & 12" TT, 14" SD, 14" HH, 14" or 16" CYM, 18" or 20" CYM
MH16T (16")	CM1820 (18" or 20" CYM)	

## SILENT TIPS

**TCP20** NEW

Silent practice with your own sticks... any time, anywhere.





# BAGS

TAMA's heavy duty bags protect your drums from damage during transportation.

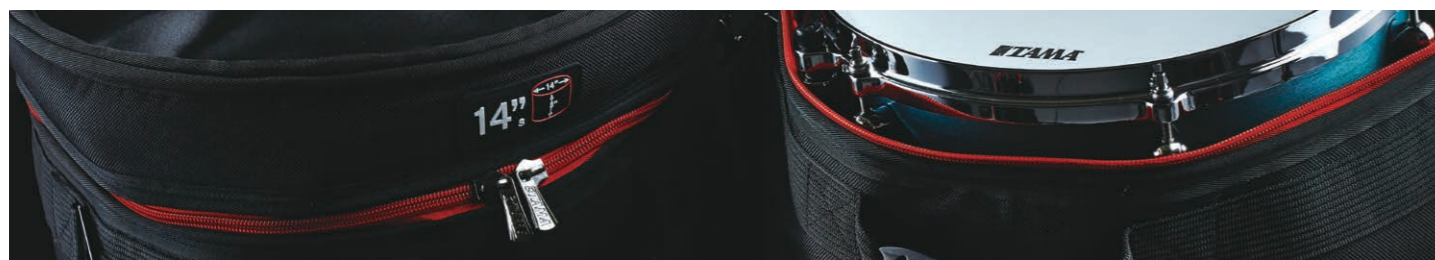

## POWERPAD Bag -Tom Tom-

### PBT12

9"x12" Tom Tom

- PBT8 (7" x 8")
- PBT10 (8" x 10")
- PBT12 (9" x 12")
- PBT13 (10" x 13")
- PBT14 (11" x 14")



## POWERPAD Bag -Floor Tom-

### PBF16

16"x16" Floor Tom

- PBF14 (14" x 14")
- PBF16 (16" x 16")
- PBB18 (16" x 18")



## POWERPAD Bag -Bass Drum-

### PBB22

18"x22" Bass Drum

- PBB18 (16" x 18")
- PBB20 (18" x 20")
- PBB22 (18" x 22")
- PBB22X (20" x 22")
- PBB24 (18" x 24")



## POWERPAD Bag -Snare Drum-

### PBS1455

5.5"x14" Snare Drum

- PBS1455 (5.5" x 14")
- PBS1465 (6.5" x 14")
- PBS1480 (8" x 14")



## POWERPAD Bag -Hardware-

### PBH02L

880 (L) x 150 (W) x 200 (H) mm



## POWERPAD Bag -Hardware-

### PBH05

850 (L) x 320 (W) x 220 (H) mm



## POWERPAD Bag -Cymbal-

### PBC22

22" compartment dividers (3pcs) and 15" compartment dividers (3pcs) Included.



## POWERPAD Bag -Twin Pedal-

### PBP200

200 (D) x 450 (W) x 300 (H) mm



## POWERPAD Bag -Single Pedal-

### PBP100

220 (D) x 190 (W) x 400 (H) mm



## POWERPAD Bag -Drum Throne-

### PBTH15

-Carries any TAMA drum throne  
-Carries 14" snare drum and snare drum stand



## POWERPAD Bag -Stick-

### PBS50

Stores about 24 pairs of sticks & mallets



## POWERPAD Bag -Stick-

### PBS24

Stores about 12 pairs of sticks & mallets



## POWERPAD Bag -Stick-

### TSB12BK

Black  
Stores about 6 pairs of sticks



## POWERPAD Bag -Stick-

### TSB12BE

Beige  
Stores about 6 pairs of sticks



## POWERPAD Bag -Stick-

### TSB12NB

Navy Blue  
Stores about 6 pairs of sticks



## POWERPAD Bag -Stick-

### TSB12WR

Wine Red  
Stores about 6 pairs of sticks



## LZ SERIES STICK BAG

### LZ-STB01BK

Stores about 12 pairs of sticks & mallets



## LZ SERIES STICK BAG

### LZ-STB02BK

Stores about 6 pairs of sticks



## STANDARD SERIES DRUM BAG SET

### DSS52K

18"x22"BD  
8"x10"TT  
9"x12"TT  
16"x16"FT  
6.5"x14"SD



## STANDARD SERIES DRUM BAG SET

### DSS52H

18"x22"BD  
6.5"x10"TT & 7"x12"TT (1 bag)  
16"x16"FT  
6.5"x14"SD



## STANDARD SERIES DRUM BAG SET

### DSS52S

18"x22"BD  
9"x12"TT  
10"x13"TT  
16"x16"FT  
6.5"x14"SD



## STANDARD SERIES DRUM BAG SET

### DSS50S

18"x20"BD  
8"x10"TT  
9"x12"TT  
14"x14"FT  
6.5"x14"SD



## STANDARD SERIES DRUM BAG SET

### DSS62S

18"x22"BD  
8"x10"TT  
9"x12"TT  
14"x14"FT  
16"x16"FT  
6.5"x14"SD



## STANDARD SERIES DRUM BAG SET

### DSS62H

18"x22"BD  
6.5"x10"TT & 7"x12"TT (1 bag)  
14"x14" FT  
16"x16"FT  
6.5"x14"SD



## STANDARD SERIES SNARE BAG

### SBS14

6.5"x14" Snare Drum





# ACCESSORIES

We offer many unique accessories to enhance your playing, set up, and tone of the drums.



## RHYTHM WATCH

### RW200

Tempo Range: 30-250 BPM  
Tempo, Beat & Sound  
Memory: 30 Songs  
Beats: 0-9  
Display: LCD with BACK LIGHT  
Size: 127 x 35 x 150mm  
(5" x 1.4" x 6")  
Weight: 285g including battery  
Power Supply: 9V Battery (S-006P) or DC9V 200mA adapter



## RHYTHM WATCH MINI

### RW30

Tempo Range: 30-250 BPM  
Beats: 0-9  
Display: LCD display with BACK LIGHT  
Size: 61 x 25 x 118mm (2 1/2" x 1" x 4 5/8")  
Weight: 90g including battery  
Power Supply: 2 x AAA Batteries (3V)



## RHYTHM WATCH HOLDER

### RWH10

for RW200, RW105 & RW100



## TENSION WATCH

### TW200

The TW200 TAMA Tension Watch is very compact and is equipped with an easy to read dial. It comes with a detachable nylon bumper to ensure consistent measuring distance from the hoop, resulting in an evenly tensioned drum for the best sound.



## TENSION WATCH CARRYING CASE

### TW2B

for TW200  
This case is specially designed to carry the TW200 Tension Watch safely and securely.



## TENSION WATCH

### TW100

The TW100 measures actual head tension and features an easy-to-read meter, so you can record the numbers and duplicate your best tuning time after time. You can also use the sample tunings suggested in the directions.



## DRUMMER'S GLOVE

### TDG10M/L

TDG10M (Medium)  
TDG10L (Large)



## WOOD HOOP PROTECTOR

### WHP2

(2pcs/set)  
Special adhesive pieces protect your wood hoop from being scratched by preventing the bass drum pedal from twisting or slipping.

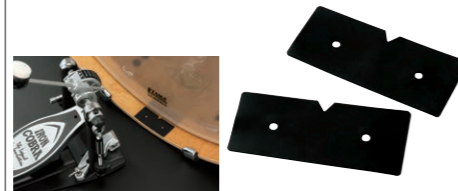

## MULTI TOOL

### TMT9

-Quick access multi tool for drums  
-Hex Wrench 5.0mm/4.0mm/3.0mm/2.5mm/2.0mm, Keychain Link, Hex Nut Driver (7mm), Phillips Screwdriver, Drum Keys (x2)



## STAND WEIGHT

### TSW10 NEW

TAMA hardware is highly regarded for its quality and stability. But sometimes you need a little extra stability – either for extremely hard hitting, or if the playing surface is uneven. To meet that need, we present TAMA Stand Weights, which enable you to stabilize your stand firmly on any surface simply by looping the weight around the tripod base.

Weight: 3kg (6.6lb)



## DRUM RUG

### TDR-TL NEW

TAMA Logo Pattern  
1800mm x 2000mm

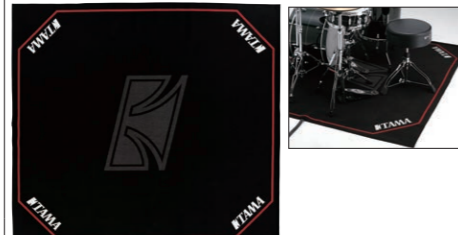

## DRUM RUG

### TDR-OR NEW

Oriental Pattern  
1800mm x 2000mm

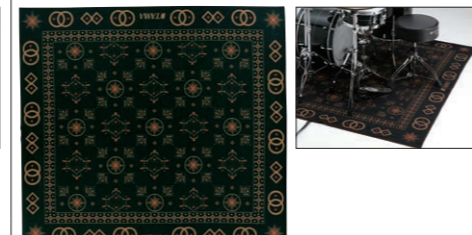

## BASS DRUM HEAD

### RF22BMST (22")

REMO Powerstroke P3 Fiberskyn Bass Diplomat

RF18BMST (18")  
RF20BMST (20")  
RF22BMST (22")  
RF24BMST (24")  
RF26BMST (26")



## BASS DRUM HEAD

### CT22BMOT (22")

White Coated Heads  
(TAMA & Starclassic Logo)

CT18BMOT (18")  
CT20BMOT (20")  
CT22BMOT (22")  
CT24BMOT (24")  
CT26BMOT (26")



## BASS DRUM HEAD

### FB22BMFS (22")

Fiber Laminated Heads  
(TAMA & Starclassic Logo)

FB18BMFS (18")  
FB20BMFS (20")  
FB22BMFS (22")  
FB24BMFS (24")



## BASS DRUM HEAD

### BK22BMST (22")

Black Heads  
(TAMA & Starclassic Logo)

BK18BMST (18")  
BK20BMST (20")  
BK22BMST (22")  
BK24BMST (24")  
BK26BMST (26")



## BASS DRUM HEAD

### SW22BMST (22")

Smooth White Heads  
(TAMA & Starclassic Logo)

SW20BMST (20")  
SW22BMST (22")  
SW24BMST (24")



## BASS DRUM HEAD

### BK22BMFH (22")

Fiber Laminated Heads (Black)  
(TAMA Logo for Superstar Hyper-Drive)

BK22BMFH (22")  
BK24BMFH (24")

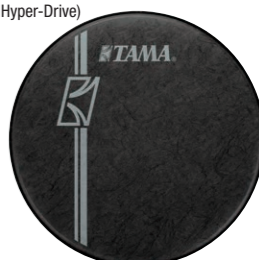

## BASS DRUM HEAD

### CT22BMSV (22")

White Coated Heads  
(TAMA Logo)

CT18BMSV (18")  
CT20BMSV (20")  
CT22BMSV (22")  
CT24BMSV (24")



## BASS DRUM HEAD

### BK22BMWS (22")

Black Heads  
(TAMA Logo)

BK20BMWS (20")  
BK22BMWS (22")  
BK24BMWS (24")



## BASS DRUM HEAD

### CT16BMMJ

16"/ "Metro-JAM" Kit front side



## BASS DRUM HEAD

### CL16BMSMJ

16"/ "Metro-JAM" Kit batter side



## DRUM KEY

### TDK10

(Chrome)

### TDK10BN

(Black Nickel)



## DRUM KEY

### 6560R



## SNARE DRUM HOOP

### MDH14-10

Die-Cast Hoops

Made of die-cast zinc, TAMA's die-cast hoops deliver an incredibly sharp, solid rim shot that cannot be found in any other hoop.

MDH13-8 (13" 8 hole batter side)  
MDH13S-8 (13" 8 hole snare side)  
MDH14-8 (14" 8 hole batter side)  
MDH14S-8 (14" 8 hole snare side)  
MDH14-10 (14" 10 hole batter side)  
MDH14S-10 (14" 10 hole snare side)



## SNARE DRUM HOOP

### MFB14-10N

2.3mm Brass Mighty Hoops

2.3mm brass provides a milder attack and more sustain than steel of the same thickness.

MFB14-10N (14" 10 hole batter side)  
MFB14S-10N (14" 10 hole snare side)



## SNARE DRUM HOOP

### MFM14-10

2.3mm Steel Mighty Hoops

TAMA's triple flanged 2.3mm steel hoops provide a "wetter" sound than die-cast zinc hoops.

MFM13-8 (13" 8 hole batter side)  
MFM13S-8 (13" 8 hole snare side)  
MFM14-8 (14" 8 hole batter side)  
MFM14S-8 (14" 8 hole snare side)  
MFM14-10 (14" 10 hole batter side)  
MFM14S-10 (14" 10 hole snare side)





**SNARE DRUM HOOP**  
**MSH1410**  
 2.3mm Sound Arc Hoops

The Sound Arc Hoop was specially developed for S.L.P. Snare drums. This inward curved 2.3mm steel hoop enhances the natural tone of the snare drum, and offers sensitivity, precise tuning, and control.

MSH138 (13" 8 hole batter side)  
 MSH13S8 (13" 8 hole snare side)  
 MSH1410 (14" 10 hole batter side)  
 MSH14S10 (14" 10 hole snare side)



**SNARE DRUM HOOP**  
**MSB148D** NEW  
 2.3mm Brass Sound Arc Hoops

The Sound Arc Brass Hoop was specially developed for STAR Reserve Solid Maple snare drum. This inward curved 2.3mm brass hoop provides milder attack, more sustain and offers sensitivity, precise tuning, and control.

MSB148D (14" 8 hole batter side)  
 MSB14S8D (14" 8 hole snare side)



**SNARE DRUM HOOP**  
**WMH1408B**  
 Maple Wood Hoops

This 100% maple wood was specially developed for S.L.P. Snare drums. The 22 mm thick hoops provides warm sound and powerful attack especially rim shot.

WMH1408B (14" 8 hole batter side)  
 WMH1408S (14" 8 hole snare side)



**SNARE WIRE STRAPS**  
**MST20**  
 (2pcs/set)

These flexible yet durable 15mm wide nylon snare wire straps are featured on all TAMA snare drums except STAR, STARPHONIC, JD146 and PE106M



**SNARE WIRE CORDS**  
**SPC50P4**  
 (2prs/pack)

The amazingly durable and flexible snare wire cord is made of Dupont Kevlar® cable wrapped in polyester fiber for an even higher tensile strength than steel wire. (Kevlar® is a registered trademark of Dupont® Corporation.)



**DRUM CLEANING CLOTH**  
**TDC1000**



**SNARE WIRE**  
**MS20RL14C**  
 Super Sensitive Hi-Carbon Snare Wires

MS20RL13C (13" 20 strands hi-carbon steel)  
 MS20RL14C (14" 20 strands hi-carbon steel)

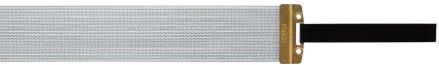

**SNARE WIRE**  
**MS20SN14S**  
 Starclassic Snare Wires (Carbon Steel)

MS20SN10S (10" 20 strands Carbon Steel)  
 MS20SN12S (12" 20 strands Carbon Steel)  
 MS20SN13S (13" 20 strands Carbon Steel)  
 MS20SN14S (14" 20 strands Carbon Steel)



**SNARE WIRE**  
**MS20SN14B**  
 Starclassic Snare Wire (Bell Brass)

MS20SN14B (14" 20 strands Bell Brass)



**POWER-STRIKE COBRA BEATER**  
**CB900PS**  
 Felt



**ACCU-STRIKE COBRA BEATER**  
**CB900AS**  
 Rubber



**PROJECTOR BEATER**  
**PB90F**  
 Felt



**SNARE WIRE**  
**MS20SN14C**  
 Starclassic Snare Wires (Hi-Carbon Steel)

MS20SN13C (13" 20 strands Hi-Carbon Steel)  
 MS20SN14C (14" 20 strands Hi-Carbon Steel)

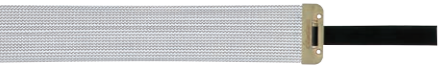

**SNARE WIRE**  
**MS12R14S**  
 Regular Snare Wire (Carbon Steel)

MS12R14S (14" 12 strands Carbon Steel)



**SNARE WIRE**  
**MS20R14S**  
 Regular Snare Wire (Carbon Steel)

MS20R14S (14" 20 strands Carbon Steel)



**COBRA BEATER - FELT-**  
**CB90F**  
 Felt



**COBRA BEATER - RUBBER-**  
**CB90R**  
 Rubber



**COBRA BEATER - WOOD-**  
**CB90W**  
 Wood



**SNARE WIRE**  
**MS30R14S**  
 Regular Snare Wire (Carbon Steel)

MS30R14S (14" 30 strands Carbon Steel)



**SNARE WIRE**  
**MS42R14S**  
 Regular Snare Wire (Carbon Steel)

MS42R14S (14" 42 strands Carbon Steel)

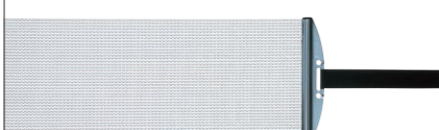

**SNARE WIRE**  
**MS42R14C**  
 Regular Snare Wire (Hi-Carbon Steel)

MS42R14C (14" 42 strands Hi-Carbon Steel)



**POWER-STRIKE COBRA BEATER HEAD**  
**CB900PSH**  
 Felt



**ACCU-STRIKE COBRA BEATER HEAD**  
**CB900ASH**  
 Rubber



**PROJECTOR BEATER HEAD**  
**PB90FH**  
 Felt



**HOLD TIGHT™ WASHERS**  
**SRW620P** (US.PAT.NO.7307204)  
 (20pcs/set)

The rubber rings inside of the cup-shaped stainless steel washers absorb impact vibrations and keep the hoop and tension bolts in constant contact to prevent from loosening of tension.

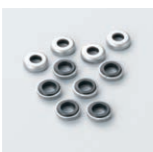

**NYLON WASHERS**  
**PW620**  
 (20pcs/set)

2.5mm thick nylon washers decrease noise and make tuning easier and more stable.



**METAL WASHERS**  
**MW620**  
 (20pcs/set)

Standard metal tension bolt washers.



**COBRA BEATER HEAD - FELT-**  
**CB90FH**  
 Felt



**COBRA BEATER HEAD - RUBBER-**  
**CB90RH**  
 Rubber



**COBRA BEATER HEAD - WOOD-**  
**CB90WH**  
 Wood





**DUAL SIDED BEATER -FELT-**  
**DS30**  
 Felt



**DUAL SIDED BEATER -FELT-**  
**DS30G**  
 Felt



**DUAL SIDED BEATER -RUBBER-**  
**DS30R**  
 Rubber



**TRADITIONAL BEATERS**  
**TTB30F**  
 Felt  
**TTB30W**  
 Wood



**TOE STOPPER**  
**HP900-81**



**BEATER BALANCER**  
**BC7**



**TIGHT LOCK**  
**TLK5**

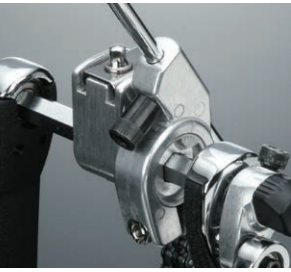

**SPRING FOR SPEED COBRA**  
**HP910-7S**



**SPRINGS**  
**HP900-7R**  
 Regular  
**HP900-7H**  
 Heavy

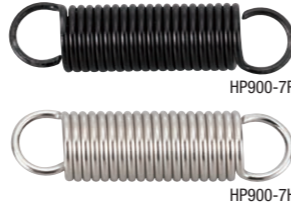

**COBRA COIL**  
**CC900S**

The Cobra Coil is a steel spring which assists in the return of the footboard to its original position, so the feel of Speed Cobra becomes even more unreal. Even better, the Cobra Coil can be adjusted to different positions, forward or backward, on the base plate.



**DRUM HAMMER**  
**DH7**



**TWIN PEDAL ATTACHMENT**  
**TPA90**

Specially designed attachment to connect Speed Cobra and Iron Cobra 900 series pedals with Speed Cobra and Iron Cobra 900 series Hi-hat stands.



**IRON COBRA PEDAL CASES**  
**PC900S/PC900TW**  
 PC900S (for Iron Cobra Single Pedal)  
 PC900TW (for Iron Cobra Twin Pedal)



**SPEED COBRA PEDAL CASES**  
**PC910S/PC910TW**  
 PC910S (for Speed Cobra Single Pedal)  
 PC910TW (for Speed Cobra Twin Pedal)



**1st CHAIR THRONE SEAT**  
**HTS8BC** **NEW**  
 Round Rider XL "Cloth Top"



**1st CHAIR THRONE SEAT**  
**HTS8B** **NEW**  
 Round Rider XL



**1st CHAIR THRONE SEAT**  
**HTS8R** **NEW**  
 Round Rider XL "Red"



**1st CHAIR THRONE SEAT**  
**HTS7BC** **NEW**  
 Ergo-Rider "Cloth Top"



**1st CHAIR THRONE SEAT**  
**HTS7B** **NEW**  
 Ergo-Rider



**1st CHAIR THRONE SEAT**  
**HTS5BC** **NEW**  
 Wide Rider "Cloth Top"



**1st CHAIR THRONE SEAT**  
**HTS5B** **NEW**  
 Wide Rider



**1st CHAIR THRONE SEAT**  
**HTS4BC** **NEW**  
 Round Rider "Cloth Top"



**1st CHAIR THRONE SEAT**  
**HTS4B** **NEW**  
 Round Rider



**1st CHAIR THRONE BASE**  
**HSB5N** **NEW**  
 HYDRAULIX  
 \*Seat holder included.



**1st CHAIR THRONE BASE**  
**HSB4N** **NEW**  
 Quartet



**1st CHAIR THRONE BASE**  
**HSB3N** **NEW**  
 Trio



**1st CHAIR THRONE BASE**  
**HSB3**  
 Trio for Round Rider 430 Series



**1st CHAIR BACKREST**  
**HTB5B** **NEW**  
 1st Chair Backrest Attachment



**TAMA LOGO STICKER -White-**  
**TLS100WH**  
 TLS120WH (60mm x 280mm)  
 TLS100WH (50mm x 230mm)  
 TLS80WH (40mm x 190mm)  
 TLS70WH (35mm x 150mm)



**TAMA LOGO STICKER -Black-**  
**TLS100BK**  
 TLS120BK (60mm x 280mm)  
 TLS100BK (50mm x 230mm)  
 TLS80BK (40mm x 190mm)  
 TLS70BK (35mm x 150mm)







**TUNE-UP OIL**  
**TOL2**  
 Machine oil for lubricating the moving parts of stands, pedals, and tension bolts. Also protects pedal chains from rust.



**SONIC MUTE**  
**TSM01**  
 (2pcs/set)  
 Removable, reusable & reliable mute patch. Adjustable for optimum precision and control. (Wash lightly to restore adhesion).



**MEMORY LOCK**  
**ML11**  
 for 10.5mm diameter L-rod



**REVERSIBLE CYMBAL BOTTOM**  
**RB8P**  
 (2pcs/pack)



**STAR HW CYMBAL BOTTOM**  
**CB8P**  
 (2pcs/pack)



**CYMBAL PROTECTION SLEEVE**  
**CPS8P**  
 (2pcs/pack)



**MEMORY LOCK**  
**ML12**  
 for 10.5mm-12mm diameter boom arm



**MEMORY LOCK**  
**ML191C**  
 for 19.1mm diameter pipe



**MEMORY LOCK**  
**ML191N**  
 for 19.1mm diameter pipe



**QUICK-SET HI-HAT CLUTCH**  
**QHC7** NEW  
 (PAT.PENDING)  
 With just one touch, the Quick-Set Hi-Hat Clutch can be attached or removed - simply push the button on the side of the clutch. The clutch also allows the top hi-hat cymbal to float more freely, maximizing the natural resonance of the cymbals. (Fits 7mm or smaller diameter pull rod)



**SWING LOCK CLUTCH**  
**SLC08**  
 This allows the top hi-hat cymbal to float more freely, maximizing the natural resonance of the cymbals. (Fits 6.3mm diameter pull rod)



**SECURITY CLUTCH**  
**CL08**  
 Having your hi-hat clutch come loose is now a thing of the past with TAMA's Security Clutch. When the T-bolt is tightened, bottom lock nut and top section press on the rod for complete security. (Fits 6.3mm diameter pull rod)



**MEMORY LOCK**  
**ML222C**  
 for 22.2mm diameter pipe



**MEMORY LOCK**  
**ML222NT**  
 for 22.2mm diameter pipe



**MEMORY LOCK**  
**ML254TC**  
 for 25.4mm diameter pipe



**HI-HAT TENSION RODS**  
**HH905D3S/HH905-3**  
 Tension Rod w/ Plastic Nut (M6)  
 HH905-3 (Long, 500mm)  
 HH905D3S (Short, 350mm) NEW



**HI-HAT CLUTCH FELT WASHERS**  
**CL08-13P**  
 (2pcs/pack)



**QUICK-LOCK TOM BRACKET**  
**MQMP-TCH**  
 (for tom tom/Chrome)  
 -Quick and easy setup in position  
 -Enhanced resonance with rubber lining



**MEMORY LOCK**  
**ML254C**  
 for 25.4mm diameter pipe



**MEMORY LOCK**  
**ML28C**  
 for 28.6mm diameter pipe



**QUICK-SET CYMBAL MATE**  
**QC8**  
 (M8, 1pc)  
**QC8-B4**  
 (M8, 4pcs/pack)



**QUICK-LOCK TOM BRACKET**  
**MQMP-TBN**  
 (for tom tom/Black Nickel)  
 -Quick and easy setup in position  
 -Enhanced resonance with rubber lining



**QUICK-LOCK TOM BRACKET**  
**MQMP-FCH**  
 (for floor tom/Chrome)  
 -Quick and easy setup in position  
 -Enhanced resonance with rubber lining



**QUICK-LOCK TOM BRACKET**  
**MQMP-FBN**  
 (for floor tom/Black Nickel)  
 -Quick and easy setup in position  
 -Enhanced resonance with rubber lining



**CYMBAL MATE**  
**CM8P**  
 (M8, 2pcs/pack)



**RING-TRUE CYMBAL FELT**  
**RTF35P**  
 (2pcs/pack)



**FELT WASHER**  
**7081P**  
 (2pcs/pack)





# DRUM STICKS

TAMA drum sticks have been produced for over 30 years at our specialized stick factory in Japan. Our sticks are molded under strict quality control standards from carefully selected wood materials and are renowned for their consistent high quality.

## ORIGINAL SERIES

The Original series utilizes TAMA's unique size system. The grip diameter, tip shape, and material can be easily determined using the product number.

### Japanese Oak



Tip Style	Model No.		Diameter	Length
	Japanese Oak	American Hickory		
	0213-B	H213-B	13mm	406mm
	0214-B	H214-B	14mm	
	0215-B	H215-B	15mm	
	0216-B	-	16mm	
	0213-P	H213-P	13mm	
	0214-P	H214-P	14mm	
	0215-P	H215-P	15mm	
	0214-S	-	14mm	
	0215-S	-	15mm	

### American Hickory



## Tip Styles



**B : Ball**  
This is the most popular tip shape due to its ability to produce consistent notes. A great stick for beginners as well as pros.



**P : Popular**  
The teardrop shape allows you to change and control the sound according to how you hit the heads and cymbals.

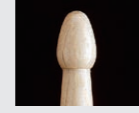

**S : Small**  
Smaller tips offer subtlety, volume control, clarity and precision.

## TRADITIONAL SERIES

The Traditional series utilizes the traditional size system including stick sizes such as 7A and 5B. Even players buying TAMA sticks for the first time can easily find the sticks that are right for them.

### Japanese Oak



Tip Style	Model No.		Diameter	Length
	Japanese Oak	American Hickory		
	7A	H7A	13mm	390mm
	7AN	-		
	5A	H5A	14mm	406mm
	5AN	-		
	8A	H8A		
	5B	H5B	15mm	
	5BN	-		

### American Hickory



## Tip Styles

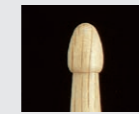

**7A**  
The 7A's small tip size is superb for subtle and legato cymbal work, and performs superbly in the jazz environment.

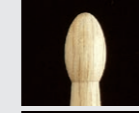

**5A**  
Oval-shaped (teardrop) tip. Balanced towards the tip end for quick sound and response. The great size, weight, and balance are perfect for all-round use.



**8A**  
The small tip allows for subtle nuances. The sharpened square-shaped tip point also enables enhanced clarity.

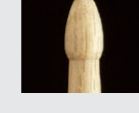

**5B**  
Sharpened tip that provides rich, full-volume sound. Subtle nuances are possible by playing at different angles.

## CANVAS SERIES

Canvas sticks feature two bright colors and a dark green color.



Tip Style	Model No.			Diameter	Length
	Japanese Oak				
	Green, Silver Printing	Light Blue, Blue Printing	White, Blue Printing	14mm	406mm
	5ACV-DG	5ACV-LB	5ACV-WH		

## STAGEMAX

Stagemax sticks forgo a paint finish and utilize the texture of wood for a more natural and comfortable grip. For drummers who work up a sweat while playing and sometimes find their sticks slipping away from them, these sticks are the answer.



Tip Style	Model No.		Diameter	Length
	Japanese Oak	American Hickory		
	5A-MS	H5A-MS	14mm	406mm
	5B-MS	H5B-MS		

## REDZONE

Featuring the strong attack of nylon tips as well as being crafted slightly longer than normal at 419mm, RedZone series sticks are tailor-made for power hitters. In addition, using the "Knocker" type which features a non-tapered, grip-end shape at both ends makes it possible to get an even bigger sound.



Tip Style	Model No.		Diameter	Length
	Japanese Oak Silver Logo	American Hickory Gold Logo		
	5ARZ	H5ARZ	14mm	419mm
	5BRZ	H5BRZ		
	5ARZK	H5ARZK	14mm	419mm

## RHYTHMIC FIRE

The Rhythmic Fire sticks feature an original TAMA tribal graphic design.



Tip Style	Model No.			Diameter	Length
	Japanese Oak				
	Natural	Black, Silver Pattern	Black, Red Pattern	13mm	390mm
	7A-F	7A-F-BS	7A-F-BR		
	5A-F	5A-F-BS	5A-F-BR	14mm	406mm
	5B-F	5B-F-BS	5B-F-BR		

## STICKS OF DOOM

The "Sticks of Doom" feature an original TAMA skull and bones graphic design.



Tip Style	Model No.		Diameter	Length
	Japanese Oak			
	Natural	Black, Silver Pattern	13mm	390mm
	7A-S	7A-S-BS		
	5A-S	5A-S-BS	14mm	406mm
	5B-S	5B-S-BS		

## SIGNATURE MODELS



### DIRK VERBEUREN MODEL NEW

Dirk Verbeuren (MEGADETH)

Tip Style	Model No.	Diameter	Length
	Japanese Oak 0-DVM	16mm	406mm



### MARIO DUPLANTIER MODEL

Mario Duplantier (Gojira)

Tip Style	Model No.	Diameter	Length
	American Hickory H-MD	16.5mm	432mm



### JEREMY COLSON MODEL NEW

Jeremy Colson (Steve Vai)

Tip Style	Model No.	Diameter	Length
	American Hickory H-JCS	16.5mm	422mm



### YOSHIKI MODELS

YOSHIKI (X-JAPAN/VIOLET UK)

Tip Style	Model No.	Diameter	Length
	American Hickory H-YKM	14.25mm	398mm
	American Hickory H-YKB	14.25mm	398mm