



 **TAMA**

2019 GENERAL CATALOG
DRUMS AND HARDWARE

TABLE OF CONTENTS

4-9	STAR Drums	58-59	Cymbal Stands
10-19	Starclassic	60-61	Tom Stands & Tom Holders
20-25	S.L.P. Drum Kits	62	Hardware Kits
26-27	Superstar Hyper-Drive Duo	62-63	Power Tower System
28-31	Superstar Hyper-Drive	63-67	Clamps & Attachments
32-37	Superstar Classic	68-69	Microphone Stands & Accessories
38-39	Imperialstar	70-72	TAMA Percussion
40	Rhythm Mate	72-73	Practice Tools
41-43	Club-JAM & Club-JAM Mini	74-78	Bags
44	Cocktail-JAM	79-91	Accessories
45-50	Snare Drums	92-98	Sticks
51-52	Drum Pedals		
53-54	Hi-hat Stands		
54-56	Drum Thrones		
56-57	Snare Stands		





MA®

TAMA STAR BUBINGA

Lacquer Finishes

STAR is the flagship line for TAMA drums. It takes the knowledge and research we cultivated for the Starclassic series to the next level, by reexamining every detail to enhance shell resonance. STAR Bubinga features a thin 5mm shell. Every shell comes equipped with 9mm thick Sound Focus Rings (SFR) for structural support. This shell configuration provides clear projection and resonance to highlight the distinct sound of Bubinga.



COLOR Solid Candy Red **SDR**

including:
16"x20" bass drum
7"x8" tom tom
7"x10" tom tom
7"x12" tom tom
7.5"x13" tom tom
12"x14" floor tom
14"x16" floor tom
6.5"x14" snare drum



COLOR Natural Indian Laurel **LNTI**

including:
18"x22" bass drum
7"x10" tom tom
8"x12" tom tom
14"x14" floor tom
16"x16" floor tom
6.5"x14" snare drum

INDIVIDUAL MODEL NUMBERS

Diameter	Depth	Model No.
Bass Drums		
18"	14"	TBB1814S
18"	15"	TBB1815S
18"	16"	TBB1816S
20"	14"	TBB2014S
20"	16"	TBB2016S
20"	17"	TBB2017S
20"	18"	TBB2018S
22"	14"	TBB2214S
22"	16"	TBB2216S
22"	17"	TBB2217S
22"	18"	TBB2218S
24"	14"	TBB2414S
24"	16"	TBB2416S
24"	17"	TBB2417S
24"	18"	TBB2418S
26"	14"	TBB2614S
26"	16"	TBB2616S
Floor Toms		
14"	12"	TBF1412S
14"	13"	TBF1413S
14"	14"	TBF1414S
15"	13"	TBF1513S
15"	14"	TBF1514S
15"	15"	TBF1515S
16"	14"	TBF1614S
16"	15"	TBF1615S
16"	16"	TBF1616S
18"	14"	TBF1814S
18"	15"	TBF1815S
18"	16"	TBF1816S

Diameter	Depth	Model No.
Tom Toms		
8"	6"	TBT0806S
8"	7"	TBT0807S
8"	8"	TBT0808S
10"	6.5"	TBT1065S
10"	7"	TBT1007S
10"	8"	TBT1008S
10"	9"	TBT1009S
10"	10"	TBT1010S
12"	7"	TBT1207S
12"	8"	TBT1208S
12"	9"	TBT1209S
12"	10"	TBT1210S
12"	11"	TBT1211S
13"	7.5"	TBT1375S
13"	9"	TBT1309S
13"	10"	TBT1310S
13"	11"	TBT1311S
13"	12"	TBT1312S
14"	8"	TBT1408S
14"	10"	TBT1410S
14"	11"	TBT1411S
14"	12"	TBT1412S
14"	13"	TBT1413S
Snare Drums		
13"	6"	TBS136S
14"	5.5"	TBS1455S
14"	6.5"	TBS1465S
14"	8"	TBS148S

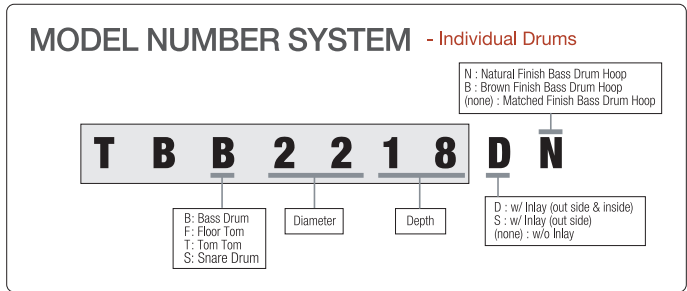

SPECIFICATIONS

Shells
 5mm, 5ply Bubinga + 1 inner ply Cordia or 4ply Bubinga + 1 outer ply Indian Laurel + 1 inner ply Cordia for LNTI, or 4ply Bubinga + 1 outer & 1 inner ply Cordia for CDKG/CDKR/CSTN, w/ 9mm Sound Focus Rings

STAR Bearing Edges
 Super Resonant Mounting System
 Quick-Lock Tom Brackets
 Minimum Shell Contact
 STAR Floor Tom Legs
 Hold Tight™ Washers
 Remo® Drum Heads

FINISHES (Lacquer)

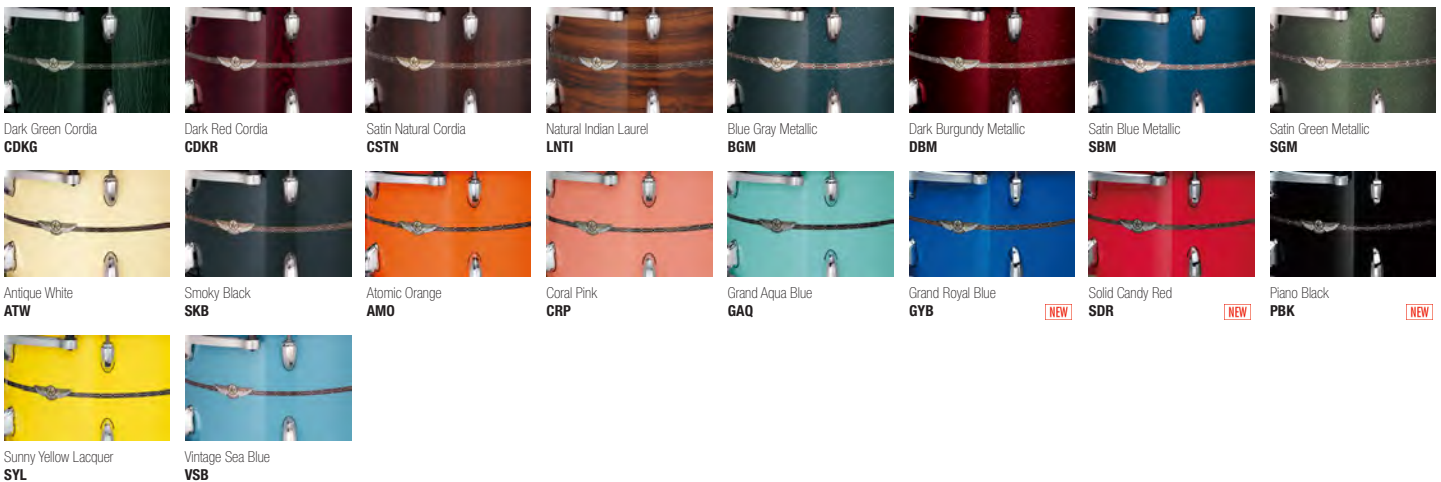

TAMA STAR MAPLE

Lacquer Finishes

STAR is the flagship line for TAMA drums. It takes the knowledge and research we cultivated for the Starclassic series to the next level, by reexamining every detail to enhance shell resonance. STAR Maple shell's "Solid Core Ply" is a totally new design for this series. This unique shell provides the warm, open tone of Maple, combined with the rich, hearty sound of a solid ply shell.



COLOR Grand Royal Blue **GYB**

including:
16"x22" bass drum
7"x10" tom tom
8"x12" tom tom
14"x14" floor tom
16"x16" floor tom
6.5"x14" snare drum



COLOR Raspberry Curly Maple **RRCM**

including:
14"x18" bass drum
8"x12" tom tom
14"x14" floor tom
5.5"x14" snare drum

INDIVIDUAL MODEL NUMBERS

Diameter	Depth	Model No.
Bass Drums		
18"	14"	TMB1814S
18"	15"	TMB1815S
18"	16"	TMB1816S
20"	14"	TMB2014S
20"	16"	TMB2016S
20"	17"	TMB2017S
20"	18"	TMB2018S
22"	14"	TMB2214S
22"	16"	TMB2216S
22"	17"	TMB2217S
22"	18"	TMB2218S
24"	14"	TMB2414S
24"	16"	TMB2416S
24"	17"	TMB2417S
24"	18"	TMB2418S
26"	14"	TMB2614S
26"	16"	TMB2616S
Floor Toms		
14"	12"	TMF1412S
14"	13"	TMF1413S
14"	14"	TMF1414S
15"	13"	TMF1513S
15"	14"	TMF1514S
15"	15"	TMF1515S
16"	14"	TMF1614S
16"	15"	TMF1615S
16"	16"	TMF1616S
18"	14"	TMF1814S
18"	15"	TMF1815S
18"	16"	TMF1816S

Diameter	Depth	Model No.
Tom Toms		
8"	6"	TMT0806S
8"	7"	TMT0807S
8"	8"	TMT0808S
10"	6.5"	TMT1065S
10"	7"	TMT1007S
10"	8"	TMT1008S
10"	9"	TMT1009S
10"	10"	TMT1010S
12"	7"	TMT1207S
12"	8"	TMT1208S
12"	9"	TMT1209S
12"	10"	TMT1210S
12"	11"	TMT1211S
13"	7.5"	TMT1375S
13"	9"	TMT1309S
13"	10"	TMT1310S
13"	11"	TMT1311S
13"	12"	TMT1312S
14"	8"	TMT1408S
14"	10"	TMT1410S
14"	11"	TMT1411S
14"	12"	TMT1412S
14"	13"	TMT1413S
Snare Drums		
13"	6"	TMS136S
14"	5.5"	TMS1455S
14"	6.5"	TMS1465S
14"	8"	TMS148S

SPECIFICATIONS

Shells
 5mm, 5ply Maple, or 5ply Maple + 1 outer ply Sycamore for MGSM, or 5ply Maple + 1 outer ply Curly Maple for ROLC/RRCM
 w/ 5mm Sound Focus Rings

STAR Bearing Edges
 Super Resonant Mounting System
 Quick-Lock Tom Brackets
 Minimum Shell Contact
 STAR Floor Tom Legs
 Hold Tight™ Washers
 Remo® Drum Heads

MODEL NUMBER SYSTEM - Individual Drums

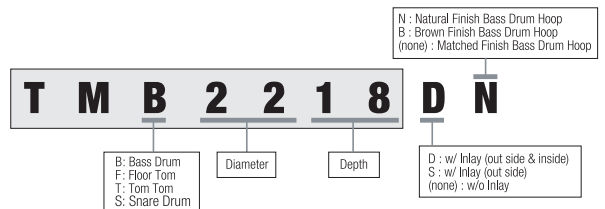

FINISHES (Lacquer)

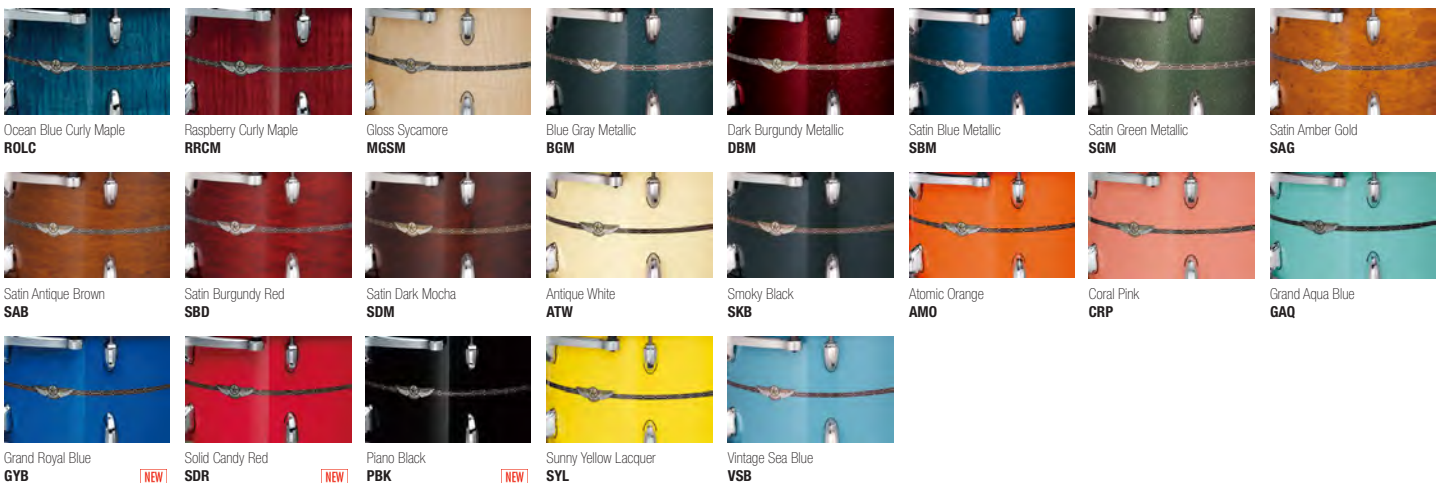

TAMA STAR WALNUT

Lacquer Finishes

STAR is the flagship line for TAMA drums. It takes the knowledge and research we cultivated for the Starclassic series to the next level, by reexamining every detail to enhance shell resonance. Walnut has long been favored by furniture makers for both its beauty and durability. As a drum shell material, Walnut's naturally EQ'ed tone has been praised by the drum community for both the stage and the studio. The STAR Walnut shells project booming low end with enough cut to be heard through any mix.



COLOR Garnet Japanese Sen Burst **AGJB**

TW42RZS basic kit

including:
16"x22" bass drum
7"x10" tom tom
8"x12" tom tom
16"x16" floor tom

[add-on]
6.5"x14" snare drum

KIT CONFIGURATIONS LIST

[22"BD 4pc Shell Kit]

TW42RZS

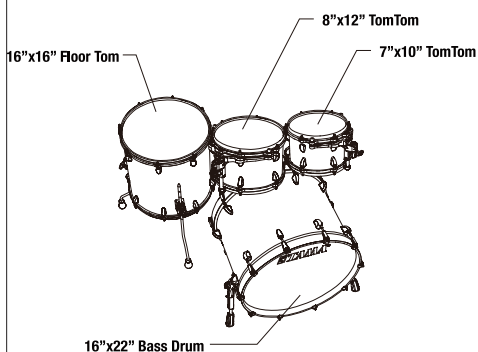

INDIVIDUAL MODEL NUMBERS

Diameter	Depth	Model No.
Bass Drums		
18"	14"	TWB1814
18"	15"	TWB1815
18"	16"	TWB1816
20"	14"	TWB2014
20"	16"	TWB2016
20"	17"	TWB2017
20"	18"	TWB2018
22"	14"	TWB2214
22"	16"	TWB2216
22"	17"	TWB2217
22"	18"	TWB2218
24"	14"	TWB2414
24"	16"	TWB2416
24"	17"	TWB2417
24"	18"	TWB2418
26"	14"	TWB2614
26"	16"	TWB2616
Floor Toms		
14"	12"	TWF1412
14"	13"	TWF1413
14"	14"	TWF1414
15"	13"	TWF1513
15"	14"	TWF1514
15"	15"	TWF1515
16"	14"	TWF1614
16"	15"	TWF1615
16"	16"	TWF1616
18"	14"	TWF1814
18"	15"	TWF1815
18"	16"	TWF1816

Diameter	Depth	Model No.
Tom Toms		
8"	6"	TWT0806
8"	7"	TWT0807
8"	8"	TWT0808
10"	6.5"	TWT1065
10"	7"	TWT1007
10"	8"	TWT1008
10"	9"	TWT1009
10"	10"	TWT1010
12"	7"	TWT1207
12"	8"	TWT1208
12"	9"	TWT1209
12"	10"	TWT1210
12"	11"	TWT1211
13"	7.5"	TWT1375
13"	9"	TWT1309
13"	10"	TWT1310
13"	11"	TWT1311
13"	12"	TWT1312
14"	8"	TWT1408
14"	10"	TWT1410
14"	11"	TWT1411
14"	12"	TWT1412
14"	13"	TWT1413
Snare Drums		
13"	6"	TWS136
14"	5.5"	TWS1455
14"	6.5"	TWS1465
14"	8"	TWS148

MODEL NUMBER SYSTEM - Individual Drums

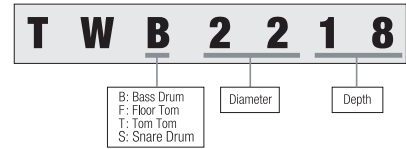









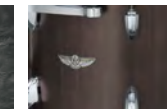
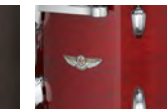
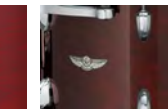
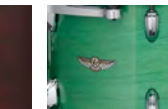
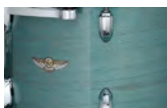
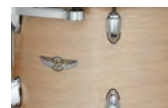

SPECIFICATIONS

Shells
 All Walnut Shell TT/FT/SD: 6mm 6ply, BD: 7mm 7ply (except AJJB, AGJB, ASBJ, ASCS)
 TT/FT/SD: 6mm, 4ply Walnut + 2 outer ply Japanese Sen
 BD: 7mm, 5ply Walnut + 2 outer ply Japanese Sen

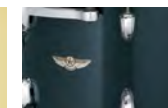
- STAR Bearing Edges
- Super Resonant Mounting System
- Quick-Lock Tom Brackets
- Minimum Shell Contact
- STAR Floor Tom Legs
- Hold Tight™ Washers
- Remo® Drum Heads

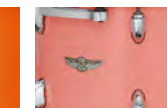
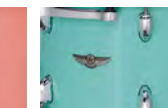
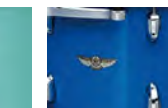
FINISHES (Lacquer)

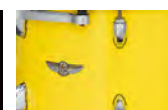
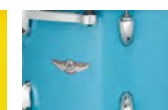
 Indigo Japanese Sen Burst AJB	 Garnet Japanese Sen Burst AGJB NEW	 Satin Black Japanese Sen Burst ASBJ NEW	 Satin Charcoal Japanese Sen ASCS	 Satin Black Walnut WSBN	 Red Burgundy Walnut RBW	 Dark Mocha Walnut DMW	 Mint Green Mist MGN
 Smoky Blue Mist SBU	 Smoky Natural Mist SNM	 Antique White ATW	 Smoky Black SKB	 Atomic Orange AMO	 Coral Pink CRP	 Grand Aqua Blue GAQ	 Grand Royal Blue GYB NEW
 Solid Candy Red SDR	 Piano Black PBK NEW	 Sunny Yellow Lacquer SYL	 Vintage Sea Blue VSB				

STARCLASSIC MAPLE

Exotic Finishes

In the '80s TAMA's Superstars and Imperialstars reigned supreme - the perfect drums for the times. But TAMA's builders and designers wanted something that transcended trends, something timeless - drums that understood a player's passion and allowed the expression of every genre, style, mood, and technique. They created Starclassic Maple drums...and ignited the thin-shell revolution. And now the Exotic Finish line offers beautiful, one-of-a-kind exotic wood exteriors for that extra luxurious touch. Numerous options are available to meet the varied and critical needs of professional drummers including a selection of more than 30 different shell sizes. Starclassic Maple also features three shell hardware finishes to choose from: Black Nickel, Chrome and Smoked Black Nickel. Starclassic Maple is simply an unprecedented combination of sight and sound.



COLOR Violet Fade Movingui
w/ chrome hardware **WLM**

ME42TZS basic kit

including:
16"x22" bass drum
7"x10" tom tom
8"x12" tom tom
16"x16" floor tom

[add-on]
6.5"x14" snare drum

KIT CONFIGURATIONS LIST

[20"BD 3pc Shell Kit]

ME30CMS w/Chrome Hardware
ME30CMBS w/Black Nickel Hardware
ME30CMUS w/Smoked Black Nickel Hardware

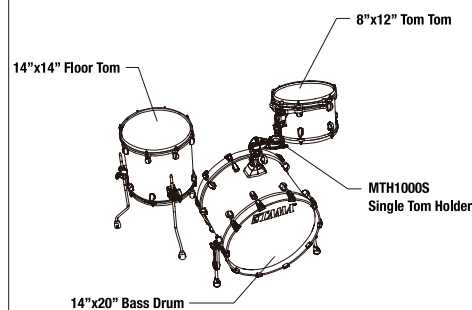

[22"BD 3pc Shell Kit]

ME32CZS w/Chrome Hardware
ME32CZBS w/Black Nickel Hardware
ME32CZUS w/Smoked Black Nickel Hardware

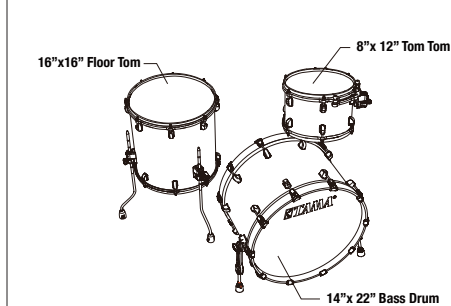

[22"BD 4pc Shell Kit]

ME42TZS w/Chrome Hardware
ME42TZBS w/Black Nickel Hardware
ME42TZUS w/Smoked Black Nickel Hardware

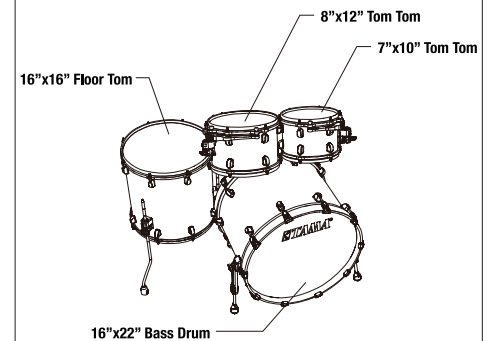

INDIVIDUAL MODEL NUMBERS

Diameter	Depth	Model No.		
		Black Nickel	Chrome	Smoked Black Nickel
Bass Drums				
*To order Bass Drum w/ Tom Holder Base, Please substitute "Z" with "M". Ex MEB2218Z → MEB2218M				
18"	14"	MEB1814ZB	MEB1814Z	MEB1814ZU
18"	16"	MEB1816ZB	MEB1816Z	MEB1816ZU
20"	14"	MEB2014ZB	MEB2014Z	MEB2014ZU
20"	16"	MEB2016ZB	MEB2016Z	MEB2016ZU
20"	18"	MEB2018ZB	MEB2018Z	MEB2018ZU
22"	14"	MEB2214ZB	MEB2214Z	MEB2214ZU
22"	16"	MEB2216ZB	MEB2216Z	MEB2216ZU
22"	18"	MEB2218ZB	MEB2218Z	MEB2218ZU
22"	20"	MEB2220ZB	MEB2220Z	MEB2220ZU
24"	14"	MEB2414ZB	MEB2414Z	MEB2414ZU
24"	16"	MEB2416ZB	MEB2416Z	MEB2416ZU
24"	18"	MEB2418ZB	MEB2418Z	MEB2418ZU
Floor Toms				
14"	12"	MEF1412B	MEF1412	MEF1412U
14"	14"	MEF1414B	MEF1414	MEF1414U
16"	14"	MEF1614B	MEF1614	MEF1614U
16"	16"	MEF1616B	MEF1616	MEF1616U
18"	16"	MEF1816B	MEF1816	MEF1816U
Tom Toms				
8"	6"	MET0806B	MET0806	MET0806U
8"	7"	MET0807B	MET0807	MET0807U
8"	8"	MET0808B	MET0808	MET0808U
10"	6.5"	MET1065B	MET1065	MET1065U
10"	7"	MET1007B	MET1007	MET1007U
10"	8"	MET1008B	MET1008	MET1008U
10"	9"	MET1009B	MET1009	MET1009U
12"	7"	MET1207B	MET1207	MET1207U
12"	8"	MET1208B	MET1208	MET1208U
12"	9"	MET1209B	MET1209	MET1209U
12"	10"	MET1210B	MET1210	MET1210U
13"	7.5"	MET1375B	MET1375	MET1375U
13"	9"	MET1309B	MET1309	MET1309U
13"	10"	MET1310B	MET1310	MET1310U
13"	11"	MET1311B	MET1311	MET1311U
14"	10"	MET1410B	MET1410	MET1410U
14"	11"	MET1411B	MET1411	MET1411U
14"	12"	MET1412B	MET1412	MET1412U
16"	13"	MET1613B	MET1613	MET1613U
16"	14"	MET1614B	MET1614	MET1614U
Snare Drums				
13"	6"	MES136B	MES136	MES136U
14"	5.5"	MES1455B	MES1455	MES1455U
14"	6.5"	MES1465B	MES1465	MES1465U
14"	8"	MES148B	MES148	MES148U

SPECIFICATIONS

Shells

LEWB/LNWB/LRWB
TT/FT: 5mm 6ply Maple + 1 outer ply Pacific Walnut
BD/SD: 7mm 8ply Maple + 1 outer ply Pacific Walnut

VGLM/VOLM/VVLM
TT/FT: 5mm 6ply Maple + 1 outer ply Movingui
BD/SD: 7mm 8ply Maple + 1 outer ply Movingui

Star-Cast Mounting System

Quick-Lock Tom Bracket

EVANS® Heads

Die-Cast Hoops

Hold Tight™ Washers

Claw Hooks w/ Rubber Spacers

Cushioned Floor Tom Legs

MODEL NUMBER SYSTEM - Individual Drums

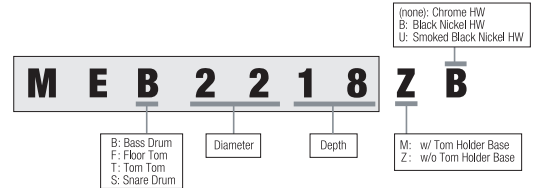

OPTION



Chrome HW



Black Nickel HW



Smoked Black Nickel HW

FINISHES (Lacquer)



Gloss Natural Movingui
VGLM

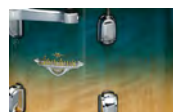

Ocean Blue Fade Movingui
VOLM

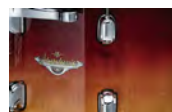

Violet Fade Movingui
VVLM



Rubiy Pacific Walnut Burst
LRWB



Emerald Pacific Walnut Burst
LEWB



Natural Pacific Walnut Burst
LNWB

STARCLASSIC MAPLE

Lacquer Finishes



COLOR Flat Steel Blue Metallic
w/ smoked black nickel hardware **FLM**

MA42TZUS basic kit

including:
16"x22" bass drum
7"x10" tom tom
8"x12" tom tom
16"x16" floor tom

[add-on]
6.5"x14" snare drum

KIT CONFIGURATIONS LIST

[20"BD 3pc Shell Kit]

MA30CMS w/Chrome Hardware
MA30CBNS w/Black Nickel Hardware
MA30CMUS w/Smoked Black Nickel Hardware

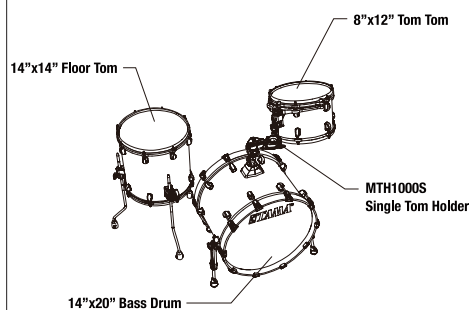

[22"BD 3pc Shell Kit]

MA32CZS w/Chrome Hardware
MA32CBNS w/Black Nickel Hardware
MA32CZUS w/Smoked Black Nickel Hardware

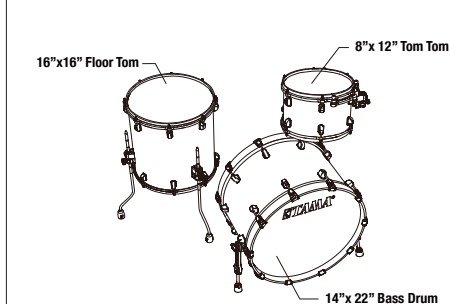

[22"BD 4pc Shell Kit]

MA42TZS w/Chrome Hardware
MA42ZBNS w/Black Nickel Hardware
MA42TZUS w/Smoked Black Nickel Hardware

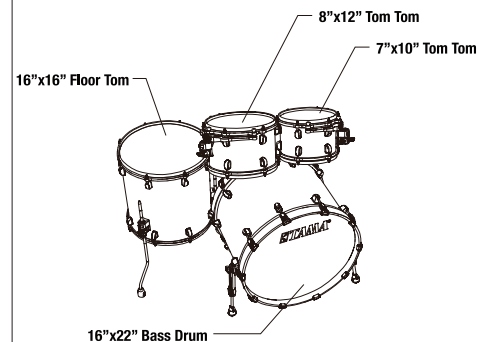

INDIVIDUAL MODEL NUMBERS

Diameter	Depth	Model No.		
		Black Nickel	Chrome	Smoked Black Nickel
Bass Drums				
*To order Bass Drum w/ Tom Holder Base, Please substitute "Z" with "M". Ex MAB2218Z → MAB2218M				
18"	14"	MAB1814ZBN	MAB1814Z	MAB1814ZU
18"	16"	MAB1816ZBN	MAB1816Z	MAB1816ZU
20"	14"	MAB2014ZBN	MAB2014Z	MAB2014ZU
20"	16"	MAB2016ZBN	MAB2016Z	MAB2016ZU
20"	18"	MAB2018ZBN	MAB2018Z	MAB2018ZU
22"	14"	MAB2214ZBN	MAB2214Z	MAB2214ZU
22"	16"	MAB2216ZBN	MAB2216Z	MAB2216ZU
22"	18"	MAB2218ZBN	MAB2218Z	MAB2218ZU
22"	20"	MAB2220ZBN	MAB2220Z	MAB2220ZU
24"	14"	MAB2414ZBN	MAB2414Z	MAB2414ZU
24"	16"	MAB2416ZBN	MAB2416Z	MAB2416ZU
24"	18"	MAB2418ZBN	MAB2418Z	MAB2418ZU
Floor Toms				
14"	12"	MAF1412BN	MAF1412	MAF1412U
14"	14"	MAF1414BN	MAF1414	MAF1414U
16"	14"	MAF1614BN	MAF1614	MAF1614U
16"	16"	MAF1616BN	MAF1616	MAF1616U
18"	16"	MAF1816BN	MAF1816	MAF1816U
Tom Toms				
8"	6"	MAT0806BN	MAT0806	MAT0806U
8"	7"	MAT0807BN	MAT0807	MAT0807U
8"	8"	MAT0808BN	MAT0808	MAT0808U
10"	6.5"	MAT1065BN	MAT1065	MAT1065U
10"	7"	MAT1007BN	MAT1007	MAT1007U
10"	8"	MAT1008BN	MAT1008	MAT1008U
10"	9"	MAT1009BN	MAT1009	MAT1009U
12"	7"	MAT1207BN	MAT1207	MAT1207U
12"	8"	MAT1208BN	MAT1208	MAT1208U
12"	9"	MAT1209BN	MAT1209	MAT1209U
12"	10"	MAT1210BN	MAT1210	MAT1210U
13"	7.5"	MAT1375BN	MAT1375	MAT1375U
13"	9"	MAT1309BN	MAT1309	MAT1309U
13"	10"	MAT1310BN	MAT1310	MAT1310U
13"	11"	MAT1311BN	MAT1311	MAT1311U
14"	10"	MAT1410BN	MAT1410	MAT1410U
14"	11"	MAT1411BN	MAT1411	MAT1411U
14"	12"	MAT1412BN	MAT1412	MAT1412U
16"	13"	MAT1613BN	MAT1613	MAT1613U
16"	14"	MAT1614BN	MAT1614	MAT1614U
Snare Drums				
13"	6"	MAS136BN	MAS136	MAS136U
14"	5.5"	MAS1455BN	MAS1455	MAS1455U
14"	6.5"	MAS1465BN	MAS1465	MAS1465U
14"	8"	MAS148BN	MAS148	MAS148U

SPECIFICATIONS

Shells

All Maple Shell
TT/FT: 5mm 6ply
BD/SD: 7mm 8ply

Star-Cast Mounting System

Quick-Lock Tom Brackets

EVANS® Heads

Die-Cast Hoops

Hold Tight™ Washers

Claw Hooks w/ Rubber Spacers

Cushioned Floor Tom Legs

MODEL NUMBER SYSTEM - Individual Drums

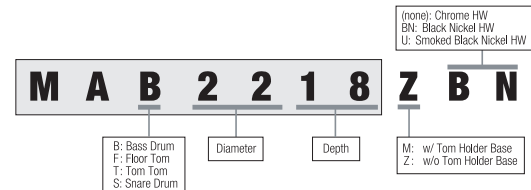

OPTION



Chrome HW



Black Nickel HW



Smoked Black Nickel HW

FINISHES (Lacquer)



Champagne Sparkle
CHS



Deeper Purple
DPP



Galaxy Chameleon Sparkle
GCS

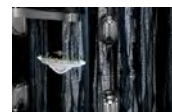

Black Clouds & Silver Linings
BCS



Light Jade Burst
LJB

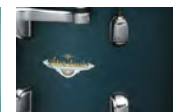

Flat Deep Green Metallic
FDG

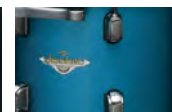

Flat Steel Blue Metallic
FLM



Satin Aztec Gold Metallic
SAM

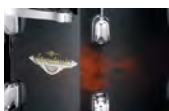

Dark Mocha Burst
DMB

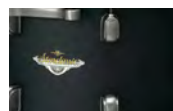

Flat Black
FBK

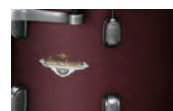

Flat Burgundy Metallic
FBM



Molten Satin Brown Burst
MBB



Vintage Antique Maple
VAM



Silver Snow Racing Stripe
SSR



Piano White
PWH



Piano Black
PBK

STARCLASSIC MAPLE

Duracover Wrap Finishes

NEW

COLOR Red and White Oyster
w/ chrome hardware **RWO**

MR32CZS basic kit

including:
14"x22" bass drum
8"x12" tom tom
16"x16" floor tom

[add-on]
6.5"x14" snare drum



KIT CONFIGURATIONS LIST

[20"BD 3pc Shell Kit]

MR30CMS w/Chrome Hardware
MR30CMBNS w/Black Nickel Hardware
MR30CMUS w/Smoked Black Nickel Hardware

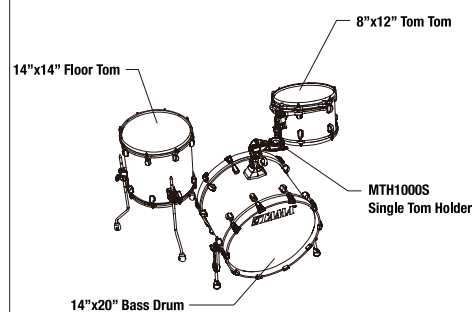

[22"BD 3pc Shell Kit]

MR32CZS w/Chrome Hardware
MR32CZBNS w/Black Nickel Hardware
MR32CZUS w/Smoked Black Nickel Hardware

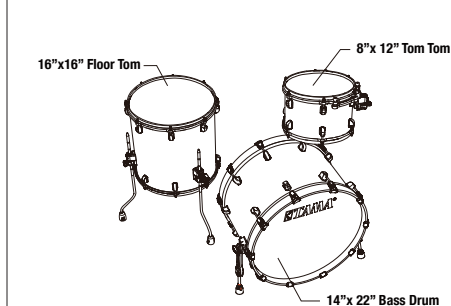

[22"BD 4pc Shell Kit]

MR42TZS w/Chrome Hardware
MR42ZBNS w/Black Nickel Hardware
MR42TZUS w/Smoked Black Nickel Hardware

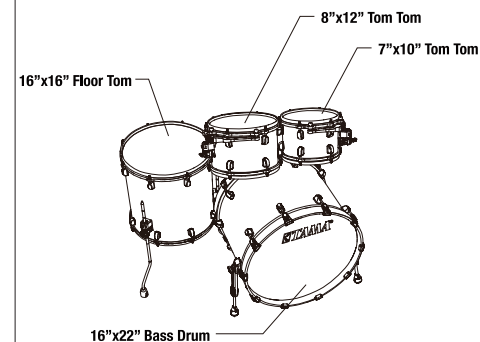

INDIVIDUAL MODEL NUMBERS

Diameter	Depth	Model No.		
		Black Nickel	Chrome	Smoked Black Nickel
Bass Drums				
*To order Bass Drum w/ Tom Holder Base, Please substitute "Z" with "M". Ex MRB2218Z → MRB2218M				
18"	14"	MRB1814ZBN	MRB1814Z	MRB1814ZU
18"	16"	MRB1816ZBN	MRB1816Z	MRB1816ZU
20"	14"	MRB2014ZBN	MRB2014Z	MRB2014ZU
20"	16"	MRB2016ZBN	MRB2016Z	MRB2016ZU
20"	18"	MRB2018ZBN	MRB2018Z	MRB2018ZU
22"	14"	MRB2214ZBN	MRB2214Z	MRB2214ZU
22"	16"	MRB2216ZBN	MRB2216Z	MRB2216ZU
22"	18"	MRB2218ZBN	MRB2218Z	MRB2218ZU
22"	20"	MRB2220ZBN	MRB2220Z	MRB2220ZU
24"	14"	MRB2414ZBN	MRB2414Z	MRB2414ZU
24"	16"	MRB2416ZBN	MRB2416Z	MRB2416ZU
24"	18"	MRB2418ZBN	MRB2418Z	MRB2418ZU
Floor Toms				
14"	12"	MRF1412BN	MRF1412	MRF1412U
14"	14"	MRF1414BN	MRF1414	MRF1414U
16"	14"	MRF1614BN	MRF1614	MRF1614U
16"	16"	MRF1616BN	MRF1616	MRF1616U
18"	16"	MRF1816BN	MRF1816	MRF1816U
Tom Toms				
8"	6"	MRT0806BN	MRT0806	MRT0806U
8"	7"	MRT0807BN	MRT0807	MRT0807U
8"	8"	MRT0808BN	MRT0808	MRT0808U
10"	6.5"	MRT1065BN	MRT1065	MRT1065U
10"	7"	MRT1007BN	MRT1007	MRT1007U
10"	8"	MRT1008BN	MRT1008	MRT1008U
10"	9"	MRT1009BN	MRT1009	MRT1009U
12"	7"	MRT1207BN	MRT1207	MRT1207U
12"	8"	MRT1208BN	MRT1208	MRT1208U
12"	9"	MRT1209BN	MRT1209	MRT1209U
12"	10"	MRT1210BN	MRT1210	MRT1210U
13"	7.5"	MRT1375BN	MRT1375	MRT1375U
13"	9"	MRT1309BN	MRT1309	MRT1309U
13"	10"	MRT1310BN	MRT1310	MRT1310U
13"	11"	MRT1311BN	MRT1311	MRT1311U
14"	10"	MRT1410BN	MRT1410	MRT1410U
14"	11"	MRT1411BN	MRT1411	MRT1411U
14"	12"	MRT1412BN	MRT1412	MRT1412U
16"	13"	MRT1613BN	MRT1613	MRT1613U
16"	14"	MRT1614BN	MRT1614	MRT1614U
Snare Drums				
13"	6"	MRS136BN	MRS136	MRS136U
14"	5.5"	MRS1455BN	MRS1455	MRS1455U
14"	6.5"	MRS1465BN	MRS1465	MRS1465U
14"	8"	MRS148BN	MRS148	MRS148U

SPECIFICATIONS

Shells

All Maple Shell
TT/FT: 5mm 6ply
BD/SD: 7mm 8ply

Star-Cast Mounting System

Quick-Lock Tom Brackets

EVANS® Heads

Die-Cast Hoops

Hold Tight™ Washers

Claw Hooks w/ Rubber Spacers

Cushioned Floor Tom Legs

MODEL NUMBER SYSTEM - Individual Drums

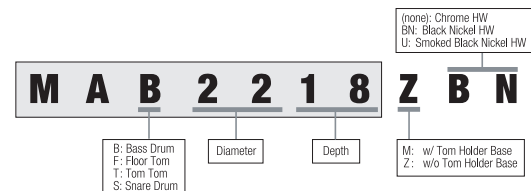

OPTION



Chrome HW



Black Nickel HW



Smoked Black Nickel HW

FINISHES (Duracover Wrap)



Red and White Oyster
RWO

NEW



Charcoal Swirl
CCL

NEW



Vintage Blue Sparkle
VBL

NEW



Red Oyster
ROY

NEW



Jade Silk
JDL

NEW



Charcoal Onyx
CCO

NEW



Ice Blue Pearl
IBP

NEW

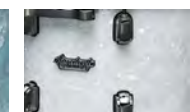

Snow White Pearl
SWP

NEW



Vintage Marine Pearl
VMP

NEW

STARCLASSIC WALNUT/BIRCH

Lacquer Finishes

Exploring limitless possibilities, our result in the wake of countless experimentation came in the form of the Hybrid Shell Walnut/Birch: combining the superior quality warmth and mid to low frequency tone of the increasingly popular and truly unique Walnut, with the well-defined and uncompromisingly solid attack of Birch.

Whilst we successfully preserved their unique sonic trademarks, the characteristics of both Walnut and Birch blend to persuade a very focused sound that would define itself with great distinction within a musical ensemble; married with controlled sustain and clarity; all sealed with an undeniably palpable feeling of warmth and resonance when performed.

NEW

COLOR Lacquer Phantasm Oyster LPO

WBS52RZS basic kit

including:
 16"x22" bass drum
 7"x10" tom tom
 8"x12" tom tom
 12"x14" floor tom
 14"x16" floor tom
 MC69 single tom attachments (x2)

[add-on]
 6.5"x14" snare drum



KIT CONFIGURATIONS LIST

[22"BD 3pc Shell Kit]

WBS32RZS w/Chrome Hardware

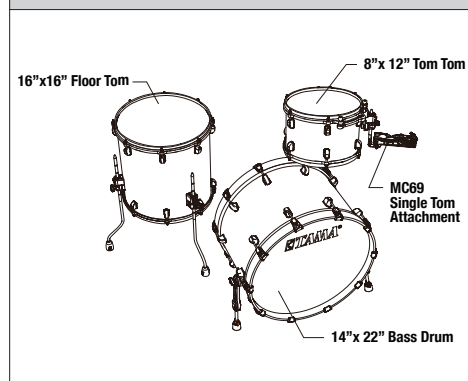

[22"BD 4pc Shell Kit]

WBS42S w/Chrome Hardware

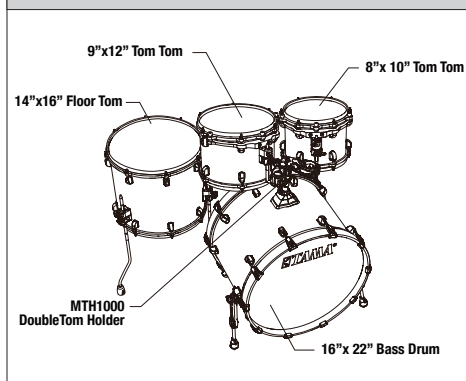

[22"BD 5pc Shell Kit]

WBS52RZS w/Chrome Hardware

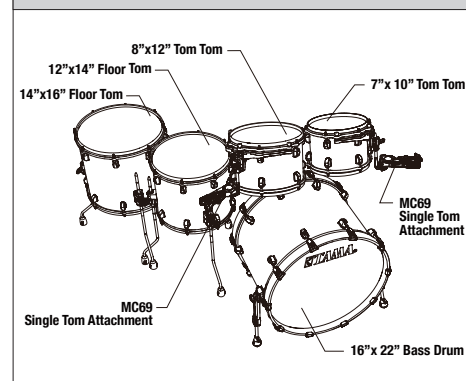

INDIVIDUAL MODEL NUMBERS

Diameter	Depth	Model No.
Bass Drums *To order Bass Drum w/ Tom Holder Base, Please substitute 'Z' with 'M'. Ex WBSB22DZ → WBSB22DM		
18"	14"	WBSB18RZ
20"	14"	WBSB20RZ
20"	16"	WBSB20DZ
20"	18"	WBSB20EZ
22"	14"	WBSB22RZ
22"	16"	WBSB22DZ
22"	18"	WBSB22EZ
22"	20"	WBSB22XZ
24"	16"	WBSB24DZ
24"	18"	WBSB24EZ
Floor Toms		
14"	12"	WBSF14A
14"	14"	WBSF14D
16"	14"	WBSF16A
16"	16"	WBSF16D
18"	16"	WBSF18D
Tom Toms		
8"	6"	WBST8H
8"	7"	WBST8A
10"	6.5"	WBST10H
10"	7"	WBST10R
10"	8"	WBST10A
12"	7"	WBST12H
12"	8"	WBST12R
12"	9"	WBST12A
13"	7.5"	WBST13H
13"	9"	WBST13R
13"	10"	WBST13A
14"	11"	WBST14A
14"	12"	WBST14D
16"	13"	WBST16A
16"	14"	WBST16D
Snare Drums		
13"	6"	WBSS136
14"	5.5"	WBSS55
14"	6.5"	WBSS65
14"	8"	WBSS148

MODEL NUMBER SYSTEM - Individual Drums

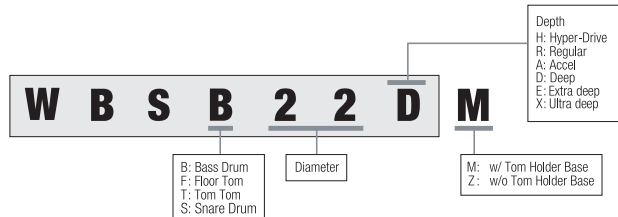

SPECIFICATIONS

Shells

TT/FT/SD: 6mm 4ply European Birch + 2 inner ply American Black Walnut
BD: 8mm 5ply European Birch + 2 inner ply American Black Walnut

Star-Cast Mounting System Claw Hooks w/ Rubber Spacers
Quick-Lock Tom Brackets Cushioned Floor Tom Legs
EVANS® Heads
Die-Cast Hoops

FINISHES (Lacquer)

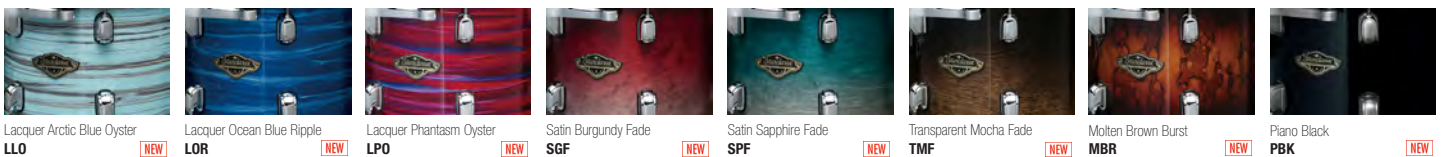

STARCLASSIC WALNUT/BIRCH

Duracover Wrap Finishes

NEW

COLOR Jade Silk **JDL**

WBR52S basic kit

including:
 16"x22" bass drum
 7"x10" tom tom
 8"x12" tom tom
 12"x14" floor tom
 14"x16" floor tom
 MTH1000 double tom holder

[add-on]
 6.5"x14" snare drum



KIT CONFIGURATIONS LIST

[22"BD 3pc Shell Kit]

WBR32RZS w/Chrome Hardware

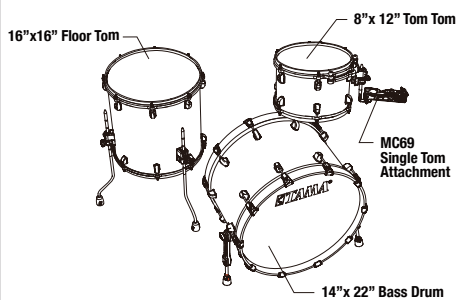

[22"BD 4pc Shell Kit]

WBR42S w/Chrome Hardware

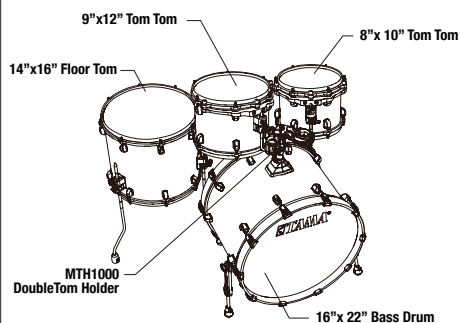

[22"BD 5pc Shell Kit]

WBR52RZS w/Chrome Hardware

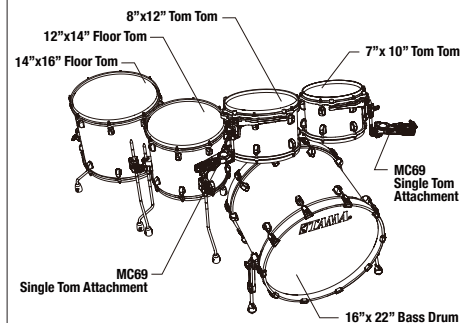

INDIVIDUAL MODEL NUMBERS

Diameter	Depth	Model No.
Bass Drums *To order Bass Drum w/ Tom Holder Base, Please substitute "Z" with "M". Ex WBRB22DZ → WBRB22DM		
18"	14"	WBRB18RZ
20"	14"	WBRB20RZ
20"	16"	WBRB20DZ
20"	18"	WBRB20EZ
22"	14"	WBRB22RZ
22"	16"	WBRB22DZ
22"	18"	WBRB22EZ
22"	20"	WBRB22XZ
24"	16"	WBRB24DZ
24"	18"	WBRB24EZ
Floor Toms		
14"	12"	WBRF14A
14"	14"	WBRF14D
16"	14"	WBRF16A
16"	16"	WBRF16D
18"	16"	WBRF18D
Tom Toms		
8"	6"	WBRT8H
8"	7"	WBRT8A
10"	6.5"	WBRT10H
10"	7"	WBRT10R
10"	8"	WBRT10A
12"	7"	WBRT12H
12"	8"	WBRT12R
12"	9"	WBRT12A
13"	7.5"	WBRT13H
13"	9"	WBRT13R
13"	10"	WBRT13A
14"	11"	WBRT14A
14"	12"	WBRT14D
16"	13"	WBRT16A
16"	14"	WBRT16D
Snare Drums		
13"	6"	WBRS136
14"	5.5"	WBRS55
14"	6.5"	WBRS65
14"	8"	WBRS148

MODEL NUMBER SYSTEM - Individual Drums

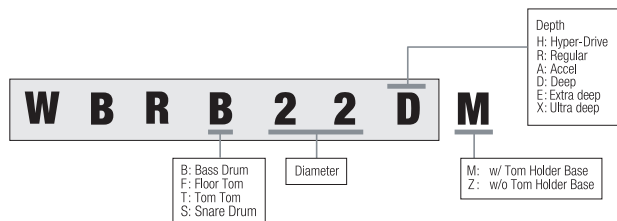

SPECIFICATIONS

Shells

TT/FT/SD: 6mm 4ply European Birch + 2 inner ply American Black Walnut
BD: 8mm 5ply European Birch + 2 inner ply American Black Walnut

Star-Cast Mounting System Claw Hooks w/ Rubber Spacers
Quick-Lock Tom Brackets Cushioned Floor Tom Legs
EVANS® Heads
Die-Cast Hoops

FINISHES (Duracover Wrap)



Jade Silk
JDL

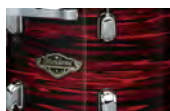

Red Oyster
ROY



Ice Blue Pearl
IBP



Vintage Marine Pearl
VMP



Charcoal Onyx
CCO

S.L.P. DRUM KITS -STUDIO MAPLE-

Lacquer Finish

The Studio Maple kit is very original model in both sound and appearance, with Sound Focus Rings on the inside of the shells and 100% Maple Wood Hoops. It has a focused, warm, woody tone with clear attack, and a relatively short sustain with beautiful decay. While great for live performance, this model really excels in the studio, especially when seeking a warm sound with controlled resonance.



COLOR Gloss Sienna **GSE**

LMP52RTLS basic kit

including:
 16"x22" bass drum
 7"x10" tom tom
 8"x12" tom tom
 14"x14" floor tom
 16"x16" floor tom
 MTH1000 double tom holder

[add-on]
 LMP1465F-SEN 6.5"x14" snare drum

KIT CONFIGURATIONS LIST

[22"BD 4pc Shell Kit]

LMP42RTLS

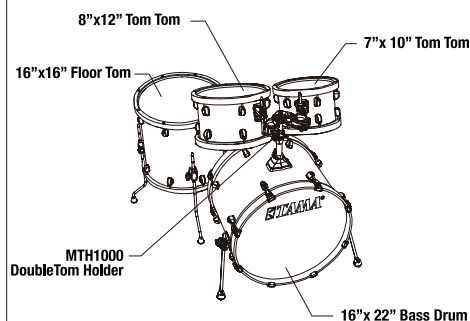

[22"BD 5pc Shell Kit]

LMP52RTLS

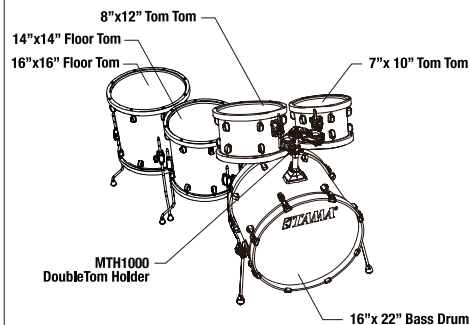

SPECIFICATIONS

Shells

All Maple Shell w/Sound Focus Ring
 TT/FT: 5mm 6ply , BD: 7mm 8ply

Maple Wood Hoops
 Direct Flexi-Mount
 EVANS® G1 Coated Heads

INDIVIDUAL MODEL NUMBERS

Diameter	Depth	Model No.
Floor Tom		
14"	14"	LMPF14D

FINISHES (Lacquer)



Gloss Sienna
 GSE



S.L.P. DRUM KITS -FAT SPRUCE-

Lacquer Finish

The Fat Spruce kit features luxurious 100% Spruce shells, which is rarely used as a material on complete drum sets. Its unique sound is fat and open with solid mids and a natural, acoustic vibe not found in more common materials. Furthermore, by utilizing die-cast hoops, it provides a very clear, focused sound.

This kit is also very versatile with a wide tuning range – can go low to medium, optimal for R&B, Blues, and Ballads, or tuned higher to work really well for Jazz and Indie Rock.



COLOR Satin Wild Spruce

TWS

LSP30CS basic kit

including:
 14"x20" bass drum
 8"x12" tom tom
 14"x14" floor tom
 MTH900BM single tom holder

[add-on]
 LSP146-WSS 6"x14" snare drum

SPECIFICATIONS

Shells

All Spruce Shell
 TT/FT: 6mm 6ply, BD: 8mm 8ply

Die-Cast Hoops
 Direct Flexi-Mount
 EVANS® G1 Coated Heads

KIT CONFIGURATIONS LIST

[20"BD 3pc Shell Kit]

LSP30CS

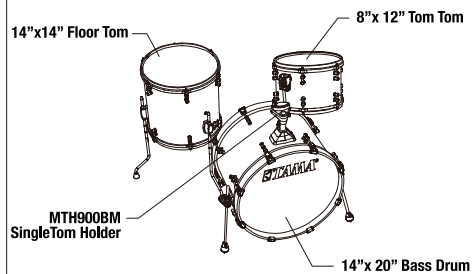

FINISHES (Lacquer)



Satin Wild Spruce
TWS



TAMA®

S.L.P.
SERIES
TAMA

S.L.P.
SERIES
TAMA

S.L.P. DRUM KITS -DYNAMIC KAPUR-

Lacquer Finish

This model features Kapur material, which has caught many drummers' attention for its solid, focused sound and rich mid- to low-end. We paired it with our Sound Arc Hoops for plenty of attack and moderately controlled overtones of the Kapur shells. It offers warm resonance and a very natural, comfortable feel. Because of its slightly dry sound and enhanced attack, it works very well for funk, fusion and gospel. The high volume potential also lends itself perfectly to rock music.

COLOR Gloss Black Kapur Burst **GKP**

LKP52HTS basic kit

including:
 16"x22" bass drum
 6.5"x10" tom tom
 7"x12" tom tom
 12"x14" floor tom
 14"x16" floor tom
 MTH905N double tom holder

[add-on]
 LKP1465-KPB 6.5"x14" snare drum



KIT CONFIGURATIONS LIST

[22"BD 4pc Shell Kit]

LKP42HTS

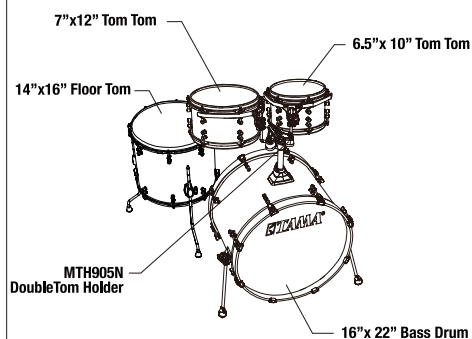

[22"BD 5pc Shell Kit]

LKP52HTS

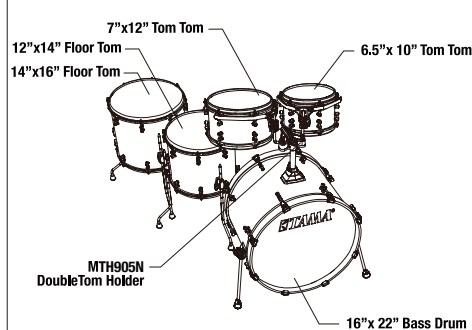

SPECIFICATIONS

Shells

All Kapur Shell
 TT/FT: 6mm 6ply, BD: 7mm 7ply

Sound Arc Hoop
 Star-Mount System
 Hyper-Drive Toms

INDIVIDUAL MODEL NUMBERS

Diameter	Depth	Model No.
Floor Tom		
14"	12"	LKPF14A

FINISHES (Lacquer)



Gloss Black Kapur Burst
GKP



TAMA®

Star-Mount
#TAMA

S.L.P.
SOUND LAB PROJECTS
#TAMA

S.L.P.
SOUND LAB PROJECTS
#TAMA

SUPERSTAR HYPER-DRIVE DUO

Lacquer Finishes

Superstar Hyper-Drive Duo is a unique and exciting series which will bring new value to the current drumming world. Similar to the groundbreaking work we did with the Superstar Hyper-Drive's extra shallow toms in 2008 - drawing inspiration drawn from recent performances of cutting-edge drummers - we have once again created distinct drum setups which are poised to inspire drummers. Opening the door to new approaches to drumming beyond the standard. The key component of this series is the 9" x 14" snare drum, which we call the "Duo Snare". This drum is unique not only because of its uncommon 9" depth, but also because it is equipped with floor tom legs and brackets. You can tune this drum low and place it where the first floor tom would traditionally go. As such, the snare can function as a low/deep snare with the snare wires engaged, or as a 14" floor tom with the snares off. This can lead to many unique phrasing opportunities. Once you experience playing on this new kit your eyes and ears will be opened to the infinite range of possibilities, plus it's a lot of fun. Just try it.

COLOR Flat Black Vertical Stripe **FBV**

ML52HZBN2 5pc basic kit

including:

- 16"x22" bass drum
- 6.5"x10" tom tom
- 7"x12" tom tom
- 14"x16" floor tom
- 10"x14" duo snare
- MC69 single tom attachments (x2)

[add-on]

LGW1465-MBW 6.5"x14" snare drum



INDIVIDUAL MODEL NUMBERS

Diameter	Depth	Model No.
Bass Drums		
20"	16"	MLB20DZBN
22"	16"	MLB22DZBN
Floor Toms		
14"	12"	MLF14ALBN
16"	14"	MLF16ALBN
18"	16"	MLF18DLBN
Tom Toms		
8"	6"	MLT8HBN
10"	6.5"	MLT10HBN
12"	7"	MLT12HBN
13"	7.5"	MLT13HBN
14"	8"	MLT14HBN
Snare Drums		
13"	6"	MLS136BN
14"	5.5"	MLS55BN
14"	6.5"	MLS65BN
Duo Snare Drum		
14"	10"	MLS1410LBN

SPECIFICATIONS

Shells

All Maple
TT/FT/SD: 5mm 6ply, BD: 7mm 8ply

Star-Cast Mounting System
Duo Snare
Die-Cast Hoops
EVANS® Power Center Reverse
Dot for Duo Snare
Power Craft II Drum Heads

KIT CONFIGURATIONS LIST

[20"BD 4pc Shell Kit]

ML40HZBN2
ML40HZBN2H w/ HBSW hardware pack

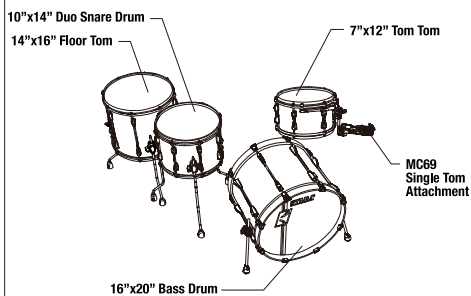

[22"BD 5pc Shell Kit]

ML52HZBN2
ML52HZBN2H w/ HBSW hardware pack

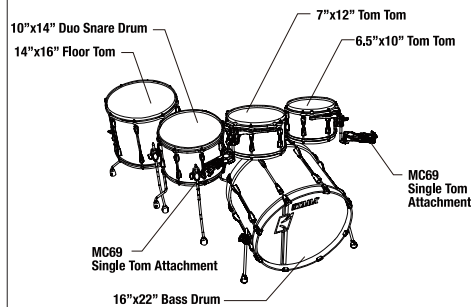

FINISHES (Lacquer)



Satin Blue Vertical Stripe
SBV



Satin Silver Vertical Stripe
SSV



Flat Black Vertical Stripe
FBV

SUPERSTAR HYPER-DRIVE MAPLE

Lacquer Finishes

Power. Flexibility. Visibility. With TAMA Hyper-Drive kits, your audience will hear your every note and see your every move. Hyper-Drive's unique combination of modern and traditional drum sizes offers sonic power with clarity, unparalleled set-up flexibility, and complete performance visibility.

COLOR	Satin Arctic Pearl	SAP
--------------	--------------------	------------

ML52HLZBNS 5pc basic kit

including:
18"x22" bass drum
6.5"x10" tom tom
7"x12" tom tom
12"x14" floor tom
14"x16" floor tom
MC69 single tom attachments (x2)

[add-on]
5.5"x14" snare drum



INDIVIDUAL MODEL NUMBERS

Diameter	Depth	Model No.
Bass Drums		
22"	18"	MLB22EZBN
22"	20"	MLB22XZBN
24"	18"	MLB24EZBN
Floor Toms		
14"	12"	MLF14ABN
16"	14"	MLF16ABN
18"	16"	MLF18DBN
Tom Toms		
8"	6"	MLT8HBN
10"	6.5"	MLT10HBN
12"	7"	MLT12HBN
13"	7.5"	MLT13HBN
14"	8"	MLT14HBN
Snare Drums		
13"	6"	MLS136BN
14"	5.5"	MLS55BN
14"	6.5"	MLS65BN

SPECIFICATIONS

Shells

All Maple
TT/FT/SD: 5mm 6ply, BD: 7mm 8ply

Star-Cast Mounting System
Hyper-Drive Toms
Die-Cast Hoops
Power Craft II Drum Heads

KIT CONFIGURATIONS LIST

[22"BD 4pc Shell Kit]

ML42HLZBNS
ML42HLZBN w/ HBSW hardware pack

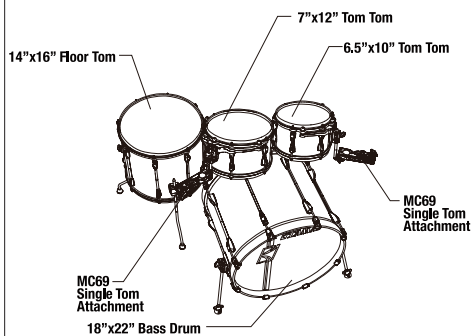

[22"BD 5pc Shell Kit]

ML52HLZBNS
ML52HLZBN w/ HBSW hardware pack

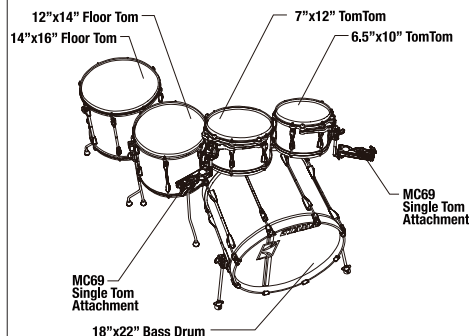

FINISHES (Lacquer)



Golden Yellow Metallic
GYM



Vintage Blue Metallic
VBM



Dark Mocha Fade
DMF



Flat Black
FBK



Satin Arctic Pearl
SAP



Classic Cherry Wine
CCW

SUPERSTAR HYPER-DRIVE MAPLE

Unicolor Wrap Finishes

COLOR Midnight Gold Sparkle **MGD**

MK52HLZBNS 5pc basic kit

including:

18"x22" bass drum
6.5"x10" tom tom
7"x12" tom tom
12"x14" floor tom
14"x16" floor tom
MC69 single tom attachments (x2)

[add-on]

5.5"x14" snare drum



INDIVIDUAL MODEL NUMBERS

Diameter	Depth	Model No.
Bass Drums		
22"	18"	MKB22EZBN
22"	20"	MKB22XZBN
24"	18"	MKB24EZBN
Floor Toms		
14"	12"	MKF14ABN
16"	14"	MKF16ABN
18"	16"	MKF18DBN
Tom Toms		
8"	6"	MKT8HBN
10"	6.5"	MKT10HBN
12"	7"	MKT12HBN
13"	7.5"	MKT13HBN
14"	8"	MKT14HBN
Snare Drums		
13"	6"	MKS136BN
14"	5.5"	MKS55BN
14"	6.5"	MKS65BN

SPECIFICATIONS

Shells

All Maple
TT/FT/SD: 5mm 6ply, BD: 7mm 8ply

Star-Cast Mounting System
Hyper-Drive Toms
Die-Cast Hoops
Power Craft II Drum Heads

KIT CONFIGURATIONS LIST

[22"BD 4pc Shell Kit]

MK42HLZBNS
MK42HLZBN w/ HBSW hardware pack

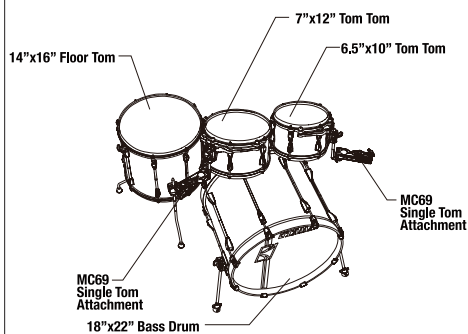

[22"BD 5pc Shell Kit]

MK52HLZBNS
MK52HLZBN w/ HBSW hardware pack

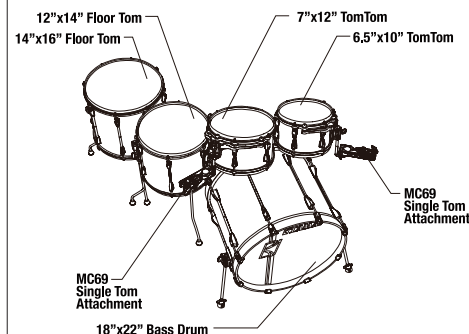

FINISHES (Unicolor Wrap)



Bright Orange Sparkle
BOS



Midnight Gold Sparkle
MGD



Indigo Sparkle
ISP



Brushed Charcoal Black
BCB



Sugar White
SGW

SUPERSTAR CLASSIC MAPLE

Exotic Finishes

For more than forty years, the Superstar name has stood for groundbreaking design, superior build quality, sterling tone, and clear projection. Superstar Classic once again upholds tradition by raising the bar for discerning drummers—and remarkably—does it while also lowering the price. Drawing on Superstar of the past, its classic TAMA T-shape badge and streamlined low-mass single lugs point to the simpler state of art of the 70's, while the ingenious Star-Mount system and the thinner gauge 100% maple shells eclipse anything in its class.

NEW

COLOR Garnet Burst Lacebark Pine **PGBP**

CL72RS 7pc basic kit

including:
16"x22" bass drum
6"x8" tom tom
7"x10" tom tom
8"x12" tom tom
12"x14" floor tom
14"x16" floor tom
6.5"x14" snare drum
MTH600 double tom holder
MC69 single tom attachment



INDIVIDUAL MODEL NUMBERS

Diameter	Depth	Model No.
Bass Drums		
18"(w/ bass drum lifter)	14"	CLB18RL
20"	16"	CLB20D
22"	16"	CLB22D
24"	16"	CLB24D
Floor Toms		
14"	12"	CLF14A
14"	14"	CLF14D
16"	14"	CLF16A
18"	16"	CLF18D
Tom Toms		
8"	6"	CLT8H
10"	7"	CLT10R
12"	8"	CLT12R
13"	9"	CLT13R
Snare Drums		
14"	5"	CLS145
14"	6.5"	CLS1465

SPECIFICATIONS

Shells

TT/FT/SD: 5mm 4ply Maple + 2 outer ply Lacebark Pine
 BD: 7mm 6ply Maple + 2 outer ply Lacebark Pine

Star-Mount System
 Low-Mass Lugs
 Power Craft II Drum Heads

KIT CONFIGURATIONS LIST

[22"BD 7pc Shell Kit]

CL72RS
 CL72R w/SMSW hardware pack

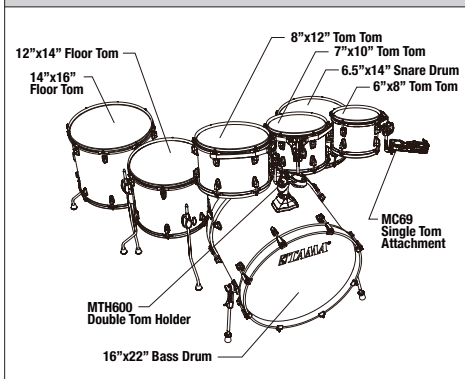

FINISHES (Lacquer)



Garnet Burst Lacebark Pine
PGBP

NEW

Java Burst Lacebark Pine
PJBP

NEW

Sapphire Burst Lacebark Pine
PSBP

NEW

SUPERSTAR CLASSIC MAPLE

Lacquer Finishes

NEW

COLOR Satin Artic Pearl **SAP**

CL52KRS 5pc basic kit

including:
16"x22" bass drum
7"x10" tom tom
8"x12" tom tom
14"x16" floor tom
6.5"x14" snare drum
MTH600 double tom holder



INDIVIDUAL MODEL NUMBERS

Diameter	Depth	Model No.
Bass Drums		
18"(w/ bass drum lifter)	14"	CLB18RL
20"	16"	CLB20D
22"	16"	CLB22D
24"	16"	CLB24D
Floor Toms		
14"	12"	CLF14A
14"	14"	CLF14D
16"	14"	CLF16A
18"	16"	CLF18D
Tom Toms		
8"	6"	CLT8H
10"	7"	CLT10R
12"	8"	CLT12R
13"	9"	CLT13R
Snare Drums		
14"	5"	CLS145
14"	6.5"	CLS1465

SPECIFICATIONS

Shells

All Maple Shell
 TT/FT/SD: 5mm 6ply
 BD: 7mm 8ply

Star-Mount System
 Low-Mass Lugs
 Power Craft II Drum Heads

KIT CONFIGURATIONS LIST

[18" BD 4pc Shell Kit]

CL48S
 CL48 w/ SMSW hardware pack

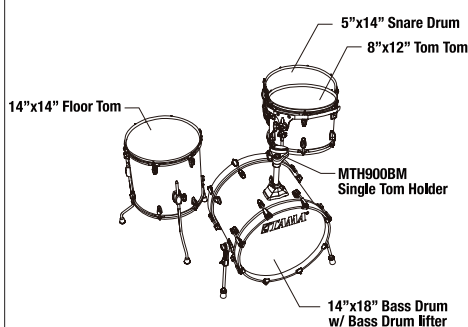

[20"BD 5pc Shell Kit]

CL50RS
 CL50R w/ SMSW hardware pack

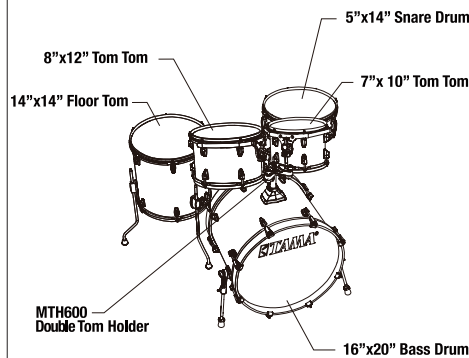

[22"BD 5pc Shell Kit]

CL52KRS
 CL52KR w/ SMSW hardware pack

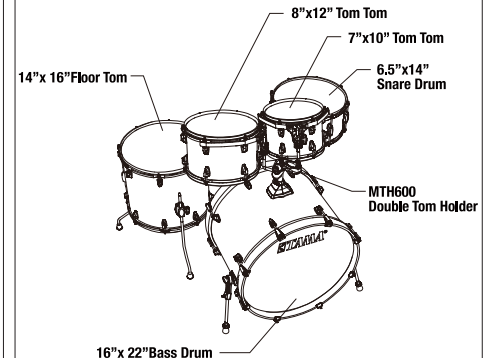

FINISHES (Lacquer)



Blue Lacquer Burst
BAB



Coffee Fade
CFF



Tangerine Lacquer Burst
TLB



Satin Arctic Pearl
SAP

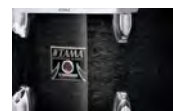

Transparent Black Burst
TPB NEW

SUPERSTAR CLASSIC MAPLE

Unicolor Wrap Finishes

NEW

COLOR Indigo Sparkle ISP

CK52KRS 5pc basic kit

including:
16"x22" bass drum
7"x10" tom tom
8"x12" tom tom
14"x16" floor tom
6.5"x14" snare drum
MTH600 double tom holder



INDIVIDUAL MODEL NUMBERS

Diameter	Depth	Model No.
Bass Drums		
18"(w/ bass drum lifter)	14"	CKB18RL
20"	16"	CKB20D
22"	16"	CKB22D
24"	16"	CKB24D
Floor Toms		
14"	12"	CKF14A
14"	14"	CKF14D
16"	14"	CKF16A
18"	16"	CKF18D
Tom Toms		
8"	6"	CKT8H
10"	7"	CKT10R
12"	8"	CKT12R
13"	9"	CKT13R
Snare Drums		
14"	5"	CKS145
14"	6.5"	CKS1465

SPECIFICATIONS

Shells

All Maple Shell
 TT/FT/SD: 5mm 6ply
 BD: 7mm 8ply

Star-Mount System
 Low-Mass Lugs
 Power Craft II Drum Heads

KIT CONFIGURATIONS LIST

[18" BD 4pc Shell Kit]

CK48S
CK48 w/ SMSW hardware pack

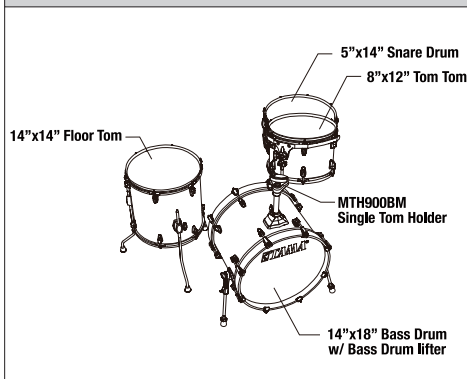

[20"BD 5pc Shell Kit]

CK50RS
CK50R w/ SMSW hardware pack

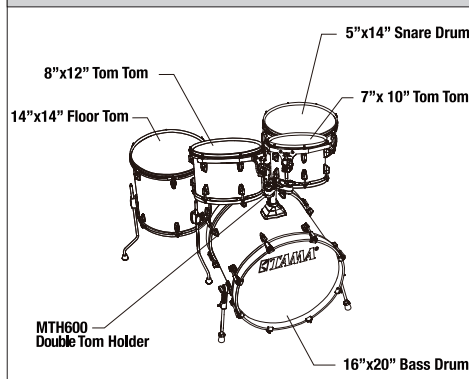

[22"BD 5pc Shell Kit]

CK52KRS
CK52KR w/ SMSW hardware pack

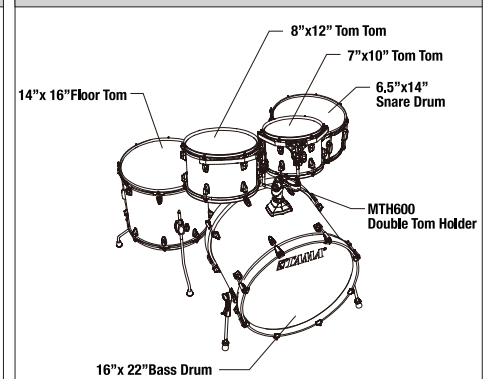

FINISHES (Unicolor Wrap)



Indigo Sparkle
ISP



Midnight Gold Sparkle
MGD



Dark Red Sparkle
DRP



Vintage White Sparkle
VWS

NEW

NEW

NEW

NEW

IMPERIALSTAR

Unicolor Wrap Finishes

With over 40 years of drum building experience, TAMA knows what drummers really want. With this in mind we sought out to design an affordable yet durable kit that retained many high-end features you'll find in our Superstar, and Starclassic lines. What we came up with was Imperialstar. Every aspect of the modern drum kit was exhaustively examined, reexamined, and then improved before it was accepted as part of the Imperialstar design.

NEW

COLOR Black Oak Wrap **BOW**

IE52KH6W 22" Bass Drum 5pc basic kit

Drums:

16"x22" bass drum, 7"x10" & 8"x12" tom toms, 15"x16" floor tom, 5"x14" snare drum.

Hardware:

double tom holder, hi-hat stand, drum pedal, snare stand, boom cymbal stand, straight cymbal stand, drum throne.

Including MEINL MCS Cymbal Set

14" Hihat, 16" Crash, 20" Ride



INDIVIDUAL MODEL NUMBERS

Diameter	Depth	Model No.
Bass Drums		
18"	14"	IEB18RW
20"	16"	IEB20DW
22"	16"	IEB22DW
Floor Toms		
14"	13"	IEF14R
16"	15"	IEF16R
18"	16"	IEF18D
Tom Toms		
8"	6.5"	IET8H
10"	7"	IET10R
12"	8"	IET12R
13"	9"	IET13R
Snare Drums		
14"	5"	IES145
14"	6.5"	IES1465

SPECIFICATIONS

Shells

All Poplar Shell: 8mm 6ply

Omnisphere Tom Holder
Wood Bass Drum Hoops
Double Braced Hardware

KIT CONFIGURATIONS LIST

[18"BD 5pc Kit w/ Hardware]

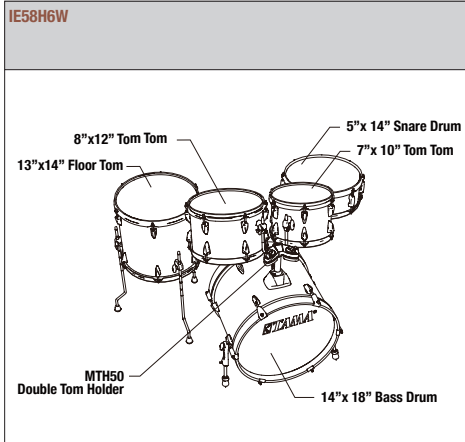

[20"BD 5pc Kit w/ Hardware]

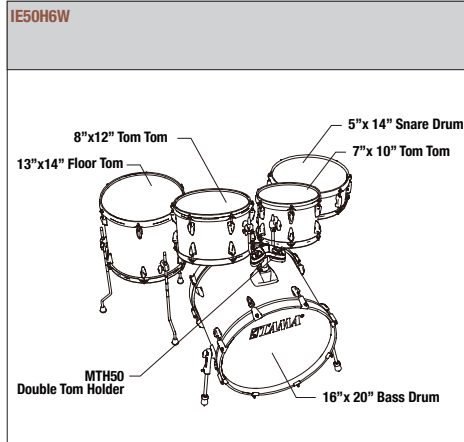

[22"BD 5pc Kit w/ Hardware]

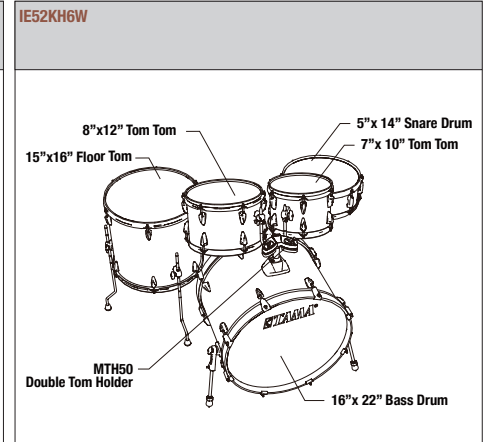

[22"BD 6pc Kit w/ Hardware]

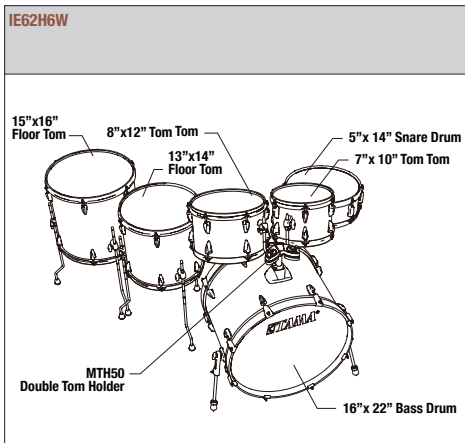

FINISHES (Unicolor Wrap)

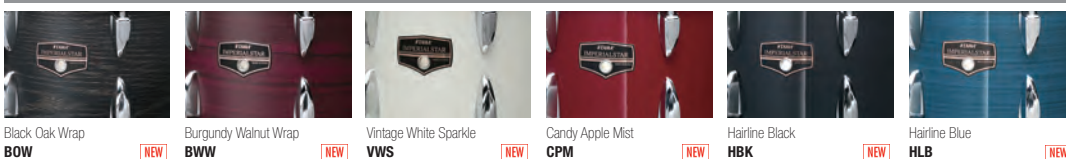

RHYTHM MATE

Unicolor Wrap Finishes

TAMA's entry-level Rhythm Mate drum kit provides the precise bearing edges for easy tuning that beginners need and the wide tuning range that pros demand. TAMA's original Accu-Tune Bass Drum Hoops offer faster, more consistent tuning than traditional metal hoops. And if that wasn't enough, the hardware is equipped with double-braced legs for increased stability. TAMA Rhythm Mate drums are changing the way entry-level kits are designed.



COLOR Red Stream **RDS**

RM52KH6 22" Bass Drum 5pc basic kit

Drums:
16"x22" bass drum, 7"x10" & 8"x12" tom toms, 15"x16" floor tom, 5"x14" snare drum.

Hardware:
double tom holder, hi-hat stand, drum pedal, snare stand, boom cymbal stand, straight cymbal stand, drum throne

Including MEINL BCS Cymbal Set

14" Hi-hat, 16" Crash, 20" Ride



Rhythm Mate all-in-one "READY-TO-ROCK" packages not only have everything you need to rock, you'll rock better with BCS genuine brass cymbals from Meinl®, the cymbal maker of choice for many of today's new generation drummers.



KIT CONFIGURATIONS LIST

[22"BD 5pc Kit w/ Hardware]

- RM52KH6
- RM52KH5 *w/o boom stand from RM52KH6
- RM52KH4 *w/o drum throne from RM52KH5

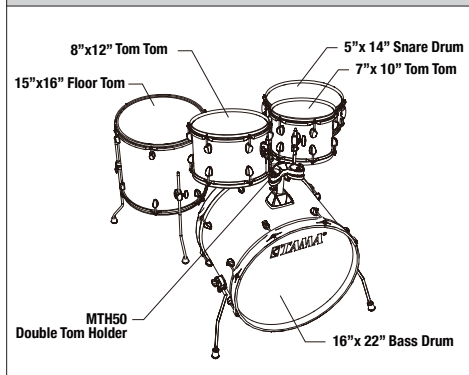

[20"BD 5pc Kit w/ Hardware]

- RM50YH6
- RM50YH5 *w/o boom stand from RM50YH6
- RM50YH4 *w/o drum throne from RM50YH5

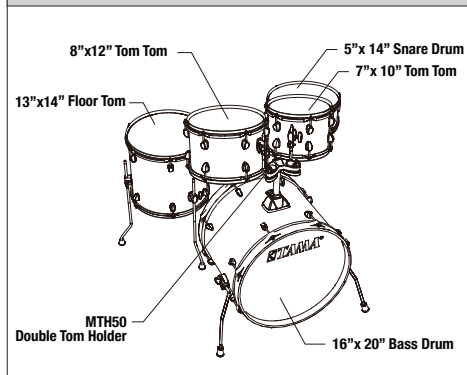

SPECIFICATIONS

Shells

All Poplar Shell: 8mm 9ply

- Omnisphere Tom Holder
- Accu-Tune Bass Drum Hoops
- Double Braced Hardware

FINISHES (Unicolor Wrap)



Red Stream
RDS



Galaxy Silver
GXS



Charcoal Mist
CCM



Hairline Blue
HLB



White
WH



Black
BK

CLUB-JAM

Lacquer Finish

The "Club-JAM" Kit adopts some ideas from vintage kits, such as a cymbal holder mounted directly on the bass drum shell and curved bass drum spurs, further setting it apart from the typical compact kit. Focused yet deep sound from Mersawa / Poplar hybrid shell is just right for small and intimate gigs. Its compact size and configuration make it ideal for working drummers, and it fits comfortably on just about any stage.



COLOR Satin Blonde **SBO**

LJL48S 18" Bass Drum 4pc basic kit

Drums:
12"x18" bass drum, 7"x10" tom tom, 7"x14" floor tom, 5"x13" snare drum.

Hardware:
single tom holder, cymbal holder.

LJL48H4 18" Bass Drum 4pc basic kit

Drums:
12"x18" bass drum, 7"x10" tom tom, 7"x14" floor tom, 5"x13" snare drum.

Hardware:
single tom holder, hi-hat stand, drum pedal, snare stand, cymbal holder, drum throne.

SPECIFICATIONS

Shells

8mm 3ply Poplar + 2 outer ply Mersawa + 2 inner ply Mersawa

Bass Drum Mounted Cymbal Holder
Bass Drum Wood Hoops
Compact Sizes for Easy Transport
DSS48LJ Bag Set Sold Separately

KIT CONFIGURATIONS LIST

[18"BD 4pc Shell Kit]

LJL48S
LJL48H4 w/ hardware

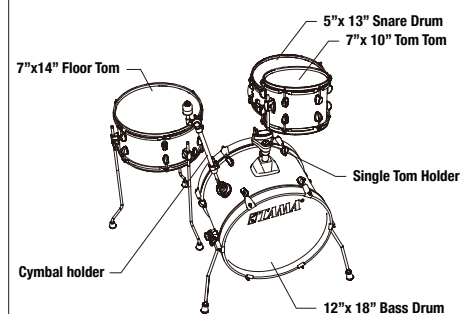

FINISHES (Lacquer)



Satin Blonde
SBO

CLUB-JAM

Unicolor Wrap Finishes



COLOR Charcoal Mist **CCM**

LJK48S 18" Bass Drum 4pc basic kit

Drums:
12"x18" bass drum, 7"x10" tom tom, 7"x14" floor tom, 5"x13" snare drum.

Hardware:
single tom holder, cymbal holder.

LJK48H4 18" Bass Drum 4pc basic kit

Drums:
12"x18" bass drum, 7"x10" tom tom, 7"x14" floor tom, 5"x13" snare drum.

Hardware:
single tom holder, hi-hat stand, drum pedal, snare stand, cymbal holder, drum throne.

SPECIFICATIONS

Shells

8mm 5ply Poplar + 2 inner ply Mersawa

Bass Drum Mounted Cymbal Holder
Bass Drum Wood Hoops
Compact Sizes for Easy Transport
DSS48LJ Bag Set Sold Separately

KIT CONFIGURATIONS LIST

[18"BD 4pc Shell Kit]

LJK48S
LJK48H4 w/ hardware

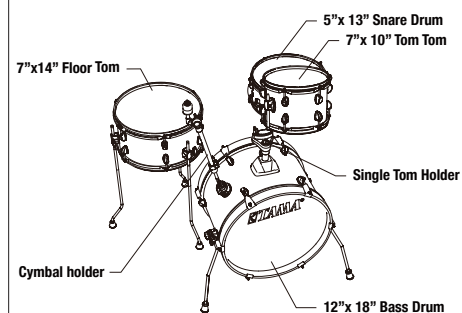

FINISHES (Unicolor Wrap)

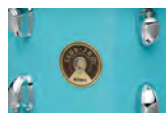

Aqua Blue
AQB



Charcoal Mist
CCM



Galaxy Silver
GXS

NEW

CLUB-JAM MINI

Unicolor Wrap Finishes

The simple and sweet TAMA Club-JAM Mini kit is just a kick and snare. Its clear yet deep sound from the Mersawa / Poplar hybrid shell is just right for those small and intimate gigs. While its compact size and configuration fit comfortably at any small venue or street show. The Drum Bag Set for this kit allows for smooth transportation (sold separately). If one needs to configure it as a regular drum kit, also available are add-on drums including the 7"x10" tom tom with attachment and a 7"x14" floor tom.

NEW



COLOR	Galaxy Silver	GXS
LJK28S 18" Bass Drum 2pc basic kit		
Drums: 7"x18" bass drum, 5"x12" snare drum.		
LJK28H4 18" Bass Drum 2pc basic kit		
Drums: 7"x18" bass drum, 5"x12" snare drum.		
Hardware: hi-hat stand, drum pedal, snare stand, drum throne.		
LJKT10F14 Add-on pack		
Drums: 7"x10" tom tom, 7"x14" floor tom		
Hardware: single tom attachment		

SPECIFICATIONS

Shells

8mm 6ply Poplar + 2 inner ply Mersawa

Bass Drum Wood Hoops

LJKT10F14 Add-on Kit sold separately
(6.5"x10" TT, 7"x14" FT, Single Tom Attachment)

DSS28LJ Bag Set Sold Separately

KIT CONFIGURATIONS LIST

[18"BD 2pc Shell Kit]

LJK28S
LJK28H4 w/ hardware

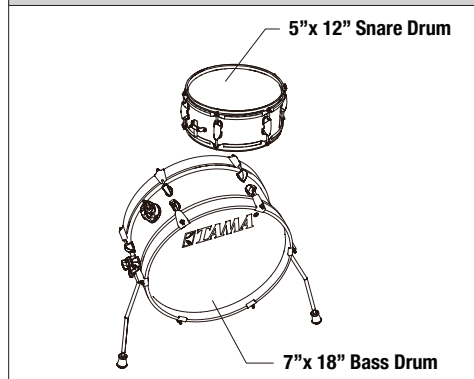

LJKT10F14

FINISHES (Unicolor Wrap)



Aqua Blue
AOB



NEW
Charcoal Mist
CCM



NEW
Galaxy Silver
GXS

NEW

COCKTAIL-JAM

Unicolor Wrap Finishes

The Cocktail-JAM Kit™ is a TAMA original in both appearance and sound. It's ideal for hip-hop, jazz, intimate acoustic settings, and tight rehearsal rooms. Completely compact, this kit can easily be set up and played using a throne in spaces much smaller than a typical drum set. Additionally, the Cocktail-JAM Kit and its hardware can be easily packed into just two bags (included with the kit), making it super portable and easy to transport to any gig. Have fun jamming with the Cocktail-JAM Kit!



COLOR Bright Orange Sparkle **BOS**

CJB46 basic kit

Drums:

6"x16" bass drum, 5"x10" tom tom, 5.5"x14" floor tom, 5"x12" snare drum, Sound Focus Pad, drum bag, hardware bag.

Hardware:

single tom attachments (x2), single pedal.

CJB46C basic kit w/ cymbal attachments

Drums:

6"x16" bass drum, 5"x10" tom tom, 5.5"x14" floor tom, 5"x12" snare drum, Sound Focus Pad, drum bag, hardware bag.

Hardware:

single tom attachments (x2), single pedal, cymbal attachment, hi-hat attachment

SPECIFICATIONS

Shells

All Birch Shells
TT/FT/SD: 6mm 6ply
BD: 8mm 7ply

Sound Focus Pad

Specially Designed Bags Included

KIT CONFIGURATIONS LIST

[16"BD 4pc Kit]

CJB46

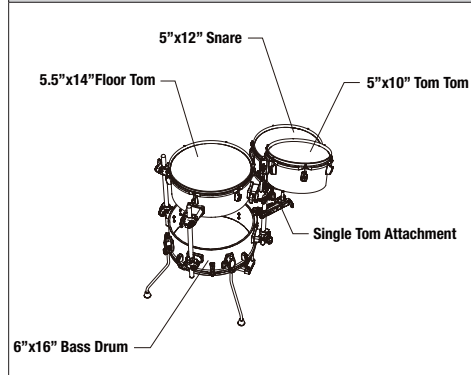

[16"BD 4pc Kit with clamp kit]

CJB46C

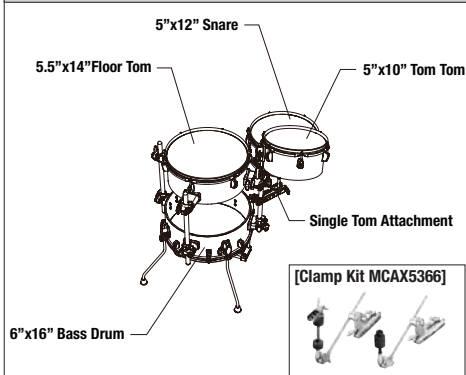

FINISHES (Unicolor Wrap)



Bright Orange Sparkle
BOS



Indigo Sparkle
ISP



Midnight Gold Sparkle
MGD

SNARE DRUMS

TAMA has a wide variety of snare drum options to complement our array of drum kits. From our super high end STAR snare drums to the METALWORKS series, which offers quality at a great price, there is a model to fit every drummer's desired sound and budget.

STAR BUBINGA



Color: Solid Candy Red -SDR

TBS1465S

MADE IN JAPAN

Please refer to the STAR Bubinga drum kit page to see available sizes, finishes, and inlay options.

Lug: MSL90S
Hoop: Die-Cast Hoop (8 hole)
Strainer/Butt: MLS50A/MLS50B
Snare Wire: 14"=MS20RL14C,
13"=MS20RL13C

STAR MAPLE



Color: Ocean Blue Curly Maple -ROLC

TMS1465S

MADE IN JAPAN

Please refer to the STAR Maple drum kit page to see available sizes, finishes, and inlay options.

Lug: MSL90S
Hoop: Die-Cast Hoop (8 hole)
Strainer/Butt: MLS50A/MLS50B
Snare Wire: 14"=MS20RL14C,
13"=MS20RL13C

STAR WALNUT



Color: Indigo Japanese Sen Burst -AJLB

TWS1465

MADE IN JAPAN

Please refer to the STAR Walnut drum kit page to see available sizes and finishes.

Lug: MSL90S
Hoop: Die-Cast Hoop (8 hole)
Strainer/Butt: MLS50A/MLS50B
Snare Wire: 14"=MS20RL14C,
13"=MS20RL13C

STAR SOLID MAPLE



Color: Oiled Natural Maple -OMP

TLM146S

MADE IN JAPAN

Shell: 8mm Solid Maple, w/ 8mm Sound Focus Rings
Size: 6"x14"
Lug: MSL90S
Hoop: Die-Cast Hoop (8 hole)
Strainer/Butt: MLS50A/MLS50B
Snare Wire: MS20RL14C
Color: Oiled Natural Maple (OMP)
[Inlay Option] Outside Inlay, or w/o Inlay

STAR SOLID ZEBRAWOOD



Color: Oiled Natural Zebrawood -OZW

TLZ146S

MADE IN JAPAN

Shell: 7mm Solid Zebrawood, w/ 7mm Sound Focus Rings
Size: 6"x14"
Lug: MSL90S
Hoop: Die-Cast Hoop (8 hole)
Strainer/Butt: MLS50A/MLS50B
Snare Wire: MS20RL14C
Color: Oiled Natural Zebrawood (OZW)
[Inlay Option] Outside Inlay, or w/o Inlay

STAR SOLID MAHOGANY



Color: Oiled Natural Mahogany -OMH

TLH146S

MADE IN JAPAN

Shell: 7mm Solid Mahogany w/ 7mm Sound Focus Rings
Size: 6"x14"
Lug: MSL90S
Hoop: Die-Cast Hoop (8 hole)
Strainer/Butt: MLS50A/MLS50B
Snare Wire: MS20RL14C
Color: Oiled Natural Mahogany (OMH)
[Inlay Option] Outside Inlay, or w/o Inlay

STAR STAVE WALNUT



Color: Oiled Natural Walnut -OWN

TVW146S

MADE IN JAPAN

Shell: 10mm, 16pcs Stave Walnut
Size: 6"x14"
Lug: MSL90S
Hoop: Die-Cast Hoop (8 hole)
Strainer/Butt: MLS50A/MLS50B
Snare Wire: MS20RL14C
Color: Oiled Natural Walnut (OWN)
[Inlay Option] Outside Inlay, or w/o Inlay

STAR STAVE ASH



Color: Oiled Natural Ash -OAS

TVA146S

MADE IN JAPAN

Shell: 10mm, 16pcs Stave Ash
Size: 6"x14"
Lug: MSL90S
Hoop: Die-Cast Hoop (8 hole)
Strainer/Butt: MLS50A/MLS50B
Snare Wire: MS20RL14C
Color: Oiled Natural Ash (OAS)
[Inlay Option] Outside Inlay, or w/o Inlay

STAR RESERVE SOLID MAPLE



Color: Oiled Natural Maple -OMP

TLM145S

MADE IN JAPAN

Shell: 8mm Solid Maple w/ 8mm Solid Maple Sound Focus Rings
Size: 5"x14"
Lug: MTL150
Hoop: 2.3mm Brass Sound Arc Hoop (8 hole)
Strainer/Butt: MLS50A / MLS50B
Snare Wire: MS20L14C8
Color: Oiled Natural Maple (OMP)

STAR RESERVE BUBINGA/MAPLE



Color: Caramel Olive Ash Burst -OCOB

TMBS158S

MADE IN JAPAN

Shell: 5.5mm, 8ply Bubinga/Maple (1 inner ply Cordia+2ply Bubinga+4ply Maple+1outer ply Olive Ash)
Size: 8"x15"
Lug: MSL90T
Hoop: Brass Mighty Hoop (8 hole)
Strainer/Butt: MLS50A / MLS50B
Snare Wire: MS20SN15S
Color: Caramel Olive Ash Burst (OCOB)

STAR RESERVE WALNUT/BUBINGA



Color: Gloss Claro Walnut -GCW

TBWS1465S

MADE IN JAPAN

Shell: 5.5mm, 7ply Walnut / Bubinga (4ply Walnut + 2ply Bubinga + 1 outer ply Claro Walnut) w/Maple Sound Focus Rings
Size: 6.5"x14"
Lug: MTL160
Hoop: Sound Arc Hoop (10 Hole)
Strainer/Butt: MLS50A / MLS50B
Snare Wire: MS20RL14C
Color: Gloss Claro Walnut (GCW)

STAR RESERVE HAMMERED COPPER



TCS1465H

MADE IN JAPAN

Shell: 1.5mm Hammered Copper
Size: 6.5"x14"
Lug: MSL90S
Hoop: Customized Brass Mighty Hoop (8 Hole)
Strainer/Butt: MLS50A / MLS50B
Snare Wire: MS20RL14C

STAR RESERVE STAVE JATOBA



Color: Oiled Natural Jatoba -OJT

TVJ147S

NEW

MADE IN JAPAN

Shell: 10mm, 16pcs Stave Jatoba
Size: 7"x14"
Lug: MTL160
Hoop: Die-Cast Hoop (8 Hole)
Strainer/Butt: MLS50A / MLS50B
Snare Wire: MS20RL14C
Color: Oiled Natural Jatoba (OJT)

STARPHONIC MAPLE



Color: Satin Mappa Burl - STM

PMM146

MADE IN JAPAN

Shell: 6mm, 6ply Maple + 1 Mappa Burl outer ply
Size: 6"x14"
Lug: Freedom Lug
Hoop: Grooved Hoop
Strainer/Butt: MLS50A/MLS50B
Snare Wire: MS20RL14C
Color: Satin Mappa Burl (STM)

STARPHONIC BUBINGA



Color: Matte Natural Cordia -MNC

PBC146

MADE IN JAPAN

Shell: 7mm, 8ply Bubinga + 1 Cordia outer ply
Size: 6"x14"
Lug: Freedom Lug
Hoop: Grooved Hoop
Strainer/Butt: MLS50A/MLS50B
Snare Wire: MS20RL14C
Color: Matte Natural Cordia (MNC)

STARPHONIC BRASS



PBR146

MADE IN JAPAN

Shell: 1.2mm Brass
Size: 6"x14"
Lug: Freedom Lug
Hoop: Grooved Hoop
Strainer/Butt: MLS50A/MLS50B
Snare Wire: MS20RL14C

STARPHONIC BELL BRASS



PBB146

MADE IN JAPAN

Shell: 3mm Bell Brass
Size: 6"x14"
Lug: Freedom Lug
Hoop: Grooved Hoop
Strainer/Butt: MLS50A/MLS50B
Snare Wire: MS20RL14C

STARPHONIC COPPER



PCP147

NEW

MADE IN JAPAN

Shell: 1.2mm Copper
Size: 7"x14"
Lug: Freedom Lug
Hoop: Grooved Hoop
Strainer/Butt: MLS50A/MLS50B
Snare Wire: MS20RL14C

STARPHONIC ALUMINUM



PAL146

MADE IN JAPAN

Shell: 1.2mm Seamless Aluminum
Size: 6"x14"
Lug: Freedom Lug
Hoop: Grooved Hoop
Strainer/Butt: MLS50A/MLS50B
Snare Wire: MS20RL14C

STARPHONIC STAINLESS STEEL



PSS146

MADE IN JAPAN

Shell: 1mm Stainless Steel w/ R.S.E.
Size: 6"x14"
Lug: Freedom Lug
Hoop: Grooved Hoop
Strainer/Butt: MLS50A/MLS50B
Snare Wire: MS20RL14C

STARPHONIC STEEL



PST146

MADE IN JAPAN

Shell: 1mm Steel
Size: 6"x14"
Lug: Freedom Lug
Hoop: Grooved Hoop
Strainer/Butt: MLS50A/MLS50B
Snare Wire: MS20RL14C

STARPHONIC STEEL



PST137

MADE IN JAPAN

Shell: 1mm Steel
Size: 7"x13"
Lug: Freedom Lug
Hoop: Grooved Hoop
Strainer/Butt: MLS50A/MLS50B
Snare Wire: MS20RL13C

STARCLASSIC MAPLE EXOTIC FINISH



Color: Violet Fade Movingui -VLM

MES1465

Please refer to the Starclassic Maple Exotic Finishes drum kit page to see available sizes, finishes, and HW color option.

Lug: MSL-SCT
Hoop: Die-Cast Hoop
Strainer/Butt: MLS50A/MLS50B
Snare Wire: 14"=MS20RL14C,
13"=MS20RL13C

STARCLASSIC MAPLE LACQUER FINISH



Color: Antique Maple -ATM

MAS1455

Please refer to the Starclassic Maple Lacquer Finishes drum kit page to see available sizes, finishes, and HW color option. Antique Maple (ATM) finish is also available.

Lug: MSL-SCT
Hoop: Die-Cast Hoop
Strainer/Butt: MLS50A/MLS50B
Snare Wire: 14"=MS20RL14C,
13"=MS20RL13C

STARCLASSIC MAPLE DURACOVER WRAP FINISH



Color: Red and White Oyster -RWO

MRS1465 NEW

Please refer to the Starclassic Maple Duracover Wrap Finishes drum kit page to see available sizes, finishes, and HW color option.

Lug: MSL-SCT
Hoop: Die-Cast Hoop
Strainer/Butt: MLS50A/MLS50B
Snare Wire: 14"=MS20RL14C,
13"=MS20RL13C

STARCLASSIC WALNUT/BIRCH LACQUER FINISH



Color: Lacquer Phantasm Oyster -LPO

WBSS65 NEW

Please refer to the Starclassic Walnut/Birch Lacquer Finishes drum kit page to see available sizes and finishes.

Lug: MSL-SCT
Hoop: Die-Cast Hoop
Strainer/Butt: MCS70A/MCS70B
Snare Wire: 14"=MS20R14S, 13"=MS20R13S

STARCLASSIC WALNUT/BIRCH DURACOVER WRAP FINISH



Color: Jade Silk -JDL

WBRS65 NEW

Please refer to the Starclassic Walnut/Birch Duracover Wrap Finishes drum kit page to see available sizes and finishes.

Lug: MSL-SCT
Hoop: Die-Cast Hoop
Strainer/Butt: MCS70A/MCS70B
Snare Wire: 14"=MS20R14S, 13"=MS20R13S

S.L.P. G-MAPLE



Color: Kona Mappa Burl -KMB

LGM146 NEW

Shell: 11mm, 12ply Maple + 1 outer ply Mappa Burl
Size: 6"x14"
Lug: MSL-SCTBN
Hoop: Steel Mighty Hoop (10 Hole)
Strainer/Butt: MLS50A/MLS50BBN
Snare Wire: MS20RL14C
Color: Kona Mappa Burl (KMB)

S.L.P. G-MAPLE



Color: Satin Tamo Ash -STA

LGM137

Shell: 10mm, 11ply Maple + 1 outer ply Tamo Ash
Size: 7"x13"
Lug: MTL60
Hoop: Die-Cast Hoop (8 hole)
Strainer/Butt: MLS50A/MLS50B
Snare Wire: MS20SN13C
Color: Satin Tamo Ash (STA)

S.L.P. G-WALNUT



Color: Matte Black Walnut -MBW

LGW1465

Shell: 9mm, 10ply Walnut
Size: 6.5"x14"
Lug: MTL60
Hoop: Sound Arc Hoop (10 hole)
Strainer/Butt: MLS50A/MLS50B
Snare Wire: MS20R14S
Color: Matte Black Walnut (MBW)

S.L.P. DUO BIRCH



Color: Transparent Mocha -TPM

LBH1410L

Shell: 7mm, 7ply Birch
Size: 10"x14"
Lug: MSL-SCT
Hoop: Sound Arc Hoop (8 hole)
Strainer/Butt: MCS70A/MCS70B
Snare Wire: MS20R14S
Color: Transparent Mocha (TPM)
*MTB25E Brackets are equipped.
*MFLSL3P Legs are Included.

S.L.P. DYNAMIC KAPUR



Color: Black Kapur Burst -KPB

LKP1465

Shell: 5mm, 6ply Kapur
Size: 6.5"x14"
Lug: MTL60
Hoop: Sound Arc Hoop (8 hole)
Strainer/Butt: MLS50A/MLS50B
Snare Wire: MS20SN14S
Color: Black Kapur Burst (KPB)

S.L.P. FAT SPRUCE



Color: Wild Satin Spruce -WSS

LSP146

Shell: 7mm, 8ply Spruce
Size: 6"x14"
Lug: MTL60
Hoop: Die-Cast Hoop (8 hole)
Strainer/Butt: MLS50A/MLS50B
Snare Wire: MS20RL14C
Color: Wild Satin Spruce (WSS)

S.L.P. CLASSIC MAPLE



Color: Super Maple -SMP

LMP1455

Shell: 7mm, 8ply Maple
Size: 5.5"x14"
Lug: MTL50
Hoop: Sound Arc Hoop (10 hole)
Strainer/Butt: MLS50A/MLS50B
Snare Wire: MS20RL14C
Color: Super Maple (SMP)

S.L.P. STUDIO MAPLE



Color: Sienna -SEN

LMP1465F

Shell: 5mm, 6ply Maple w/ Sound Focus Rings
Size: 6.5"x14"
Lug: MSL-SCT
Hoop: 100% Maple Wood Hoop (8 hole)
Strainer/Butt: MLS50A/MLS50B
Snare Wire: MS20SN14S
Color: Sienna (SEN)

S.L.P. VINTAGE HAMMERED STEEL



LST1455H

Shell: 1.2mm Hammered Steel
Size: 5.5"x14"
Lug: MTL50
Hoop: Sound Arc Hoop (10 hole)
Strainer/Butt: MCS70A/MCS70B
Snare Wire: MS20RL14C

S.L.P. BLACK BRASS



LBR1465

Shell: 1.5mm Brass
Size: 6.5"x14"
Lug: MSL-SCTBN
Hoop: Steel Mighty Hoop (10 hole)
Strainer/Butt: MCS70ABN/MCS70BBN
Snare Wire: MS42R14S

S.L.P. BIG BLACK STEEL



LST148

Shell: 1mm Steel Shell in Matte Black Finish
Size: 8"x14"
Lug: MSL35BN
Hoop: Steel Mighty Hoop (10 hole)
Strainer/Butt: MCS70ABN/MCS70BBN
Snare Wire: MS20SN14S

S.L.P. CLASSIC DRY ALUMINUM



LAL1455

Shell: 1.2mm Seamless Aluminum
Size: 5.5"x14"
Lug: MCHL5S
Hoop: Steel Mighty Hoop (8 hole)
Strainer/Butt: MCS70A/MCS70B
Snare Wire: MS20RL14C

SOUNDWORKS MAPLE



Color: Matte Vintage Maple -MVM

DMP1255

Shell: 5mm, 6ply Maple
Size: 5.5"x12"
Lug: MSL60S
Hoop: Sound Arc Hoop (6 hole, 1.6mm)
Strainer/Butt: MCS70A/MCS70B
Snare Wire: MS20R12S
Color: Matte Vintage Maple (MVM)

SOUNDWORKS MAPLE



Color: Matte Vintage Maple -MVM

DMP1465

Shell: 5mm, 6ply Maple
Size: 6.5"x14"
Lug: MSL60S
Hoop: Sound Arc Hoop (10 hole)
Strainer/Butt: MCS70A/MCS70B
Snare Wire: MS20R14S
Color: Matte Vintage Maple (MVM)

SOUNDWORKS KAPUR



Color: Matte Brown Kapur -MRK

DKP137

Shell: 6mm, 7ply Maple
Size: 7"x13"
Lug: MSL60S
Hoop: Sound Arc Hoop (8 hole)
Strainer/Butt: MCS70A/MCS70B
Snare Wire: MS20R13S
Color: Matte Brown Kapur (MRK)

SOUNDWORKS KAPUR



Color: Matte Brown Kapur -MRK

DKP146

Shell: 6mm, 7ply Kapur
Size: 6"x14"
Lug: MSL60S
Hoop: Sound Arc Hoop (10 hole)
Strainer/Butt: MCS70A/MCS70B
Snare Wire: MS20R14S
Color: Matte Brown Kapur (MRK)

SOUNDWORKS STEEL



DST1055M

Shell: 1.2mm Steel
Size: 5.5"x10"
Lug: MSL60S
Hoop: Triple Flanged Hoop (6 hole)
Strainer/Butt: MCS70A/MCS70B
Snare Wire: MS16R10S
*Tom bracket is equipped.
*MC69 single tom attachment is included.

SOUNDWORKS STEEL



DST1465

Shell: 1.2mm Steel
Size: 6.5"x14"
Lug: MSL60S
Hoop: Steel Mighty Hoop (10 hole)
Strainer/Butt: MCS70A/MCS70B
Snare Wire: MS20R14S

METALWORKS



BST1055MBK

Shell: 1.2mm Steel
Size: 5.5"x10"
Lug: MSL60S
Hoop: Triple Flanged Hoop (6 hole)
Strainer/Butt: MUS65A/MUS60B
Snare Wire: MS16R10S
*Tom bracket is equipped.

NEW

METALWORKS



BST1455BK NEW

Shell: 1.2mm Steel
Size: 5.5"x14"
Lug: MSL60S
Hoop: Triple Flanged Hoop (8 hole)
Strainer/Butt: MUS65A/MUS60B
Snare Wire: MS20R14S

METALWORKS



BST1465BK NEW

Shell: 1.2mm Steel
Size: 6.5"x14"
Lug: MSL60S
Hoop: Triple Flanged Hoop (8 hole)
Strainer/Butt: MUS65A/MUS60B
Snare Wire: MS20R14S

MINI-TYMP SNARE DRUMS



STS065M

Shell: 1mm Steel
Size: 5"x6"
Lug: MSL60T
Hoop: Triple Flanged Hoop (4 hole)
Snare Wire: Half-set Snare Wires
*Tom bracket is equipped.
*MC69 single tom attachment is included.

MINI-TYMP SNARE DRUMS



STS085M

Shell: 1mm Steel
Size: 5"x8"
Lug: MSL60T
Hoop: Triple Flanged Hoop (4 hole)
Snare Wire: Half-set Snare Wires
*Tom bracket is equipped
*MC69 single tom attachment is included.

MINI-TYMP SNARE DRUMS



STS105M

Shell: 1mm Steel
Size: 5"x10"
Lug: MSL60T
Hoop: Triple Flanged Hoop (6 hole)
Snare Wire: Half-set Snare Wires
*Tom bracket is equipped
*MC69 single tom attachment is included.

SIGNATURE PALETTE -KENNY ARONOFF



KA145N

Trackmaster
Shell: 1mm Brass
Size: 5"x14"
Lug: MSL35
Hoop: Die-Cast Hoop (10 hole)
Strainer/Butt: MUS80A/MUS80B
Snare Wire: MS20SN14S

MADE IN JAPAN

SIGNATURE PALETTE -KENNY ARONOFF



KA1465

Trackmaster
Shell: 1mm Brass
Size: 6.5"x14"
Lug: MSL35 (Nickel)
Hoop: Brass Mighty Hoop (10 hole)
Strainer/Butt: MUS80A/MUS80B (Nickel)
Snare Wire: MS20SN14S

MADE IN JAPAN

SIGNATURE PALETTE -CHARLIE BENANTE



CB1465

Shell: 1.2mm Stainless Steel
Size: 6.5"x14"
Lug: MSL35BN
Hoop: Die-Cast Hoop (10 hole)
Strainer/Butt: MUS80ABN/MUS80BBN
Snare Wire: MS20SN14S

MADE IN JAPAN

SIGNATURE PALETTE -STEWART COPELAND



SC145

Shell: 1.5mm Brass
Size: 5"x14"
Lug: MSL35
Hoop: Die-Cast Hoop (10 hole, Batter side)/Steel Mighty Hoop (10 hole, Snare side)
Strainer/Butt: MUS80A/MUS80B
Snare Wire: MS20SN14S

MADE IN JAPAN

SIGNATURE PALETTE -PETER ERSKINE



PE106M

Shell: 10mm, 12pcs Stave Ash
Size: 6"x10"
Lug: MSL90S
Hoop: Die-Cast Hoop (6 Hole)
Strainer/Butt: MSL50A / MSL50B
Snare Wire: MS20SN10S
Super Resonant Mounting System Equipped

MADE IN JAPAN

SIGNATURE PALETTE -SIMON PHILLIPS



SP125H

The Pageant
Shell: 6mm, 7ply Figured Maple w/ 6mm Sound Focus Rings
Size: 5"x12"
Lug: MSL35H
Hoop: Die-Cast Hoop (6 hole, Brushed Nickel)
Strainer/Butt: MUS80AH/MUS80BH
Snare Wire: MS20S-12S

MADE IN JAPAN

SIGNATURE PALETTE -SIMON PHILLIPS



SP1455H

The Gladiator
Shell: 1mm Bronze
Size: 5.5"x14"
Lug: MSL35H
Hoop: Brass Mighty Hoop (10 hole, Brushed Nickel)
Strainer/Butt: MUS80AH/MUS80BH
Snare Wire: MS20S-S

MADE IN JAPAN

SIGNATURE PALETTE -SIMON PHILLIPS



SP1465H

MADE IN JAPAN

The Monarch
Shell: 6mm, 3ply Figured Maple/3ply
Bubinga/2ply Maple w/ 6mm Sound Focus Rings
Size: 6.5"x14"
Lug: MSL-SCTH
Hoop: Customized Brass Mighty Hoop (8 hole,
Brushed Nickel)
Strainer/Butt: MUS80AH/MUS80BH
Snare Wire: MS20S-S

SIGNATURE PALETTE -MIKE PORTNOY



MP125ST

MADE IN JAPAN

Shell: 1mm Steel (Hammered Matte Black)
Size: 5"x12"
Lug: MSL-SCT
Hoop: Die-Cast Hoop (6 hole)
Strainer/Butt: MCS100A/MCS70B
Snare Wire: MS20SN12S

SIGNATURE PALETTE -MIKE PORTNOY



MP1455ST

MADE IN JAPAN

Shell: 1mm Steel (Hammered Matte Black)
Size: 5.5"x14"
Lug: MSL-SCT
Hoop: Die-Cast Hoop (8 hole)
Strainer/Butt: MCS100A/MCS70B
Snare Wire: MS20SN14S

SIGNATURE PALETTE -MIKE PORTNOY



MP1455BU

MADE IN JAPAN

Shell: 8mm, 9ply Bubinga
Size: 5.5"x14"
Lug: MSL-SCT
Hoop: Die-Cast Hoop (8 hole)
Strainer/Butt: MCS100A/MCS70B
Snare Wire: MS20SN14S

SIGNATURE PALETTE -JOHN TEMPESTA



JT147

MADE IN JAPAN

Shell: 2mm Brass
Size: 7"x14"
Lug: MSL-SCTBN
Hoop: Die-Cast Hoop (10 hole)
Strainer/Butt: MUS80ABN/MUS80BBN
Snare Wire: MS42R14S

SIGNATURE PALETTE -LARS ULRICH



LU1465N

MADE IN JAPAN

Shell: 3mm Diamond Plate Steel
Size: 6.5"x14"
Lug: MSL35
Hoop: Die-Cast Hoop (10 hole)
Strainer/Butt: MUS80A/MUS80B
Snare Wire: MS20SN14S



DRUM PEDALS

Our Iron Cobra pedals have long been praised for being smooth, reliable, and independently adjustable. Iron Cobra pedals are offered in the high end 900 series as well as the standard 600 and 200 models. Speed Cobra 910 and 310 drum pedals feature a longer footboard for a lighter, quicker feel. Our drum pedal range is designed to fit the needs of every drummer.

SPEED COBRA 910 SINGLE PEDAL



HP910LN

- Long Footboard
- Recessed Setting
- Rolling Glide LiteSprocket Cam
- Accu-Strike Cobra Beater
- Swivel Spring Tight
- Super Stabilizer Design
- Para-Clamp II Pro
- Cobra Coil
- Hinge Guard Block
- Hardshell Carrying Case

SPEED COBRA 910 TWIN PEDAL



HP910LWN

- Long Footboard
- Recessed Setting
- Rolling Glide LiteSprocket Cam
- Accu-Strike Cobra Beater
- Swivel Spring Tight
- Super Stabilizer Design
- Para-Clamp II Pro
- Cobra Coil
- Hinge Guard Block
- Hardshell Carrying Case

SPEED COBRA 910 TWIN PEDAL



HP910LWLN

- Left-Footed
- Long Footboard
- Recessed Setting
- Rolling Glide LiteSprocket Cam
- Accu-Strike Cobra Beater
- Swivel Spring Tight
- Super Stabilizer Design
- Para-Clamp II Pro
- Cobra Coil
- Hinge Guard Block
- Hardshell Carrying Case

IRON COBRA 900 SINGLE PEDAL -POWER GLIDE-



HP900PN

- Power Glide LiteSprocket Cam
- Power-Strike Cobra Beater
- Swivel Spring Tight
- Super Stabilizer Design
- Para-Clamp II Pro
- Cobra Coil
- Hinge Guard Block
- Hardshell Carrying Case

IRON COBRA 900 TWIN PEDAL -POWER GLIDE-



HP900PWN

- Power Glide LiteSprocket Cam
- Power-Strike Cobra Beater
- Swivel Spring Tight
- Super Stabilizer Design
- Para-Clamp II Pro
- Cobra Coil
- Hinge Guard Block
- Hardshell Carrying Case

IRON COBRA 900 TWIN PEDAL -POWER GLIDE-



HP900PWLN

- Left-Footed
- Power Glide LiteSprocket Cam
- Power-Strike Cobra Beater
- Swivel Spring Tight
- Super Stabilizer Design
- Para-Clamp II Pro
- Cobra Coil
- Hinge Guard Block
- Hardshell Carrying Case

IRON COBRA 900 SINGLE PEDAL -ROLLING GLIDE-



HP900RN

- Rolling Glide LiteSprocket Cam
- Power-Strike Cobra Beater
- Swivel Spring Tight
- Super Stabilizer Design
- Para-Clamp II Pro
- Cobra Coil
- Hinge Guard Block
- Hardshell Carrying Case

IRON COBRA 900 TWIN PEDAL -ROLLING GLIDE-



HP900RWN

- Rolling Glide LiteSprocket Cam
- Power-Strike Cobra Beater
- Swivel Spring Tight
- Super Stabilizer Design
- Para-Clamp II Pro
- Cobra Coil
- Hinge Guard Block
- Hardshell Carrying Case

IRON COBRA 600 SINGLE PEDAL -DUO GLIDE-



HP600D

- Duo Glide
- Double Chain Drive
- Speedo-Ring
- Para-Clamp
- Spring Tension Adjustment
- Beater Angle Adjustment
- Dual Sided Beater

IRON COBRA 600 TWIN PEDAL -DUO GLIDE-



HP600DTW

- Duo Glide
- Double Chain Drive
- Speedo-Ring
- Para-Clamp
- Spring Tension Adjustment
- Beater Angle Adjustment
- Dual Sided Beater

SPEED COBRA 310 SINGLE PEDAL



HP310L

- Long Footboard
- Recessed Setting
- Rolling Glide LiteSprocket
- Double Chain Drive
- Spring Tension Adjustment
- Beater Angle Adjustment
- Dual Sided Beater

SPEED COBRA 310 TWIN PEDAL



HP310LW

- Long Footboard
- Recessed Setting
- Rolling Glide LiteSprocket
- Double Chain Drive
- Spring Tension Adjustment
- Beater Angle Adjustment
- Dual Sided Beater

IRON COBRA 200 SINGLE PEDAL



HP200P

- Power Glide
- Spring Tension Adjustment
- Beater Angle Adjustment
- Dual Sided Beater

IRON COBRA 200 TWIN PEDAL



HP200PTW

- Power Glide
- Spring Tension Adjustment
- Beater Angle Adjustment
- Dual Sided Beater

STANDARD SINGLE PEDAL



HP30

- Power Glide
- Spring Tension Adjustment
- Beater Angle Adjustment
- Dual Sided Beater

THE CLASSIC PEDAL



HP50

- Center Strike Height Adjust
- Easy Access Spring Adjustment
- The Classic Beater
- Smooth Surface Footboard
- Individual Adjustment of Beater & Footboard Angle
- Easy-Tight Hoop Clamp
- Compact Folding Design

RHYTHM MATE SINGLE PEDAL



HP10

- Power Glide
- Spring Tension Adjustment
- Beater Angle Adjustment
- Traditional Felt Beater

COBRA CLUTCH



HH905XP

A hi-hat control solution for double bass players! Instead of the loose, inexact, drop-clutch approach, the Cobra Clutch delivers a precise, fine-tuned degree of cymbal closure pressure, that's easily engaged and disengaged with a simple tap of the foot.

TWIN PEDAL ATTACHMENT



TPA90

Specially designed attachment to connect Speed Cobra 910 and Iron Cobra 900 series pedals with Speed Cobra 910 and Iron Cobra 900 series Hi-hat stands.

HI-HAT STANDS

In addition to bass drum pedals, we offer various hi-hat stands including our high end Iron Cobra & Speed Cobra models.

SPEED COBRA 910 HI-HAT STAND - LEVER GLIDE



HH915D

- Spring Seat
- Quick-Set Hi-Hat Clutch
- 6-way Tension Adjustment
- Oiles® Bearing Hinge
- Spare-The-Rods Tension Rod Protector
- Non-Loosening Tension Rod
- Glide-Tite Grip Joint
- Bigger Rubber Feet w/Duo-Spike
- Weight: 5.2kg (11.7lbs)
- Height Adjustment Range:
745mm-960mm (29 3/8" - 37 3/4") (Standard Rod) /
745mm-810mm (29 3/8" - 31 7/8") (Short Rod)

IRON COBRA 900 HI-HAT STAND -LEVER GLIDE



HH905D

- Spring Seat
- Quick-Set Hi-Hat Clutch
- 6-way Tension Adjustment
- Oiles® Bearing Hinge
- Spare-The-Rods Tension Rod Protector
- Non-Loosening Tension Rod
- Glide-Tite Grip Joint
- Bigger Rubber Feet w/Duo-Spike
- Weight: 5.2kg (11.7lbs)
- Height Adjustment Range:
745mm-960mm (29 3/8" - 37 3/4") (Standard Rod) /
745mm-810mm (29 3/8" - 31 7/8") (Short Rod)

IRON COBRA 900 HI-HAT STAND -VELO GLIDE



HH805D

- Spring Seat
- Quick-Set Hi-Hat Clutch
- 6-way Tension Adjustment
- Oiles® Bearing Hinge
- Spare-The-Rods Tension Rod Protector
- Non-Loosening Tension Rod
- Glide-Tite Grip Joint
- Bigger Rubber Feet w/Duo-Spike
- Weight: 5.2kg (11.7lbs)
- Height Adjustment Range:
745mm-960mm (29 3/8" - 37 3/4") (Standard Rod) /
745mm-810mm (29 3/8" - 31 7/8") (Short Rod)

IRON COBRA 900 REMOTE HI-HAT STAND



HH905RH

- JAGWIRE™ Triple-Layered Ultra-Smooth Cable
- Quick-Set Hi-Hat Clutch
- Lever Glide
- 6-way Tension Adjustment
- Non-Loosening Tension Rod
- MC66 Universal Clamp
- Ratchet Arm (Ø12mm, Arm Length: 200mm)
- Dual Leg
- Cable Holders (x 6)
- Carrying Bag
- Weight: 8.1kg (17lbs)

IRON COBRA 600 HI-HAT STAND



HH605

- Spring Seat
- Swing Lock Clutch
- 6-way Tension Adjustment
- Swivel Foot
- Direct Pull Action
- Spare-The-Rods Tension Rod Protector
- Non-Loosening Tension Rod
- Footboard Angle Adjustment
- Weight: 4.3kg (9.7lbs)
- Height Adjustment Range: 710mm-930mm (28" - 36 5/8")

SPEED COBRA 310 HI-HAT STAND



HH315D

- Dual Leg
- 28.6mm Diameter Base Section Tubing
- Security Clutch
- 6-way Tension Adjustment
- Swivel Foot
- Direct Pull Action
- Spare-The-Rods Tension Rod Protector
- Non-Loosening Tension Rod
- Weight: 3.9kg (8.9lbs)
- Height Adjustment Range: 710mm-930mm (28" - 36 5/8")

IRON COBRA 200 HI-HAT STAND



HH205

- 5-way Tension Adjustment
- Swivel Foot
- Direct Pull Action
- Non-Loosening Tension Rod
- Toe Guard
- Security Clutch
- Weight: 3.8kg (8.6lbs)
- Height Adjustment Range: 670mm-930mm (26 3/8" - 36 5/8")

IRON COBRA 200 HI-HAT STAND



HH205S

NEW

- Single Braced Legs
- 5-way Tension Adjustment
- Swivel Foot
- Direct Pull Action
- Non-Loosening Tension Rod
- Toe Guard
- Security Clutch
- Weight: 3.1kg (6.1lbs)
- Height Adjustment Range: 670mm-930mm (26 3/8" - 36 5/8")

THE CLASSIC HI-HAT STAND



HH55F

- Single Braced Flat Base Tripod Legs
- Smooth Surface Footboard
- Individual Adjustment of Spring Tension & Footboard Angle
- Knurling on Base Pipe
- Die-Cast Pipe Joint / Memory Lock
- Easy Store Radius Rod
- Weight: 2.3kg (5.1lbs)
- Height Adjustment Range: 650mm-950mm (26 3/8" - 36 5/8")
- Storage size: 500mm (19 11/16") (upper section) / 600mm (23 5/8") (lower section)

DRUM THRONES

Being comfortable on your drum set is one of the most important aspects of drumming, making the drum throne a vital yet often overlooked piece of equipment. Our ergonomic 1st Chair Drum Thrones have many original TAMA features to guarantee comfort, stability, and quick, easy setup.

1ST CHAIR ROUND RIDER XL DRUM THRONE -CLOTH TOP



HT850BC

- Round Rider XL "Cloth Top" Seat
- 15" Diameter, 130mm (5 1/8") Thick Round Seat
- HYDRAULIX
- Seat Lock
- Oversized Rubber Feet
- Foot Life
- Weight: 6.0kg (13.3lbs)
- Height Adjustment Range: 515mm - 695mm (21 1/4" - 27 3/8")

1ST CHAIR ROUND RIDER XL DRUM THRONE



HT830R

- Round Rider XL Seat
- 15" Diameter, 130mm (5 1/8") Thick Round Seat
- 1st Chair Height Adjustment
- Seat Lock
- Glide-Tite Grip Joint
- Rocklok
- Oversized Rubber Feet
- Foot Life
- Weight: 6.0kg (13.3lbs)
- Height Adjustment Range: 515mm - 670mm (21 1/4" - 26 3/8")

1ST CHAIR ROUND RIDER XL DRUM THRONE



HT830B

- Round Rider XL Seat
- 15" Diameter, 130mm (5 1/8") Thick Round Seat
- 1st Chair Height Adjustment
- Seat Lock
- Glide-Tite Grip Joint
- Rocklok
- Oversized Rubber Feet
- Foot Life
- Weight: 6.0kg (13.3lbs)
- Height Adjustment Range: 515mm - 670mm (21 1/4" - 26 3/8")

1ST CHAIR ERGO-RIDER DRUM THRONE -CLOTH TOP



HT750BC

- Ergo-Rider "Cloth Top" Seat
- HYDRAULIX
- Seat Lock
- Oversized Rubber Feet
- Foot Life
- Weight: 6.1kg (13.7lbs)
- Height Adjustment Range: 505mm - 685mm (19 7/8" - 27")

1ST CHAIR ERGO-RIDER DRUM THRONE



HT730B

Ergo-Rider Seat
 -1st Chair Height Adjustment
 -Seat Lock
 -Glide-Tite Grip Joint
 -Rocklok
 -Oversized Rubber Feet
 -Foot Life
 -Weight: 6.1kg (13.7lbs)
 -Height Adjustment Range: 505mm - 660mm (19 7/8" - 26")

1ST CHAIR ERGO-RIDER DRUM THRONE -QUARTET



HT741B

Ergo-Rider Seat
 -1st Chair Height Adjustment
 -Seat Lock
 -Backrest
 -Glide-Tite Grip Joint
 -Rocklok
 -Oversized Rubber Feet
 -Foot Life
 -Weight: 9.4kg (20.1lbs)
 -Height Adjustment Range: 515mm - 665mm (20 1/4" - 26 3/16")

1ST CHAIR GLIDE RIDER DRUM THRONE -CLOTH TOP



HT550BCN

Glide Rider "Cloth Top" Seat
 -HYDRAULIX
 -Seat Lock
 -Glide-Tite Grip Joint
 -Rocklok
 -Oversized Rubber Feet
 -Foot Life
 -Weight: 5.9kg (13lbs)
 -Height Adjustment Range: 470mm - 650mm (18 1/2" - 24 5/8")

1ST CHAIR GLIDE RIDER DRUM THRONE -CLOTH TOP



HT530BCN

Glide Rider "Cloth Top" Seat
 -1st Chair Height Adjustment
 -Seat Lock
 -Glide-Tite Grip Joint
 -Rocklok
 -Oversized Rubber Feet
 -Foot Life
 -Weight: 5.9kg (13lbs)
 -Height Adjustment Range: 470mm - 650mm (18 1/2" - 24 5/8")

1ST CHAIR WIDE RIDER DRUM THRONE -CLOTH TOP



HT530BC

Wide Rider "Cloth Top" Seat
 -1st Chair Height Adjustment
 -Seat Lock
 -Glide-Tite Grip Joint
 -Rocklok
 -Oversized Rubber Feet
 -Foot Life
 -Weight: 6.0kg (13.3lbs)
 -Height Adjustment Range: 485mm - 640mm (19" - 25 3/16")

1ST CHAIR WIDE RIDER DRUM THRONE



HT530B

Wide Rider Seat
 -1st Chair Height Adjustment
 -Seat Lock
 -Glide-Tite Grip Joint
 -Rocklok
 -Oversized Rubber Feet
 -Foot Life
 -Weight: 6.0kg (13.3lbs)
 -Height Adjustment Range: 485mm - 640mm (19" - 25 3/16")

1ST CHAIR ROUND RIDER DRUM THRONE -CLOTH TOP



HT430BC

Round Rider "Cloth Top" Seat
 -14" Diameter, 120mm (4 3/4") Thick Round Seat
 -1st Chair Height Adjustment
 -Seat Link
 -Rocklok
 -Foot Life
 -Weight: 5.3kg (11.1lbs)
 -Height Adjustment Range: 485mm - 655mm (19" - 25 3/4")

1ST CHAIR ROUND RIDER DRUM THRONE



HT430B

Round Rider Seat
 -14" Diameter, 120mm (4 3/4") Thick Round Seat
 -1st Chair Height Adjustment
 -Seat Link
 -Rocklok
 -Foot Life
 -Weight: 5.3kg (11.1lbs)
 -Height Adjustment Range: 485mm - 655mm (19" - 25 3/4")

ROADPRO DRUM THRONE



HT75WNBR

NEW

Saddle Type Seat
 -Threaded Rod Height Adjustment
 -Double Braced Legs
 -Seat Link
 -Weight: 4.8kg (10.9lbs)
 -Height Adjustment Range: 480-650mm (18 7/8" - 25 5/8")

ROADPRO DRUM THRONE



HT75WN

NEW

Saddle Type Seat
 -Threaded Rod Height Adjustment
 -Double Braced Legs
 -Seat Link
 -Weight: 4.8kg (10.9lbs)
 -Height Adjustment Range: 480-650mm (18 7/8" - 25 5/8")

ROADPRO DRUM THRONE



HT65WNBR

- 13" Diameter, 90mm (3 1/2") Thick Round Seat
- Threaded Rod Height Adjustment
- Seat Link
- Double Braced Legs
- Weight: 4.6kg (10.2lbs)
- Height Adjustment Range: 480-650mm (18 7/8"-25 5/8")

ROADPRO DRUM THRONE



HT65WN

- 13" Diameter, 90mm (3 1/2") Thick Round Seat
- Threaded Rod Height Adjustment
- Seat Link
- Double Braced Legs
- Weight: 4.6kg (10.2lbs)
- Height Adjustment Range: 480-650mm (18 7/8"-25 5/8")

STANDARD DRUM THRONE



HT130

- 13" Diameter, 90mm (3 1/2") Thick Round Seat
- Double Braced Legs
- Weight: 3.4kg (7.7lbs)
- Height Adjustment Range: 445mm - 620mm (17 1/2" - 24 7/16")

SNARE STANDS

Our STAR snare stand has several unique features which provide the ultimate solution for a flexible and stable snare drum setup. Our Roadpro stands now have greater stability, in addition to Quick-Set universal tilters.

STAR HARDWARE SNARE STAND



HS100W

- For 12" to 15" Diameter Snare Drums
- 28.6mm Diameter Base Section Tubing
- Omni-Ball Tilter
- Cradle-Hold Snare Basket
- Glide-Tite Grip Joint
- True-Sound Insulation Mute
- Oversized Rubber Feet with Retractable Spike
- Extra Heavy Double Braced Legs
- Weight: 3.9kg (8.9lbs)
- Height Adjustment Range: 400mm - 600mm (15 3/4" - 23 5/8")

ROADPRO SNARE STAND



HS800W

- For 12" to 15" Diameter Snare Drums
- 28.6mm Diameter Base Section Tubing
- Omni-Ball Tilter
- Swiveling Basket
- Glide-Tite Grip Joint
- Double Braced Legs
- Weight: 3.4kg (7.7lbs)
- Height Adjustment Range: 495mm - 665mm (19 1/2" - 26 3/8")

ROADPRO SNARE STAND



HS80W

- For 12" to 15" Diameter Snare Drums
- 28.6mm Diameter Base Section Tubing
- Quick-Set Tilter
- Swiveling Basket
- Glide-Tite Grip Joint
- Double Braced Legs
- Weight: 3.2kg (7lbs)
- Height Adjustment Range: 495mm - 640mm (19 1/2" - 25 3/16")

ROADPRO SNARE STAND



HS80PW

- For 10" to 12" Diameter Snare Drums
- 28.6mm Diameter Base Section Tubing
- Quick-Set Tilter
- Swiveling Basket
- Glide-Tite Grip Joint
- Double Braced Legs
- Weight: 3.2kg (7lbs)
- Height Adjustment Range: 465mm - 610mm (18 5/16" - 24")

ROADPRO SNARE STAND



HS80LOW

For 12" to 15" Diameter Snare Drums
-28.6mm Diameter Base Section Tubing
-Low Position Setting Basket
-Quick-Set Tilter
-Glide-Tite Grip Joint
-Double Braced Legs
-Weight: 3.3kg (7.4lbs)
-Height Adjustment Range: 385mm - 530mm (15 3/16" - 20 7/8")

60 SERIES SNARE STAND



HS60W

For 12" to 15" Diameter Snare Drums
-25.4mm Diameter Base Section Tubing
-Quick-Set Tilter
-Swiveling Basket
-Double Braced Legs
-Weight: 2.6kg (5.1lbs)
-Height Adjustment Range: 470mm - 600mm (18 1/2" - 23 5/8")

STAGE MASTER SNARE STAND



HS40WN

NEW

For 12" to 15" Diameter Snare Drums
-25.4mm Diameter Base Section Tubing
-Universal Gearless Tilter
-Swiveling Basket
-Double Braced Legs
-Weight: 2.6kg (5.11lbs)
-Height Adjustment Range: 470mm - 630mm (18 1/2" - 24 13/16")

STAGE MASTER SNARE STAND



HS40SN

NEW

For 12" to 15" Diameter Snare Drums
-25.4mm Diameter Base Section Tubing
-Universal Gearless Tilter
-Swiveling Basket
-Single Braced Legs
-Weight: 2.5kg (5.8lbs)
-Height Adjustment Range: 470mm - 630mm (18 1/2" - 24 13/16")

STAGE MASTER SNARE STAND



HS40LOWN

NEW

For 12" to 15" Diameter Snare Drums
-25.4mm Diameter Base Section Tubing
-Low Position Setting Basket
-Universal Gearless Tilter
-Double Braced Legs
-Weight: 2.7kg (5.15lbs)
-Height Adjustment Range: 370mm - 530mm (14 9/16" - 20 7/8")

THE CLASSIC SNARE STAND



HS50S

For 12" to 15" Diameter Snare Drums
-19.1mm Diameter Base Section Tubing
-Single Braced Tripod Legs
-Classic Style Basket
-Double Braced Arms
-Gearless Tilter
-Die-Cast Pipe Joint / Memory Lock
-Weight: 1.7kg (3.11lbs)
-Height Adjustment Range: 390mm-580mm (15 3/8" - 22 7/8")
-Storage size: 600mm (23 5/8")

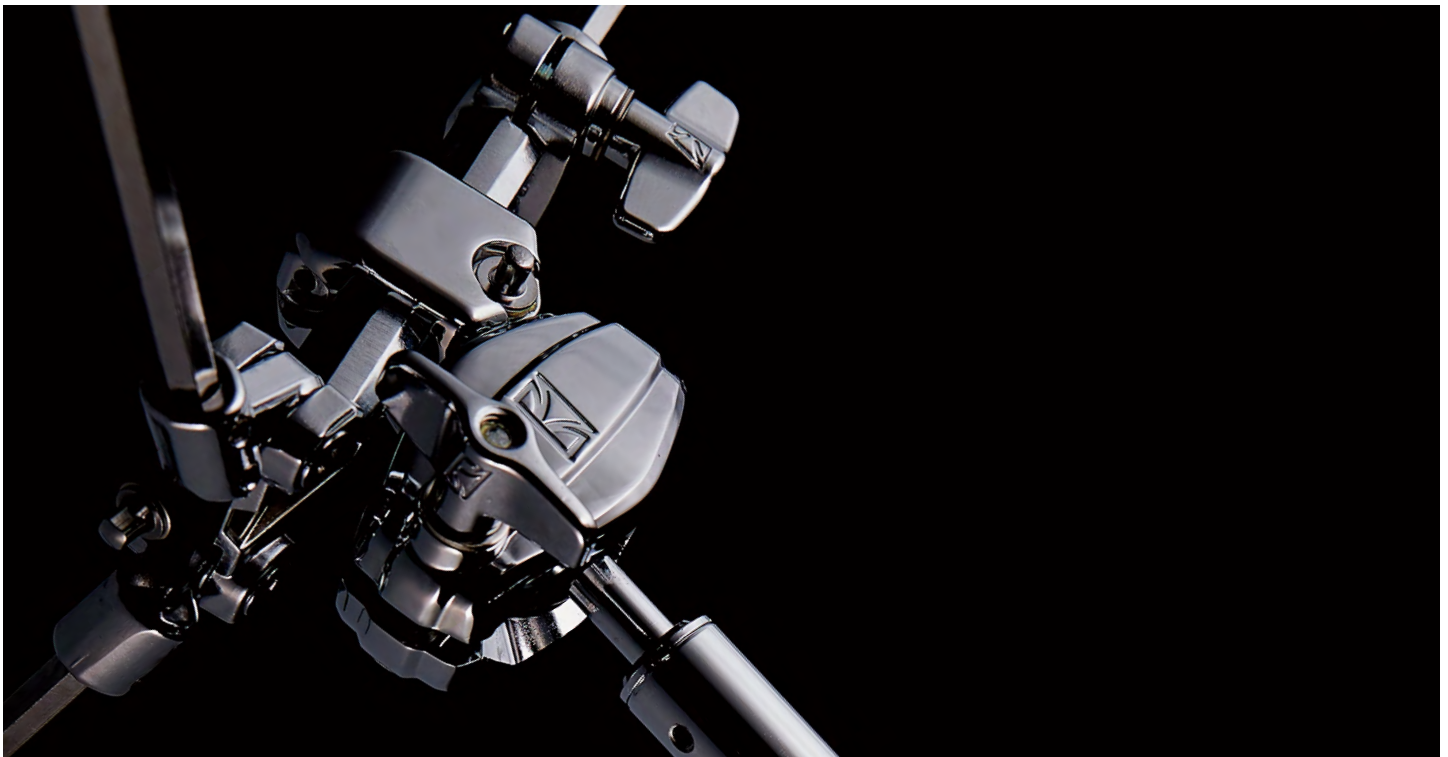

CYMBAL STANDS

The TAMA STAR Hardware cymbal stand is incredibly flexible with several groundbreaking adjustment features. The Roadpro cymbal stands benefit from greater stability, and include the same great Quick-Set Tilter and Quick-Set Cymbal Mates.

STAR HARDWARE CYMBAL STAND



HC103BW

- 28.6mm Diameter Base Section Tubing
- Orbital Quick-Tite Cymbal Tilter
- Orbital Quick-Tite Boom Tilter
- Glide-Tite Grip Joint
- True-Sound Insulation Mute
- Ring-True Cymbal Felt
- Quick-Set Cymbal Mate
- Oversized Rubber Feet
- Extra Heavy Double Braced Legs
- Boom Arm Length: 450mm (17 3/4")
- Weight: 6.1kg (13.7lbs)
- Height Adjustment Range: 890mm - 2,090mm (35" - 82 1/4")

ROADPRO CYMBAL STAND



HC84BW

- 28.6mm Diameter Base Section Tubing
- Quick-Set Tilter
- Quick-Set Cymbal Mate
- Boom/Straight Convertible Tilter
- Glide-Tite Grip Joint
- Double Braced Legs
- Detachable Counter Weight
- Boom Arm Length (incl. Counter Weight): 688mm (27 3/32")
- Weight (incl. Counter Weight): 6.2kg (13.10lbs)
- Height Adjustment Range: 820mm - 2,200mm (32 1/4" - 86 5/8")

ROADPRO CYMBAL STAND



HC83BW

- 28.6mm Diameter Base Section Tubing
- Quick-Set Tilter
- Quick-Set Cymbal Mate
- Boom/Straight Convertible Tilter
- Glide-Tite Grip Joint
- Double Braced Legs
- Boom Arm Length: 450mm (17 3/4")
- Weight: 5.0kg (11lbs)
- Height Adjustment Range: 820mm - 2,100mm (32 1/4" - 82 5/8")

ROADPRO CYMBAL STAND



HC82W

- 28.6mm Diameter Base Section Tubing
- Quick-Set Tilter
- Quick-Set Cymbal Mate
- Glide-Tite Grip Joint
- Double Braced Legs
- Weight: 4.2kg (9.4lbs)
- Height Adjustment Range: 740mm - 1,610mm (29 1/8" - 63 3/8")

ROADPRO LIGHT CYMBAL STAND



HC83BLS

- 25.4mm Diameter Base Section Tubing
- Quick-Set Tilter
- Quick-Set Cymbal Mate
- Boom/Straight Convertible Tilter
- Glide-Tite Grip Joint
- Single Braced Legs
- Boom Arm Length: 400mm (15 3/4")
- Weight: 3.8kg (8.6lbs)
- Height Adjustment Range: 790mm - 1,850mm (31 1/8" - 72 7/8")

ROADPRO LIGHT CYMBAL STAND



HC82LS

- 25.4mm Diameter Base Section Tubing
- Quick-Set Tilter
- Quick-Set Cymbal Mate
- Glide-Tite Grip Joint
- Single Braced Legs
- Weight: 3.1kg (6.13lbs)
- Height Adjustment Range: 710mm - 1,410mm (28" - 55 1/2")

60 SERIES CYMBAL STAND



HC63BW

- 25.4mm Diameter Base Section Tubing
- Quick-Set Tilter
- Boom/Straight Convertible Tilter
- Double Braced Legs
- Boom Arm Length: 400mm (15 3/4")
- Weight: 3.9kg (8.9lbs)
- Height Adjustment Range: 850mm - 2,010mm (33 1/2" - 79 1/8")

60 SERIES CYMBAL STAND



HC62W

- 25.4mm Diameter Base Section Tubing
- Quick-Set Tilter
- Double Braced Legs
- Weight: 3.2kg (3lbs)
- Height Adjustment Range: 780mm - 1,620mm (30 3/4" - 63 3/4")

STAGE MASTER CYMBAL STAND



HC43BWN

NEW

- 25.4mm Diameter Base Section Tubing
- Fine Gear Tilter
- Quick-Set Cymbal Mate
- Boom/Straight Convertible Tilter
- Double Braced Legs
- Boom Arm Length: 400mm (15 3/4")
- Weight: 3.4kg (7.7lbs)
- Height Adjustment Range: 760mm - 1,800mm (30" - 70 13/16")

STAGE MASTER CYMBAL STAND



HC43BSN

NEW

- 25.4mm Diameter Base Section Tubing
- Fine Gear Tilter
- Quick-Set Cymbal Mate
- Boom/Straight Convertible Tilter
- Single Braced Legs
- Boom Arm Length: 400mm (15 3/4")
- Weight: 3.2kg (7lbs)
- Height Adjustment Range: 760mm - 1,800mm (30" - 70 13/16")

STAGE MASTER CYMBAL STAND



HC42WN

NEW

- 25.4mm Diameter Base Section Tubing
- Fine Gear Tilter
- Quick-Set Cymbal Mate
- Double Braced Legs
- Weight: 2.9kg (6.6lbs)
- Height Adjustment Range: 690mm - 1,420mm (27 1/8" - 55 15/16")

STAGE MASTER CYMBAL STAND



HC42SN

NEW

- 25.4mm Diameter Base Section Tubing
- Fine Gear Tilter
- Quick-Set Cymbal Mate
- Single Braced Legs
- Weight: 2.7kg (5.15lbs)
- Height Adjustment Range: 690mm - 1,420mm (27 1/8" - 55 15/16")

THE CLASSIC CYMBAL STAND



HC52F

- 19.1mm Diameter Base Section Tubing
- Flat Base Leg Design
- 9mm Diameter Solid Upper Portion
- Fine Gear Tilter
- Compact Folding Design (580mm 22 27/32")
- Weight 1.48kg (3.2lbs)
- Height Adjustment Range: 590mm - 1,300mm (23 1/4" - 51 3/16")



TOM STANDS & TOM HOLDERS

TAMA's tom stands and tom holders feature our original Omni-Ball system which allows each tom to be held securely in place. You can position the drum at virtually any angle simply by loosening one T-nut.

STAR HARDWARE COMBINATION STAND



HTC107W

- 28.6mm Diameter Base Section Tubing
- Swivel-Wing Tom Holder
- Orbital Quick-Tite Cymbal Tilter
- Orbital Quick-Tite Boom Tilter
- Glide-Tite Grip Joint
- True-Sound Insulation Mute
- Ring-True Cymbal Felt
- Extra Heavy Double Braced Legs
- Boom Arm Length: 300mm (11 3/4")
- Weight: 7.2kg (15.13lbs)

STAR HARDWARE DOUBLE TOM STAND



HTW109W

- 28.6mm Diameter Base Section Tubing
- Swivel-Wing Tom Holder
- Stilt System
- Glide-Tite Grip Joint
- Extra Heavy Double Braced Legs
- Weight: 6.0kg (13lbs)

STAR HARDWARE SINGLE TOM STAND



HTS108W

- For up to 10" Depth Tom Tom
- 28.6mm Diameter Base Section Tubing
- Omni-Ball Tilter
- Glide-Tite Grip Joint
- True-Sound Insulation Mute
- Extra Heavy Double Braced Legs
- Oversized Rubber Feet with Retractable Spike
- Weight: 4.3kg (9.7lbs)

ROADRPO COMBINATION STAND



HTC807W

- 28.6mm Diameter Base Section Tubing
- Omni-Ball Tom Angle Adjustment / Movable Tom Positioning
- Quick-Set Tilter
- Quick-Set Cymbal Mate
- Glide-Tite Grip Joint
- Double Braced Legs
- Boom Arm Length: 300mm (11 3/4")
- Weight: 5.4kg (11.14lbs)

ROADRPO COMBINATION STAND



HTC87W

- 28.6mm Diameter Base Section Tubing
- Omni-Ball Tom Angle Adjustment
- Quick-Set Tilter
- Quick-Set Cymbal Mate
- Glide-Tite Grip Joint
- Double Braced Legs
- Boom Arm Length: 300mm (11 3/4")
- Weight: 5.5kg (12.2lbs)

ROADPRO DOUBLE TOM STAND



HTW839W

- 28.6mm Diameter Base Section Tubing
- Omni-Ball Tom Angle Adjustment
- Stilt System
- Glide-Tite Grip Joint
- Double Braced Legs
- Weight: 5.0kg (11lbs)

ROADPRO DOUBLE TOM STAND



HTW849W

- 28.6mm Diameter Base Section Tubing
- Omni-Ball Tom Angle Adjustment
- Glide-Tite Grip Joint
- Double Braced Legs
- Low Profile Tetrapod
- Weight: 5.1kg (11.3lbs)

STAGE MASTER DOUBLE TOM STAND



HTW49WN

- 25.4mm Diameter Base Section Tubing
- Omni-Ball Tom Angle Adjustment
- Double Braced Legs
- Weight: 3.6kg (7.14lbs)

NEW

THE CLASSIC TOM STAND



HTS58F

For 10" to 14" Diameter Drums
-19.1mm Diameter Base Section Tubing
-Flat Base Leg Design
-Classic Style Basket
-Single Braced Basket Arms
-Gearless Tilter
-Die-Cast Pipe Joint / Memory Lock
-Weight: 1.8kg (3.15lbs)
-Height Adjustment Range: 565mm (22 1/4") - 820mm (32 1/4")
-Storage size: 600mm (23 5/8") (upper section) / 410mm (16 1/8") (lower section)

DOUBLE TOM HOLDER



MTH1000

-25.4mm Diameter Bass Section Tubing
-Swivel-Wing Tom Holder

MTH1000 (chrome)
MTH1000BN (black nickel)
MTH1000U (smoked black nickel)

DOUBLE TOM HOLDER



MTH909

-25.4mm Diameter Bass Section Tubing
-Sliding Tom Adjustment

MTH909 (chrome)
MTH909BN (black nickel)

DOUBLE TOM HOLDER



MTH905N

-25.4mm Diameter Tubing
-Sliding Tom Adjustment

DOUBLE TOM HOLDER



MTH600

-25.4mm Diameter Tubing

MTH600 (chrome)
MTH600BN (black nickel)

SINGLE TOM HOLDER



MTH1000S

-25.4mm Diameter Bass Section Tubing
-Swivel-Wing Tom Holder

MTH1000S (chrome)
MTH1000SBN (black nickel)
MTH1000SU (smoked black nickel)

SINGLE TOM HOLDER



MTH900BS

-25.4mm Diameter Bass Section Tubing

SINGLE TOM HOLDER



MTH900BM

-25.4mm Diameter Tubing

HARDWARE KITS

We offer various hardware kit packages to complement any drum sets.

IRON COBRA 900 HARDWARE KIT



HG5WN

- HS800W Roadpro Snare Stand
- HC83BW Roadpro Boom Cymbal Stands (x2)
- HH905D Iron Cobra Hi-hat Stand
- HP900PN Iron Cobra Power Glide Single Pedal

IRON COBRA 200 HARDWARE KIT



HB5W

- HS60W Snare Stand
- HC63BW Boom Cymbal Stands (x2)
- HH205 Iron Cobra 200 Hi-hat Stand
- HP200P Iron Cobra 200 Single Pedal

STAGE MASTER HARDWARE KIT



SM5W

NEW

- HS40WN Stage Master Snare Stand
- HC43BWN Stage Master Boom Cymbal Stands (x2)
- HH205 Iron Cobra 200 Hi-hat Stand
- HP200P Iron Cobra 200 Single Pedal

THE CLASSIC STAND HARDWARE KIT



HC4FB

- HS50S Snare Stand
- HC52F Straight Cymbal Stands (x2)
- HH55F Hi-Hat Stand
- SBH01 Hardware Bag

POWER TOWER SYSTEM

TAMA's Power Tower System allows you to maintain the same precise set-up time after time. It utilizes 38.1mm stainless round pipes which allow for drums and hardware to be set-up at any angle quickly and easily.

POWER TOWER SYSTEM BASIC UNIT



PMD1100M

- 1100mm Curved Pipe (38.1mm diameter) x 1pc
- 850mm Straight Pipe (38.1mm diameter) w/19.1mm diameter Joint x 2pc
- 40mm x 20mm x 450mm Square Pipe x 2pc
- Leg Joint Bracket x 2pc
- Rubber Foot x 4pc
- Cross Joint Bracket (J30TS) x 2pc
- Multi Holder (J34T) x 2pc
- Memory Lock (A13S) x 4pc

POWER TOWER SYSTEM ADDITIONAL UNIT



PMD1100A

- 1100mm Curved Pipe (38.1mm diameter) x 1pc
- 850mm Straight Pipe (38.1mm diameter) w/19.1mm diameter Joint x 1pc
- 40mm x 20mm x 450mm Square Pipe x 1pc
- Leg Joint Bracket x 2pc
- Rubber Foot x 2pc
- Cross Joint Bracket (J30TS) x 2pc
- Multi Holder (J34T) x 1pc
- Memory Lock (A13S) x 3pc

POWER TOWER SYSTEM ADDITIONAL UNIT



PMD900A

- 900mm Curved Pipe (38.1mm diameter) x 1pc
- 850mm Straight Pipe (38.1mm diameter) w/19.1mm diameter Joint x 1pc
- 40mm x 20mm x 450mm Square Pipe x 1pc
- Leg Joint Bracket x 1pc
- Rubber Foot x 2pc
- Cross Joint Bracket (J30TS) x 2pc
- Multi Holder (J34T) x 1pc
- Memory Lock (A13S) x 3pc

CROSS JOINT BRACKET



J30TS

90 degree perpendicular pipe clamp that allows horizontal and vertical pipes to be set at an equal height.

MULTI HOLDER



J34T

Rack mount for L-rods, tom or cymbal holders. Fits pipes from 10.5mm to 28.6mm in diameter.

MEMORY LOCK



A13S

Memory clamp designed specifically for the Power Tower System.

SINGLE TOM HOLDER



MTH900BS

A single tom holder with 25.4mm diameter base tube.

CLAMPS AND ATTACHMENTS

Back in the 1970's TAMA's original introduction of the multi-clamp was a real revolution in the complex instrument we know as the drum kit. Today, multi-clamps are standard equipment in drums of all brands.

UNIVERSAL CLAMP

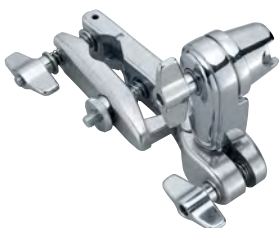

MC66

One side can hold pipes with diameters from 15.9mm to 28.6mm, while the other side is a ratchet holder that can hold a rod from 9mm to 12mm in diameter at various angles. An excellent clamp for adding an array of new set-up possibilities.

UNIVERSAL CLAMP

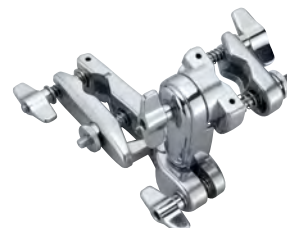

MC67

The heavier duty version of the MC66. One side holds pipes with diameters from 15.9mm to 28.6mm, while the other side is a ratchet holder that can hold a 12mm to 25.4 mm diameter rod or pipe at various angles.

MULTI-CLAMP

MC61

A basic clamp for connecting stands with pipes from 15.9mm to 28.6mm in diameter with any attachment having a 19.1mm diameter pipe.



MULTI-CLAMP

MC62

A double multi-clamp for connecting two pipes from 15.9mm to 28.6mm in diameter. Both sides feature the FastClamp Easy Set-Up System.



COMPACT CLAMP

MC5

A clamp for connecting parts with diameters of between 9mm to 12mm together. By combining a boom arm (MCB30EN, MCB45EN) and an L-rod (LLT, LCB, LCYE), this clamp can be used to attach a variety of parts onto a simple boom arm.



COMPACT CLAMP

MC7

Same function as the MC5, but with even greater flexibility. The ratchet holder section can hold any diameter tube from 12mm to 25.4mm.



HOOP GRIP

MC8

The Hoop Grip is a simple tool that allows you to add cymbals or other accessories to your drum kit to expand your setup and customize your sound with ease. The possibilities are endless!

-available on Steel Hoops and Die-Cast Hoops.
*NOT available on Wood Hoops.
*NOT recommended for Brass hoops.



Z-ROD FOR COWBELL

ZCB

Z-rod for mounting cowbell or other percussion instruments and accessories (9mm diameter)



Z-ROD FOR SPLASH CYMBAL -LONG

ZCYEL

Z-rod for mounting lightweight cymbals (10.5mm diameter)

Details:
-Quick-Set Cymbal Mate



Z-ROD FOR SPLASH CYMBAL -SHORT

ZCYE

Z-rod for mounting lightweight cymbals (10.5mm diameter)

Details:
-Quick-Set Cymbal Mate



ACCESSORY MOUNT ARM

HCA20

Accessory mount arm for mounting cymbals or accessories for snare drum effects (10.5mm diameter base section)



HOOP GRIP & ACCESSORY MOUNT ARM

MC8HCA20

Hoop Grip (MC8) & Accessory Mount Arm (HCA20) bundle package NEW



HOOP GRIP & Z-ROD FOR COWBELL



MC8ZCB

NEW

Hoop Grip (MC8) & Z-Rod for Cowbell (ZCB) bundle package

HOOP GRIP & Z-ROD FOR SPLASH CYMBAL



MC8ZCYE

NEW

Hoop Grip (MC8) & Z-Rod for Splash Cymbal (ZCYE) bundle package

HOOP GRIP & Z-ROD FOR SPLASH CYMBAL (LONG)



MC8ZCYEL

NEW

Hoop Grip (MC8) & Long Z-Rod for Splash Cymbal (ZCYEL) bundle package

CLOSED HI-HAT



MXA53

Simply designed closed hi-hat attachment that allows for two different settings by turning a lever. Attachable to stands from 15.9mm to 28.6mm in diameter. Great for double bass or double pedal players. And, you can also set up half open hi-hat cymbals by adjusting the spring.

CLOSED HI-HAT



MXA73N

This closed hi-hat attachment is ideal for double bass playing. The tension adjustment knob makes it possible to finely adjust the degree of opening of the hi-hat cymbals. In addition, the angle of the bottom cymbal is also adjustable, which allows for subtle adjustment of the sound of a closed or half-open hi-hat by changing how air escapes with each hit.

Details:

- Quick-set hi-hat clutch
- Quick-set tilter

L-ROD FOR TOM TOM



LLT

L-rod for mounting toms (10.5mm diameter).

L-ROD FOR COWBELL



LCB

L-rod for mounting different hand percussion instruments and accessories. The 9mm diameter rod fits most popular percussion instruments designed for attachment to a 3/8" rod.

L-ROD FOR CYMBAL



LCYE

L-rod for mounting lightweight cymbals.

Details:

- Quick-set cymbal mate

HAT STACK



CSH5

- Easily attach a small cymbal to hi-hat rod measuring up to 7mm in diameter
- Compact size and lightweight for easy transport and storage - 25mm (1") diameter x 40mm (1.5") height
- Ability to adjust cymbal sustain

CYMBAL STACKER



CSA15

The CSA15 is a straight-forward cymbal stacker useful for adding small cymbals to your setup using the M8 threaded cymbal rod.

CYMBAL STACKER



CSA25

The CSA25 allows positioning of a small cymbal on the M8 threaded cymbal rod, as well as independent angle adjustment.

RATCHET ARM



MRB30

The MRB30 features a 12mm rod for lighter duty usage.

Details:
- 300mm (11 3/4") length

RATCHET ARM



MTA30

The MTA30 ratchet arm features a 19.1mm pipe.

Details:
- 300mm (11 3/4") length

RATCHET ARM



MTA45

The MTA45 ratchet arm features a 19.1mm pipe.

Details:
- 450mm (17 3/4") length

BOOM ARM



MCB30EN

MCB30EN can be used in combination with a ratchet arm or the MC66 universal clamp is available.

Details:
- 300mm (11 3/4") length
- Quick-set tilter
- Quick-set cymbal mate

BOOM ARM



MCB45EN

MCB45EN can be used in combination with a ratchet arm or the MC66 universal clamp is available.

Details:
- 450mm (17 3/4") length
- Quick-set tilter
- Quick-set cymbal mate

CYMBAL HOLDER



CACLJ

NEW

Bass Drum Mounted Cymbal Holder features telescoping arm & fine gear tilter, which allow you to adjust the angle and height of the cymbal as you like in smaller spaces.

CYMBAL HOLDER



CA30EN

This cymbal holder with a pipe diameter of 19.1mm can be attached to stands using either the MC61 or MC62 multi-clamp.

The CA30EN is a professional-grade model equipped with a conversion function that allows the boom arm to be stored in the stand pipe and also includes the Quick-Set Tilter for convenient and easy set-up.

Details:
- 300mm (11 3/4") length
- Quick-set tilter
- Quick-set cymbal mate

CYMBAL HOLDER



CA45EN

This cymbal holder with a pipe diameter of 19.1mm can be attached to stands using either the MC61 or MC62 multi-clamp.

The CA45EN is a professional-grade model equipped with a conversion function that allows the boom arm to be stored in the stand pipe and also includes the Quick-Set Tilter for convenient and easy set-up.

Details:
- 450mm (17 3/4") length
- Quick-set tilter
- Quick-set cymbal mate

CYMBAL ATTACHMENT



CCA30

The assortment of boom cymbal holder and MC61 multi-clamp. By connecting to stands from 15.9mm to 28.6mm in diameter, you can add any cymbal easily.

CYMBAL ATTACHMENT



MCA53

The MCA53 is a simplified attachment based on the functionality of the MCA63EN. Add cymbals by securing this attachment to stands from 15.9mm to 28.6mm in diameter.

CYMBAL ATTACHMENT



MCA63EN

Combines the MC66 universal clamp and the MCB30EN boom arm. Works perfectly for adding cymbals and accessories to stands with pipes from 15.9mm to 28.6mm in diameter.

Details:
- Quick-set tilter
- Quick-set cymbal mate

CYMBAL ATTACHMENT



CYA5E

Combines the MC5 compact clamp with the LCYE L-rod for mounting one cymbal to one boom arm. Can be clamped to rods from 9mm to 12mm in diameter or to the L-rod of a tom holder.

Details: Quick-set cymbal mate

TOM ATTACHMENT



MC69

Clamping this attachment on a 15.9mm to 28.6mm diameter pipe allows for direct set-up of toms. Even with a compact construction, the inclusion of the Omni-ball feature at the angle adjustment point lets you adjust toms to any angle.

TOM ADAPTER



MTH900AS

This adapter allows you to add single toms to stands using the flexibility and speed of TAMA's Omni-Ball/L-rod combination.

COWBELL ATTACHMENT



CBA5

Compact attachment for mounting hand percussion such as cowbells or tambourines. Combines the MC5 compact clamp and the LCB L-rod to provide set-up flexibility. The 3/8" L-rod fits most popular percussion instruments and accessories.

COWBELL ATTACHMENT



CBA56

Combines the universal clamp with the LCB L-rod to mount most popular percussion instruments and accessories. Can be attached to pipes ranging from 15.9 mm to 28.6 mm in diameter.

COWBELL ATTACHMENT



CBH20

This simple attachment allows cowbells to be mounted on the bass drum. The length and angle of the L-rod can be easily changed for optimum positioning.

HI-HAT ATTACHMENT



MHA623

Connects the hi-hat to the hoop of a double bass drum so the hi-hat legs can be closed. An improved design featuring the Para-Clamp mechanism from the Iron Cobra pedal makes attachment even easier and more secure.

MICROPHONE STANDS

Just as many years ago, TAMA single-handedly altered the essence of the modern drum set through its re-invention of drum hardware—TAMA now turns that same degree of engineering dedication to yet another unevolved category of music gear: the microphone stand.

IRON WORKS STUDIO TELESCOPING BOOM STAND



MS736BK

- Vice-Grip Boom Tilter
- Iron-Core Legs with Vibration-Isolating Rubber Feet
- Iron-Core Telescoping Boom Arm
- Silent T-Handle
- Detachable Boom Arm
- Height: 975-1650mm (38 3/8"-64 15/16")
- Boom arm: 505-850mm (19 7/8"-33 7/16")
- Weight: 5.4kg (11.8 lbs)
- Black Finish

IRON WORKS STUDIO LOW PROFILE TELESCOPING BOOM STAND



MS736LBK

- Vice-Grip Boom Tilter
- Iron-Core Legs with Vibration-Isolating Rubber Feet
- Iron-Core Telescoping Boom Arm
- Silent T-Handle
- Detachable Boom Arm
- Height: 440mm – 605mm (17 5/16" – 23 13/16")
- Boom arm: 505mm – 850mm (19 7/8" – 33 7/16")
- Weight: 4.7kg (10.4lbs)
- Black Finish

IRON WORKS STUDIO ROUND BASE EXTRA LOW PROFILE TELESCOPING BOOM STAND



MS736RELBK

- Vice-Grip Boom Tilter
- Iron-Core Telescoping Boom Arm
- Silent T-Handle
- Detachable Boom Arm
- Heavy Round Cast Base
- Height: 280mm (11 1/32")
- Boom arm: 505mm – 850mm (19 7/8" – 33 7/16")
- Weight: 7.7kg (17.0lbs)
- Black Finish

IRON WORKS TOUR TELESCOPING BOOM STAND



MS436BK

- Cast Grip Boom Tilter
- Die-Cast Locking Thumb Nut
- Sure-Cast Adjustment Collar
- Iron-Core Telescoping Boom Arm
- Detachable Boom Arm
- Height: 985mm – 1660mm (38 3/4" – 65 3/8")
- Boom arm: 845mm (33 1/4")
- Weight: 3.9kg (8.6lbs)
- Black Finish

IRON WORKS TOUR LOW PROFILE TELESCOPING BOOM STAND



MS436LBK

- Cast Grip Boom Tilter
- Die-Cast Locking Thumb Nut
- Sure-Cast Adjustment Collar
- Iron-Core Telescoping Boom Arm
- Detachable Boom Arm
- Height: 440mm – 605mm (17 5/16" – 23 13/16")
- Boom arm: 505mm – 845mm (19 7/8" – 33 1/4")
- Weight: 3.1kg (6.8lbs)
- Black Finish

BOOM STAND



MS205

- Cast Grip Boom Tilter
- Die-Cast Locking Thumb Nut
- Height: 960mm – 1600mm (37 13/16" – 63")
- Boom arm: 830mm (32 11/16")
- Weight: 3.2kg (7.1 lbs)
- Chrome Finish

BOOM STAND



MS205BK

- Cast Grip Boom Tilter
- Height: 960mm – 1600mm (37 13/16" – 63")
- Boom arm: 830mm (32 11/16")
- Weight: 3.2kg (7.1 lbs)
- Black Finish

LOW PROFILE BOOM STAND



MS205ST

- Cast Grip Boom Tilter
- Height: 430mm – 560mm (17 1/8" – 22 1/16")
- Boom arm: 510mm (20 1/16")
- Weight: 2.3kg (5.1 lbs)
- Chrome Finish

LOW PROFILE BOOM STAND



MS205STBK

-Cast Grip Boom Tilter
Height: 430mm – 560mm (17 1/8"– 22 1/16")
Boom arm: 510mm (20 1/16")
Weight: 2.3kg (5.1 lbs)
Black Finish

STRAIGHT STAND



MS200BK

Height: 910 - 1550mm (36" - 61")
Weight: 2.4kg (5.4lbs)
Black Finish

STRAIGHT STAND WITH ROUND BASE



MS200DBK

-Cast Round Base with T-Bolt Pipe Fixing Device
Height: 895 - 1510mm (35 1/4" - 59 7/16")
Weight: 3.8kg (8.6lbs)
Black Finish

BOOM ARM



MS736BB

Vice-Grip Boom Tilter with Iron-Core Telescoping Boom Arm

BOOM ARM



MS436BB

Cast-Grip Boom Tilter with Iron-Core Telescoping Boom Arm

CORD CLIP



CC5

For 15.9 mm (5/8") diameter tube.

CORD CLIP



CC7

For 22.2 mm (7/8") diameter tube.

DIE-CAST LOCKING THUMB NUT



DTLN3

For 3/8" connector
Not only does the thumb nut's larger, sure-grip design allow greater leverage for faster, easier set-up and breakdown, its high quality zinc threads and walls are built to handle pressure for years to come.

RUBBER FOOT



756-RF

TAMA's extra thick rubber foot covers "float" the stand, isolating the microphone from floor vibrations. (for 19.1mm diameter leg)

TAMA PERCUSSION

For more than 40 years, TAMA has been inspiring drummers around the world with its unique range of original percussion instruments. Combining the influences of global musical cultures with modern technology, TAMA has given drummers and percussionists of every genre a new lease on creativity with the unique voices these instruments provide.

GONG BASS DRUM



BG20R

MADE IN JAPAN

14"x20" Starclassic Bubinga Gong Bass Drum

An early TAMA original, the Gong Bass Drum uses a 22" head mounted Tympa style on a 20" shell with no bottom head. This design produces a thunderous, low-end sound with excellent sustain, characteristic of the large Taiko drums of ancient Japan. The Gong Bass uses a 8mm thick Starclassic Bubinga shell, and is fitted with chrome hardware.

*Gong Bass Drums is available in Piano Black (PBK) finish only.

STEEL MINI-TYMP



MT68ST

4"x6" + 4"x8"

Steel Mini-Tymp come with an L-rod (LLT) and multi-clamp (MC66).

STEEL MINI-TYMP



MT810ST

4"x8" + 4"x10"

Steel Mini-Tymp come with an L-rod (LLT) and multi-clamp (MC66).

STEEL MINI-TYMP



MT1012ST

4"x10" + 4"x12"

Steel Mini-Tymp come with an L-rod (LLT) and multi-clamp (MC66).

JINGLE RING



TJR7

The Jingle Ring is a slim tambourine that can be mounted on a hi-hat stand or as a separate item. It features 9 pairs of nickel "jingles" that produce a bright, clear, tambourine sound. Its eyebolt style clamp secures it firmly in place for playing, and allows mounting of the Jingle Ring to the hi-hat rod or the 8mm diameter rod of a boom arm.

SONIC COWBELL



TSC4

4" Cowbell

SONIC COWBELL



TSC6

6" Cowbell

OCTOBAN SET



7850N2H

2pc High-pitch set w/HOW29WN stand

OCTOBAN SET



7850N2L

2pc Low-pitch set w/HOW29WN stand

OCTOBAN SET



7850N4H

4pc High-pitch set w/HOW49WN stand

OCTOBAN SET



7850N4L

4pc Low-pitch set w/HOW49WN stand

OCTOBAN



OCT280N

280mm (11") depth

OCTOBAN



OCT301N

301mm (11 3/4") depth

OCTOBAN



OCT343N

343mm (13 1/2") depth

OCTOBAN



OCT390N

390mm (15 1/2") depth

OCTOBAN



OCT443N

443mm (17 1/2") depth

OCTOBAN



OCT472N

472mm (18 1/2") depth

OCTOBAN



OCT536N

536mm (21") depth

OCTOBAN



OCT600N
600mm (23 1/2") depth

OCTOBAN STAND



HOW29WN
for 2pcs octobans

OCTOBAN STAND



HOW49WN
for 4pcs octobans

OCTOBAN HOLDER FOR DRUM RACK



OA29
for 2pcs octobans

OCTOBAN HOLDER FOR DRUM RACK



OA49
for 4pcs octobans

PRACTICE TOOLS

Our unique practice tools make your percussive education more enjoyable and productive.

PRACTICE PAD



TMP8S
This snare pad is an actual 4" x 8" inch drum with a mesh head. It has a half cut snare wire facing the backside of the mesh head from inside the drum. The knurled knob on the side of the shell lets you adjust the snare tension from tight to loose and off. You can also adjust the tension of the mesh as on a conventional drum.

PRACTICE PAD



TSP6
The special urethane foam on this pad provides a nice bouncy feel for more enjoyable and more productive practice. The six-inch diameter size also makes it easily portable.

PRACTICE PAD STAND



HS40TPN

NEW

The HS40TPN practice pad stand can hold pads between 6 and 10 inches in diameter. The rubber cushions on the basket can also be reversed to hold smaller pads more securely. As well, the EP222 Extension Pipe (sold separately) enables you to practice comfortably in a standing position.

-Single Braced Legs
-Height Adjustment Range
w/o extension pipe: 580mm - 710mm (22 13/16" - 27 15/16")
w/ extension pipe: 790mm - 1,065mm (31 1/8" - 41 15/16")
*Measured from the top surface of a 10 inch training pad to the floor

EXTENSION PIPE FOR PRACTICE PAD STAND



EP222

NEW

The height of the HS40TPN can be easily extended by attaching the EP222 extension pipe between the upper and lower section of unit. No tools are required to install this product.

MESH HEAD



MH8T

MH8T (8")
MH10T (10")
MH12T (12")
MH13T (13")
MH14T (14")
MH16T (16")
MH18B (18")
MH22B (22")

CYMBAL MUTE



CM14HH

for 14" hi-hat cymbal

CYMBAL MUTE



CM1416

for 14" or 16" cymbal

CYMBAL MUTE



CM1820

for 18" or 20" cymbal

SILENT PRACTICE SET



SPP518C

Mesh head for 18" bass drum
Mesh head for 10" tom tom
Mesh head for 12" tom tom
Mesh head for 14" floor tom
Mesh head for 13" snare drum
Cymbal mute for 14" hi-hat cymbal
Cymbal mute for 14" or 16" cymbal

SILENT PRACTICE SET



SPP522C

Mesh head for 22" bass drum
Mesh head for 12" tom tom
Mesh head for 13" tom tom
Mesh head for 16" floor tom
Mesh head for 14" snare drum
Cymbal mute for 14" hi-hat cymbal
Cymbal mute for 14" or 16" cymbal
Cymbal mute for 18" or 20" cymbal

SILENT PRACTICE SET



SPP522KC

Mesh head for 22" bass drum
Mesh head for 10" tom tom
Mesh head for 12" tom tom
Mesh head for 16" floor tom
Mesh head for 14" snare drum
Cymbal mute for 14" hi-hat cymbal
Cymbal mute for 14" or 16" cymbal
Cymbal mute for 18" or 20" cymbal

SILENT TIPS



TCP20

TAMA TCP20 is a pair of silicone rubber tips that fit over most drum stick models. These tips make it easy and convenient to practice silently, anytime, anywhere.

BAGS

TAMA's heavy duty bags protect your drums from damage during transportation.

POWERPAD BAG -Tom Tom-



PBT8

PBT8 (7"x8" Tom Tom)
 PBT10 (8"x10" Tom Tom)
 PBT12 (9"x12" Tom Tom)
 PBT13 (10"x13" Tom Tom)
 PBT14 (11"x14" Tom Tom)

- Durable four layered structure to protect the drum in transportation
- Easy-to-understand size tags
- A soft fur material to protect scratching

POWERPAD BAG -Floor Tom-



PBF14

PBF14 (14"x14" Floor Tom)
 PBF16 (16"x16" Floor Tom)

- Durable four layered structure to protect the drum in transportation
- Easy-to-understand size tags
- A soft fur material to protect scratching

POWERPAD BAG -Bass Drum-



PBB18

PBB18 (16"x18" Bass Drum or Floor Tom)
 PBB20 (18"x20" Bass Drum)
 PBB22 (18"x22" Bass Drum)
 PBB22X (20"x22" Bass Drum)
 PBB24 (18"x24" Bass Drum)

- Durable four layered structure to protect the drum in transportation
- Easy-to-understand size tags
- A soft fur material to protect scratching

POWERPAD BAG -Snare Drum-



PBS1455

PBS1455 (5.5"x14" Snare Drum)
 PBS1465 (6.5"x14" Snare Drum)
 PBS1480 (8"x14" Snare Drum)

- Durable four layered structure to protect the drum in transportation
- Easy-to-understand size tags
- A soft fur material to protect scratching

POWERPAD DESIGNER BAG -Snare Drum-



TSDB1465BK

NEW

Black
 6.5"x14" Snare Drum

- Convertible Backpack Straps
- 20mm thick semi-hard cushion
- Backpack Straps and ergonomic rubber handle

POWERPAD DESIGNER BAG -Snare Drum-



TSDB1465BE

NEW

Beige
 6.5"x14" Snare Drum

- Convertible Backpack Straps
- 20mm thick semi-hard cushion
- Backpack Straps and ergonomic rubber handle

POWERPAD DESIGNER BAG -Snare Drum-



TSDB1465NB

NEW

Navy Blue
 6.5"x14" Snare Drum

- Convertible Backpack Straps
- 20mm thick semi-hard cushion
- Backpack Straps and ergonomic rubber handle

POWERPAD DESIGNER BAG -Snare Drum-



TSDB1465WR

NEW

Wine Red
 6.5"x14" Snare Drum

- Convertible Backpack Straps
- 20mm thick semi-hard cushion
- Backpack Straps and ergonomic rubber handle

POWERPAD BAG -Hardware-



PBH02L

880 (L) x150 (W) x200 (H) mm
(34 5/8" x 5 7/8" x 7 7/8")

-Suitable size for storing about 5 stand

POWERPAD BAG -Hardware-



PBH05

850 (L) x 320 (W) x220 (H) mm
(33 1/2" x 12 5/8" x 8 5/8")

-Suitable size for storing about 10 stands
-Equipped with durable wheels

POWERPAD BAG -Cymbal-



PBC22

The POWERPAD® Series Cymbal Bag is a heavy duty bag designed to carry cymbals up to 22" in diameter. The front side pocket is great for hi-hat cymbals (up to 15") or a splash cymbal. The back side pocket is designed for accessory storage. In addition, the main compartment contains (3) 22" dividers and the front side pocket contains (3) 15" dividers.

POWERPAD DESIGNER BAG -Cymbal-



TCB22BK

NEW

Black
up to 22" Cymbal + 15" Cymbal (front side pocket)

-20mm thick semi-hard cushion
-Padded shoulder Straps and handle
-22" compartment dividers (3pcs) and 15" compartment dividers (3pcs) included

POWERPAD DESIGNER BAG -Cymbal-



TCB22BE

NEW

Beige
up to 22" Cymbal + 15" Cymbal (front side pocket)

-20mm thick semi-hard cushion
-Padded shoulder Straps and handle
-22" compartment dividers (3pcs) and 15" compartment dividers (3pcs) included

POWERPAD DESIGNER BAG -Cymbal-



TCB22NB

NEW

Navy Blue
up to 22" Cymbal + 15" Cymbal (front side pocket)

-20mm thick semi-hard cushion
-Padded shoulder Straps and handle
-22" compartment dividers (3pcs) and 15" compartment dividers (3pcs) included

POWERPAD DESIGNER BAG -Cymbal-



TCB22WR

NEW

Wine Red
up to 22" Cymbal + 15" Cymbal (front side pocket)

-20mm thick semi-hard cushion
-Padded shoulder Straps and handle
-22" compartment dividers (3pcs) and 15" compartment dividers (3pcs) included

POWERPAD BAG -Twin Pedal-



PBP200

The POWERPAD® Series bag lineup includes the PBP200 double pedal bag. The PBP200 can accommodate both single and double pedals. The PBP200 bag has a shoulder pad built into the strap for comfort. There is also a special pocket for your double pedal's connecting rod inside the bag.

450 (L) x300 (W) x 200 (H) mm
(17 3/4" x 11 3/4" x 7 7/8")

POWERPAD BAG -Single Pedal-



PBP100

The POWERPAD® Series bag for single pedal.

220 (D) x190 (W) x 400 (H) mm
(8 5/8" x 7 1/2" x 15 3/4")

POWERPAD BAG -Drum Throne-



PBTH15

-Carries any TAMA drum throne
-Carries 14" snare drum and snare drum stand
-Shoulder strap and handle for easy transportation

POWERPAD BAG -Stick & Mallet-



PBS50

Stores about 24 pairs of sticks & mallets

- Large front pocket for sheet music
- Built-in hooks easily attach to floor tom
- Padded Shoulder strap
- Convenient inner pockets
- Height: 500mm
- Open Width: 580mm

POWERPAD DESIGNER BAG -Stick-



TSB24BK

NEW

Black
Stores about 12 pairs of sticks

- Main pockets for 12 pairs of sticks, and side pockets for accessories
- Built-in hooks easily attach to floor tom
- Shoulder strap for portability
- Convenient inner pockets
- Size: 460mm x 180mm
- Side Pocket: 260mm x 160mm

POWERPAD DESIGNER BAG -Stick-



TSB24BE

NEW

Beige
Stores about 12 pairs of sticks

- Main pockets for 12 pairs of sticks, and side pockets for accessories
- Built-in hooks easily attach to floor tom
- Shoulder strap for portability
- Convenient inner pockets
- Size: 460mm x 180mm
- Side Pocket: 260mm x 160mm

POWERPAD DESIGNER BAG -Stick-



TSB24NB

NEW

Navy Blue
Stores about 12 pairs of sticks

- Main pockets for 12 pairs of sticks, and side pockets for accessories
- Built-in hooks easily attach to floor tom
- Shoulder strap for portability
- Convenient inner pockets
- Size: 460mm x 180mm
- Side Pocket: 260mm x 160mm

POWERPAD DESIGNER BAG -Stick-



TSB24WR

NEW

Wine Red
Stores about 12 pairs of sticks

- Main pockets for 12 pairs of sticks, and side pockets for accessories
- Built-in hooks easily attach to floor tom
- Shoulder strap for portability
- Convenient inner pockets
- Size: 460mm x 180mm
- Side Pocket: 260mm x 160mm

POWERPAD BAG -Stick-



PBS24

Stores about 12 pairs of sticks & mallets

The POWERPAD® Series Stick Bag is designed to be easy and convenient, and comes standard with both a handle grip and shoulder strap. For mounting the bag onto your set, built-in hooks fit easily onto the floor tom tension rods. The inner pocket is designed to hold two pairs of sticks, which makes grabbing a fresh stick while playing easier than ever.

POWERPAD BAG -Stick-



TSB12BK

Black
Stores about 6 pairs of sticks

- Top of the bag open to take out stick easily
- Elastic band easily attach to floor tom
- Convenient inner pockets

POWERPAD BAG -Stick-



TSB12DBK

NEW

Black Denim
Stores about 6 pairs of sticks

- Top of the bag open to take out stick easily
- Eye-catching design and color choices featuring Denim fabrics
- Elastic band easily attach to floor tom
- Convenient inner pockets

POWERPAD BAG -Stick-



TSB12NB

Navy Blue
Stores about 6 pairs of sticks

- Top of the bag open to take out stick easily
- Elastic band easily attach to floor tom
- Convenient inner pockets

POWERPAD BAG -Stick-



TSB12DBL

NEW

Blue Denim
Stores about 6 pairs of sticks

- Top of the bag open to take out stick easily
- Eye-catching design and color choices featuring Denim fabrics
- Elastic band easily attach to floor tom
- Convenient inner pockets

POWERPAD BAG -Stick-



TSB12BE

Beige
Stores about 6 pairs of sticks

- Top of the bag open to take out stick easily
- Elastic band easily attach to floor tom
- Convenient inner pockets

POWERPAD BAG -Stick-



TSB12WR

Wine Red
Stores about 6 pairs of sticks

- Top of the bag open to take out stick easily
- Elastic band easily attach to floor tom
- Convenient inner pockets

LZ SERIES STICK BAG



LZ-STB01BK

Stores about 12 pairs of sticks & mallets

LZ Series Stick Bags are smartly designed featuring leather-like PVC combined with real calf skin. They come equipped with inner and outer pockets as well as hooks for attachment to the floor tom tension rods.

LZ SERIES STICK BAG



LZ-STB02BK

Stores about 6 pairs of sticks

LZ Series Stick Bags are smartly designed featuring leather-like PVC combined with real calf skin. They come equipped with inner and outer pockets as well as hooks for attachment to the floor tom tension rods.

STANDARD SERIES DRUM BAG SET



DSS52K

18"x22"BD
8"x10"TT
9"x12"TT
16"x16"FT
6.5"x14"SD

- 600 denier high density water resister surface
- Water resistant nylon with 10mm thick cushion
- Ergonomic rubber handles
- Carrying strap with shoulder pads (except Bass drum bag)
- Tom bags accommodate drums with Star-cast mounts

STANDARD SERIES DRUM BAG SET



DSS52H

18"x22"BD
6.5"x10"TT & 7"x12"TT (1bag)
16"x16"FT
6.5"x14"SD

- 600 denier high density water resister surface
- Water resistant nylon with 10mm thick cushion
- Ergonomic rubber handles
- Carrying strap with shoulder pads (except Bass drum bag)
- Tom bags accommodate drums with Star-cast mounts

STANDARD SERIES DRUM BAG SET



DSS50S

18"x20"BD
8"x10"TT
9"x12"TT
14"x14"FT
6.5"x14"SD

- 600 denier high density water resister surface
- Water resistant nylon with 10mm thick cushion
- Ergonomic rubber handles
- Carrying strap with shoulder pads (except Bass drum bag)
- Tom bags accommodate drums with Star-cast mounts

STANDARD SERIES DRUM BAG SET



DSS62S

18"x22"BD
8"x10"TT
9"x12"TT
14"x14"FT
16"x16"FT
6.5"x14"SD

- 600 denier high density water resister surface
- Water resistant nylon with 10mm thick cushion
- Ergonomic rubber handles
- Carrying strap with shoulder pads (except Bass drum bag)
- Tom bags accommodate drums with Star-cast mounts

STANDARD SERIES DRUM BAG SET



DSS62H

18"x22"BD
6.5"x10"TT & 7"x12"TT (1bag)
14"x14" FT
16"x16"FT
6.5"x14"SD

- 600 denier high density water resister surface
- Water resistant nylon with 10mm thick cushion
- Ergonomic rubber handles
- Carrying strap with shoulder pads (except Bass drum bag)
- Tom bags accommodate drums with Star-cast mounts

STANDARD SERIES DRUM BAG SET



DSS48LJ

(for Club-JAM kit)
12"x18" BD
8"x10" TT
7"x14" FT & 5"x13" SD (1bag)

- 600 denier high density water resister surface
- Water resistant nylon with 10mm thick cushion
- Ergonomic rubber handles
- Carrying strap with shoulder pads (except Bass drum bag)

STANDARD SERIES DRUM BAG SET



DSS28LJ

NEW

(for Club-JAM MINI kit)
17"x18" BD
5"x12" SD

- 600 denier high density water resister surface
- Water resistant nylon with 10mm thick cushion
- Ergonomic rubber handles
- Carrying strap with shoulder pads

STANDARD SERIES DRUM BAG SET



DSS48S

14"x18" BD
9"x12" TT
14"x14" FT
6.5"x14" SD

- 600 denier high density water resister surface
- Water resistant nylon with 10mm thick cushion
- Ergonomic rubber handles
- Carrying strap with shoulder pads (except Bass drum bag)
- Tom bags accommodate drums with Star-cast mounts

STANDARD SERIES DRUM BAG SET



DSS72S

18"x22" BD
7"x8" TT
8"x10" TT
9"x12" TT
14"x14" FT
16"x16" FT
6.5"x14" SD

- 600 denier high density water resister surface
- Water resistant nylon with 10mm thick cushion
- Ergonomic rubber handles
- Carrying strap with shoulder pads (except Bass drum bag)
- Tom bags accommodate drums with Star-Cast mounts

STANDARD SERIES SNARE BAG



SBS14

6.5"x14" Snare Drum

- 600 denier high density water resister surface
- Water resistant nylon with 10mm thick cushion
- Ergonomic rubber handles
- Carrying strap with shoulder pads

STANDARD SERIES CAJON BAG



SBC01

NEW

Size: 520 (L) x 310 (W) x 330 (H) mm
Side Pocket: 520 (L) x 50 (W) x 330 (H) mm

- Designed for smooth extraction and insertion of Cajon
- 600 denier high density water resister surface
- Water resistant nylon with 10mm thick cushion
- Carrying strap with shoulder pad
- Utility side pocket for hand percussion, accessories etc.

STANDARD SERIES HARDWARE BAG



SBH01

(for Compact / Lightweight Hardware)
670 (L) x180 (W) x190 (H) mm
(26 2/5" x 7 1/10" x 7 1/2")

- 600 denier high density water resister surface
- Water resistant nylon with 10mm thick cushion
- Carrying strap with shoulder pads

STANDARD SERIES MICROPHONE STAND BAG



SBM01

NEW

Stores up to 6 pcs of Microphone Stands or 2pcs of Speaker Stands
1200 (L) x 220 (W) x 200 (H) mm

- 600 denier high density water resister surface
- Water resistant nylon with 10mm thick cushion
- Carrying strap with shoulder pad

ACCESSORIES

We offer many unique accessories to enhance your playing, set up, and tone of the drums.

RHYTHM WATCH



RW200

Tempo Range: 30-250 BPM
 Tempo, Beat & Sound Memory: 30 Songs
 Beats: 0-9
 Display: LCD with BACK LIGHT
 Size: 127 x 35 x 150mm (5" x 1.4" x 6")
 Weight: 285g including battery
 Power Supply: 9V Battery (S-006P) or DC9V 200mA adapter

RHYTHM WATCH MINI



RW30

Tempo Range: 30-250 BPM
 Beats: 0-9
 Display: LCD display with BACK LIGHT
 Size: 61 x 25 x 118mm (2 1/2" x 1" x 4 5/8")
 Weight: 90g including battery
 Power Supply: 2 x AAA Batteries (3V)

RHYTHM WATCH HOLDER



RWH10

for RW200

TENSION WATCH



TW200

The TW200 TAMA Tension Watch is very compact and is equipped with an easy-to-read dial. It comes with a detachable nylon bumper to ensure consistent measuring distance from the hoop, resulting in an evenly tensioned drum for the best sound.

TENSION WATCH CARRYING BAG



TW2B

This bag is specially designed to carry the TW200 Tension Watch safely and securely.

TENSION WATCH



TW100

The TW100 measures actual head tension and features an easy-to-read meter, so you can record the numbers and duplicate your best tuning time after time. You can also use the sample tunings suggested in the directions.

DRUMMER'S GLOVE



TDG10BKL

NEW

Drummer's Glove with featuring extra soft and durable synthetic leather which prevents any slipping while playing even with wet condition caused by sweating. The stretch mesh material utilized on the top provides excellent breathability.

Black
 TDG10BKM (Medium)
 TDG10BKL (Large)

DRUMMER'S GLOVE



TDG10WHL

NEW

Drummer's Glove with featuring extra soft and durable synthetic leather which prevents any slipping while playing even with wet condition caused by sweating. The stretch mesh material utilized on the top provides excellent breathability.

White
 TDG10WHM (Medium)
 TDG10WHL (Large)

WOOD HOOP PROTECTOR



WHP2

(2pcs / set)
Special adhesive pieces protect your wood hoop from being scratched by preventing the bass drum pedal from twisting or slipping.

MULTI TOOL



TMT9

Quick access multi tool for drums
-Hex Wrench 5.0mm/4.0mm/3.0mm/2.5mm/
2.0mm, Keychain Link, Hex Nut Driver, Phillips
Screwdriver, Drum Keys (x2)

DRUM RUG -Oriental Pattern-



TDR-OR

1800mm x 2000mm
(70 7/8" x 78 3/4")

-Non-slip design helps keep drums & hardware in place
-Extra-large size accommodates most drum setups
-Hook and loop fasteners for easy transport

DRUM RUG -TAMA Logo Pattern-



TDR-TL

1800mm x 2000mm
(70 7/8" x 78 3/4")

-Non-slip design helps keep drums & hardware in place
-Extra-large size accommodates most drum setups
-Hook and loop fasteners for easy transport

STAND WEIGHT



TSW10

TAMA hardware is highly regarded for its quality and stability. But sometimes you need a little extra stability – either for extremely hard hitting, or if the playing surface is uneven. To meet that need, we present TAMA Stand Weights, which enable you to stabilize your stand firmly on any surface simply by looping the weight around the tripod base.
Weight: 3kg (6.6lb)

REMO FIBERSKYN POWERSTROKE 3 DIPLOMAT



RF22BMST

(TAMA Logo)
RF18BMST (18")
RF20BMST (20")
RF22BMST (22")
RF24BMST (24")
RF26BMST (26")

WHITE COATED HEADS



CT22BMOT

(TAMA & Starclassic Logo)
CT18BMOT (18")
CT20BMOT (20")
CT22BMOT (22")
CT24BMOT (24")
CT26BMOT (26")

FIBER LAMINATED HEADS



FB22BMFS

(TAMA & Starclassic Logo)
FB18BMFS (18")
FB20BMFS (20")
FB22BMFS (22")
FB24BMFS (24")

BLACK HEADS



BK22BMTT

(TAMA & Starclassic Logo)
BK18BMTT (18")
BK20BMTT (20")
BK22BMTT (22")
BK24BMTT (24")
BK26BMTT (26")

SMOOTH WHITE HEADS



SW22BMTT

(TAMA & Starclassic Logo)
SW20BMTT (20")
SW22BMTT (22")
SW24BMTT (24")

FIBER LAMINATED HEADS -BLACK-



BK22BMFH

(TAMA Logo for Superstar Hyper-Drive)
BK20BMFH (20")
BK22BMFH (22")
BK24BMFH (24")

WHITE COATED HEADS -TAMA LOGO-



CT22BMSV

(TAMA Logo)
CT18BMSV (18")
CT20BMSV (20")
CT22BMSV (22")
CT24BMSV (24")

BLACK HEADS -TAMA LOGO-



BK22BMWS

(TAMA Logo)
BK20BMWS (20")
BK22BMWS (22")
BK24BMWS (24")

DIE-CAST HOOPS



MDH14-10

Made of die-cast zinc, TAMA's die-cast hoops deliver an incredibly sharp, solid rim shot that cannot be found in any other hoop.

MDH13-8 (13" 8 hole batter side)
MDH13S-8 (13" 8 hole snare side)
MDH14-8 (14" 8 hole batter side)
MDH14S-8 (14" 8 hole snare side)
MDH14-10 (14" 10 hole batter side)
MDH14S-10 (14" 10 hole snare side)

CUSTOMIZED BRASS MIGHTY HOOPS

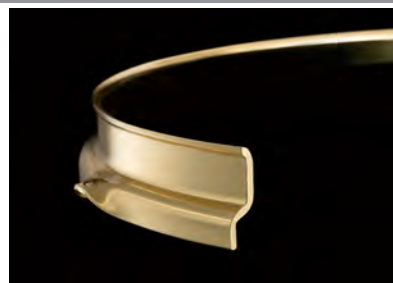

MSP14-8

NEW

Customized Brass Mighty Hoop provides a sharper and brighter attack with rich harmonic overtones, made of brass with a slightly shaved down edge.

MSP14-8 (14" 8 hole batter side)
MSP14S-8 (14" 8 hole snare side)

MAPLE WOOD HOOPS



WMH1410B

Wood Hoop provides a warm, woody sound with soft attack. Can be mounted on a standard 14" snare drum stand.

WMH1408B (14" 8 hole batter side)
WMH1408S (14" 8 hole snare side)
WMH1410B (14" 10 hole batter side)
WMH1410S (14" 10 hole snare side)

2.3mm BRASS MIGHTY HOOPS

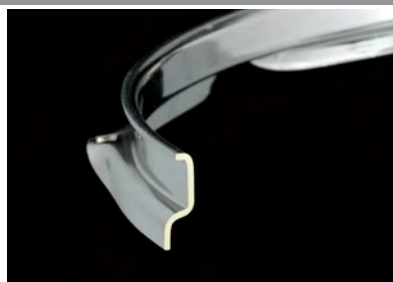

MFB14-10N

Brass Mighty Hoop provides a warm and open sound with mild attack and long sustain.

MFB14-10N (14" 10 hole batter side)
MFB14S-10N (14" 10 hole snare side)

2.3mm STEEL MIGHTY HOOPS

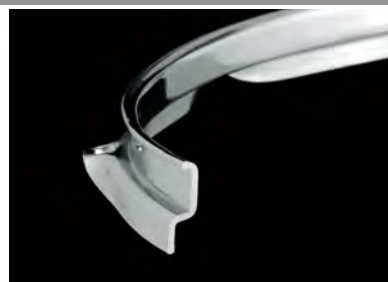

MFM14-10

Steel Mighty Hoop provides a bright and open sound.

MFM14-8 (14" 8 hole batter side)
MFM14S-8 (14" 8 hole snare side)
MFM14-10 (14" 10 hole batter side)
MFM14S-10 (14" 10 hole snare side)

2.3mm SOUND ARC HOOPS



MSH1410

Steel Sound Arc Hoop enhances the natural tone of the snare drum and offers sensitivity, precise tuning, and control.

MSH1410 (14" 10 hole batter side)
MSH14S10 (14" 10 hole snare side)

2.3mm BRASS SOUND ARC HOOPS

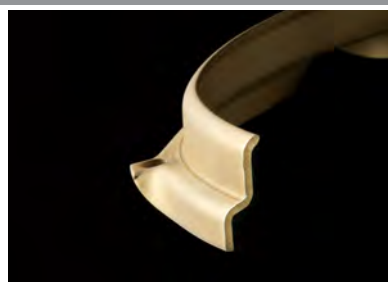

MSB148D

Brass Sound Arc Hoop provides an open sound with rich harmonic overtones, made of brass with an inward curved shape.

MSB148D (14" 8 hole batter side)
MSB14S8D (14" 8 hole snare side)

DRUM KEY

TDK10BN

Black Nickel



DRUM KEY

TDK10

Chrome



DRUM KEY

6560R



TENSION LOCK

TTL10

(10pcs/set)



The Tension Lock is an accessory to prevent tension bolts from loosening while playing. Simply set it on the tension bolt head – its unique shape fits perfectly. On the other hand, you can tune the drum without having to detach the Tension Lock, thanks to an elastic O-ring around its hole. It is a small accessory, but filled with TAMA's unique ideas.

SUPER SENSITIVE HI-CARBON SNARE WIRES

MS20RL14C

In order to provide a more crisp and sensitive sound, we redesigned our Snare Wires using new materials, customizing the shape of the plate, and changing the wire coils' winding pattern. As a result, the new "Super Sensitive Hi-Carbon Snare Wire" fits more closely to the snare side head, providing greater sensitivity and brighter, crisper sound.



MS20RL13C (13" 20 strands Hi-Carbon Steel)
MS20RL14C (14" 20 strands Hi-Carbon Steel)

SUPER SENSITIVE HI-CARBON SNARE WIRE FOR CONCERT

MS20L14C8

A thin brass plate and softer hi-carbon coils respond to even the softest touch on the edge of the batter head.

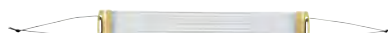

MS20L14C8 (14" 20 strands Hi-Carbon Steel)

STAINLESS STEEL STRAIGHT SNARE WIRE

MS20M14ST

20 strands steel straight wire for concert. Extra short sustain, dark and crisp.



MS20M14ST (14" 20 strands Steel)

STARCLASSIC SNARE WIRES -CARBON STEEL-

MS20SN14S

Starclassic snares offer several unique, highly useful features. When adding more tension to the wires, the strands press closer to the snare head. We've also redesigned the angle of the end plates and added thinner straps to obtain optimum response.



MS20SN10S (10" 20 strands Carbon Steel)
MS20SN12S (12" 20 strands Carbon Steel)
MS20SN13S (13" 20 strands Carbon Steel)
MS20SN14S (14" 20 strands Carbon Steel)

STARCLASSIC SNARE WIRES -BELL BRASS-

MS20SN14B

Starclassic snares offer several unique, highly useful features. When adding more tension to the wires, the strands press closer to the snare head. We've also redesigned the angle of the end plates and added thinner straps to obtain optimum response. The MS20SN14B features bell brass strands for greater sensitivity.



MS20SN14B (14" 20 strands Bell Brass)

STARCLASSIC SNARE WIRES -HI-CARBON STEEL-

MS20SN14C

Starclassic snares offer several unique, highly useful features. When adding more tension to the wires, the strands press closer to the snare head. We've also redesigned the angle of the end plates and added thinner straps to obtain optimum response.



MS20SN13C (13" 20 strands Hi-Carbon Steel)
MS20SN14C (14" 20 strands Hi-Carbon Steel)

REGULAR SNARE WIRES -CARBON STEEL-

MS12R14S

(14" 12 strands Carbon Steel)

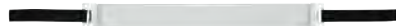

REGULAR SNARE WIRES -CARBON STEEL-

MS20R14S

(14" 20 strands Carbon Steel)



REGULAR SNARE WIRES -CARBON STEEL-

MS30R14S

(14" 30 strands Carbon Steel)



REGULAR SNARE WIRES -CARBON STEEL-

MS42R14S

(14" 42 strands Carbon Steel)



REGULAR SNARE WIRES -HI-CARBON STEEL-

MS42R14C

(14" 42 strands Hi-Carbon Steel)



HOLD TIGHT™ WASHERS

SRW620P

(20pcs/set)

The rubber rings inside of the cup-shaped stainless steel washers absorb impact vibrations and keep the hoop and tension bolts in constant contact to prevent from loosening of tension.



PLASTIC WASHERS

PW620

(20pcs/set)

2.5mm thick nylon washers decrease noise and make tuning easier and more stable.



METAL WASHERS

MW620

(20pcs/set)

Standard metal tension bolt washers.



SNARE WIRE STRAPS

MST20

(2pcs/set)

These flexible yet durable 15mm wide nylon snare wire straps are featured on most of TAMA snare drums.



SNARE WIRE STRINGS

SPC50P4

(2prs/pack)

The amazingly durable and flexible snare wire string is made of Dupont Kevlar® cable wrapped in polyester fiber for an even higher tensile strength than steel wire. (Kevlar® is a registered trademark of Dupont® Corporation.)



DRUM CLEANING CLOTH



TDC1000

TAMA TDC1000 features two distinct surfaces (the material made in JAPAN by UNITIKA TRADING CO., LTD.). Flat fiber surface is designed for the hardware and cymbal. Soft fiber surface excels at dry cleaning for daily Drum care needs.

POWER-STRIKE COBRA BEATER



CB900PS

Felt

ACCU-STRIKE COBRA BEATER



CB900AS

Rubber

PROJECTOR BEATER



PB90F

Felt

COBRA BEATER -Felt-



CB90F

Felt

COBRA BEATER -Rubber-



CB90R

Rubber

COBRA BEATER -Wood-



CB90W

Wood

POWER-STRIKE COBRA BEATER HEAD



CB900PSH

Felt

ACCU-STRIKE COBRA BEATER HEAD



CB900ASH

Rubber

PROJECTOR BEATER HEAD



PB90FH

Felt

COBRA BEATER HEAD -Felt-



CB90FH

Felt

COBRA BEATER HEAD -Rubber-



CB90RH

Rubber

COBRA BEATER HEAD -Wood-



CB90WH

Wood

DUAL SIDED BEATER -Felt-



DS30

Felt

DUAL SIDED BEATER -Felt-



DS30G

Felt

DUAL SIDED BEATER -Rubber-



DS30R

Rubber

THE CLASSIC BEATER -Felt-



CLB30F

Felt

TRADITIONAL BEATER -Felt-



TTB30F

Felt

TRADITIONAL BEATER -Wood-



TTB30W

Wood

SOFT SOUND BEATER



BSQ10S

A quieter bass drum is now as simple as switching the beater on your pedal. Soft Sound Beater provides a significant decrease in volume, but allows you to use your regular bass drum pedal and bass drum head with a natural and accurate feel. It's useful not only for low volume gigs and applications but also practice at low volume.

TOE STOPPER

HP900-81



BEATER BALANCER

BC7



TIGHT LOCK

TLK5



SPRING FOR SPEED COBRA

HP910-7S



SPRING -Regular-

HP900-7R



SPRING -Heavy-

HP900-7H



COBRA COIL

CC900S



The Cobra Coil is a steel spring which assists in the return of the footboard to its original position, so the feel of Speed Cobra becomes even more unreal. Even better, the Cobra Coil can be adjusted to different positions, forward or backward, on the base plate.

DRUM HAMMER

DH7



TWIN PEDAL ATTACHMENT

TPA90

Specially designed attachment to connect Speed Cobra and Iron Cobra 900 series pedals with Speed Cobra and Iron Cobra 900 series Hi-hat stands.



IRON COBRA PEDAL CASES

PC900S/PC900TW

You know what pedals go through night after night. After being stomped on over and over, they get thrown in bags and roadcases where there's more hard rock and roll than the gig itself. That's why precision instruments like our Iron Cobras come with a specially designed protective carrying case. It's amazing no one thought of it before.



PC900S (for Iron Cobra Single Pedal)
PC900TW (for Iron Cobra Twin Pedal)

SPEED COBRA PEDAL CASES



PC910S/PC910TW

You know what pedals go through night after night. After being stomped on over and over, they get thrown in bags and roadcases where there's more hard rock and roll than the gig itself. That's why precision instruments like our Speed Cobras come with a specially designed protective carrying case. It's amazing no one thought of it before.

PC910S (for Speed Cobra Single Pedal)
PC910TW (for Speed Cobra Twin Pedal)

1ST CHAIR ROUND RIDER XL SEAT -Cloth Top-



HTS8BC

You can improve your existing throne with the firm support and comfort of 1st Chair seats (fits pipes from 19.1mm to 25.4mm in diameter).

1ST CHAIR ROUND RIDER XL SEAT



HTS8B

You can improve your existing throne with the firm support and comfort of 1st Chair seats (fits pipes from 19.1mm to 25.4mm in diameter).

1ST CHAIR ROUND RIDER XL SEAT -Red-



HTS8R

You can improve your existing throne with the firm support and comfort of 1st Chair seats (fits pipes from 19.1mm to 25.4mm in diameter).

1ST CHAIR ERGO-RIDER SEAT -Cloth Top-



HTS7BC

You can improve your existing throne with the firm support and comfort of 1st Chair seats (fits pipes from 19.1mm to 25.4mm in diameter).

1ST CHAIR ERGO-RIDER SEAT



HTS7B

You can improve your existing throne with the firm support and comfort of 1st Chair seats (fits pipes from 19.1mm to 25.4mm in diameter).

1ST CHAIR GLIDE RIDER SEAT -Cloth Top-



HTS5BCN

You can improve your existing throne with the firm support and comfort of 1st Chair seats (fits pipes from 19.1mm to 25.4mm in diameter).

1ST CHAIR WIDE RIDER SEAT -Cloth Top-



HTS5BC

You can improve your existing throne with the firm support and comfort of 1st Chair seats (fits pipes from 19.1mm to 25.4mm in diameter).

1ST CHAIR WIDE RIDER SEAT



HTS5B

You can improve your existing throne with the firm support and comfort of 1st Chair seats (fits pipes from 19.1mm to 25.4mm in diameter).

1ST CHAIR ROUND RIDER SEAT -Cloth Top-



HTS4BC

You can improve your existing throne with the firm support and comfort of 1st Chair seats (fits pipes from 19.1mm to 25.4mm in diameter).

1ST CHAIR ROUND RIDER SEAT



HTS4B

You can improve your existing throne with the firm support and comfort of 1st Chair seats (fits pipes from 19.1mm to 25.4mm in diameter).

1ST CHAIR THRONE BASE -HYDRAULIX-



HSB5N

*Seat holder included.

You can improve your existing throne or seat by changing the legs to one of the 1st Chair individual throne bases. The Hydraulix throne base comes with a seat holder with an adjustment lever.

1ST CHAIR THRONE BASE -Quartet-



HSB4N

You can improve your existing throne or seat by changing the legs to one of the 1st Chair individual throne bases. (diameter of upper rods: 22.2mm)

1ST CHAIR THRONE BASE -Trio-



HSB3N

You can improve your existing throne or seat by changing the legs to one of the 1st Chair individual throne bases. (diameter of upper rods: 22.2mm)

1ST CHAIR THRONE BASE -Trio-



HSB3

for Round Rider Series

You can improve your existing throne or seat by changing the legs to one of the 1st Chair individual throne bases. (diameter of upper rods: 22.2mm)

1ST CHAIR BACKREST ATTACHMENT



HTB5B

for any 1st Chair thrones

Sitting on a throne for a long period of time is tough on your back. You could get a throne with a backrest-but they're a pain to transport because they don't fold up. And if you're a player who leans forward, they're no help at all. Unless you get a 1st Chair backrest. The HTB5B can be adjusted up and down AND forward AND it can be detached from the seat when the gig is done. Slick!

TAMA LOGO STICKER -White-



TLS100WH

TLS120WH 60mm x 280mm (2 3/8" x 11 1/32")
TLS100WH 50mm x 230mm (1 31/32" x 9 1/16")
TLS80WH 40mm x 190mm (1 9/16" x 7 1/2")
TLS70WH 35mm x 150mm (1 3/8" x 5 7/8")

TAMA LOGO STICKER -Black-



TLS100BK

TLS120BK 60mm x 280mm (2 3/8" x 11 1/32")
TLS100BK 50mm x 230mm (1 31/32" x 9 1/16")
TLS80BK 40mm x 190mm (1 9/16" x 7 1/2")
TLS70BK 35mm x 150mm (1 3/8" x 5 7/8")

TUNE UP OIL



TOL2

Machine oil for lubricating the moving parts of stands, pedals, and tension bolts. Also protects pedal chains from rust.

SONIC MUTE



TSM01

(2pcs/set)
Removable, reusable & reliable mute patch. Adjustable for optimum precision and control. (Wash lightly to restore adhesion).

MEMORY LOCK



ML11
for 10.5mm diameter L-rod

MEMORY LOCK



ML12
for 10.5-12mm diameter boom arm

MEMORY LOCK



ML191C
for 19.1mm diameter pipe

MEMORY LOCK



ML191N
for 19.1mm diameter pipe

MEMORY LOCK



ML222C
for 22.2mm diameter pipe

MEMORY LOCK



ML222NT
for 22.2mm diameter pipe

MEMORY LOCK



ML254TC
for 25.4mm diameter pipe

MEMORY LOCK



ML254C
for 25.4mm diameter pipe

MEMORY LOCK



ML28C
for 28.6mm diameter pipe

QUICK-SET CYMBAL MATE



QC8
(M8)

QUICK-SET CYMBAL MATE (4pcs/set)



QC8-B4

(M8: 4pcs/pack)

CYMBAL MATE



CM8P

(M8: 2pcs/pack)

RING-TRUE FELT for STAR Hardware



RTF35P

(2pcs/pack)

FELT WASHER



7081P

(2pcs/pack)

REVERSIBLE CYMBAL BOTTOM



RB8P

(M8: 2pcs/pack)

STAR HARDWARE CYMBAL BOTTOM



CB8P

(M8: 2pcs/pack)

CYMBAL PROTECTION SLEEVE



CPS8P

(M8: 2pcs/pack)

HAT STACK



CSH5

- Easily attach a small cymbal to hi-hat rod measuring up to 7mm in diameter
- Compact size and lightweight for easy transport and storage - 25mm (1") diameter x 40mm (1.5") height
- Ability to adjust cymbal sustain

QUICK-SET HI-HAT CLUTCH



QHC7

With just one touch, the Quick-Set Clutch can be attached or removed - simply push the button on the side of the clutch. The clutch also allows the top hi-hat cymbal to float more freely, maximizing the natural resonance of the cymbals.
(Fits 7mm or smaller diameter pull rod)

SWING LOCK CLUTCH



SLC08

This allows the top hi-hat cymbal to float more freely, maximizing the natural resonance of the cymbals.
(Fits 6.3mm diameter pull rod)

SECURITY CLUTCH



CL08

Having your hi-hat clutch come loose is now a thing of the past with TAMA's Security Clutch. When the T-bolt is tightened, bottom lock nut and top section press on the rod for complete security. (Fits 6.3mm diameter pull rod)

HI-HAT TENSION RODS



HH905-3/HH905D3S

Tension Rod w/ Plastic Nut (M6)

HH905-3 (Long / 500mm (19 11/16"))
HH905D3S (Short / 350mm (13 3/4"))

REMOTE HI-HAT STAND CABLE

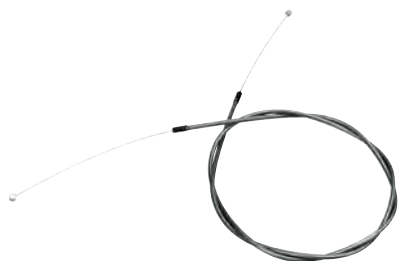

HH905RH2L/HH905RH2S

Exchangeable Cable for HH905RH

HH905RH2L (Long / 2,300mm (90 1/2"))
HH905RH2S (Short / 1,200mm (47 1/4"))

HI-HAT CLUTCH FELT WASHERS



CL08-13P

(2pcs/pack)

QUICK-LOCK TOM BRACKET



MQMP-TCH

(for tom tom/Chrome)
-Quick and easy setup in position
-Enhanced resonance with rubber lining

QUICK-LOCK TOM BRACKET



MQMP-TBN

(for tom tom/Black Nickel)
-Quick and easy setup in position
-Enhanced resonance with rubber lining

QUICK-LOCK TOM BRACKET



MQMP-FCH

(for floor tom/Chrome)
-Quick and easy setup in position
-Enhanced resonance with rubber lining

QUICK-LOCK TOM BRACKET



MQMP-FBN

(for floor tom/Black Nickel)
-Quick and easy setup in position
-Enhanced resonance with rubber lining

SOUND FOCUS PAD -for Cocktail-JAM-



SFP530

Bass Drum Mute for Cocktail-JAM kits

SOUND FOCUS PAD -for Cocktail-JAM Mini-



SFP480

Bass Drum Mute for Cocktail-JAM Mini kits

DRUM STICKS

TAMA drum sticks are molded under strict quality control standards from carefully selected wood materials and are renowned for their consistent high quality.

ORIGINAL SERIES STICK - Japanese Oak-

0213-B

MADE IN JAPAN

Diameter: 13mm (0.510")
Length: 406mm (16")
Tip Style: Ball



ORIGINAL SERIES STICK - Japanese Oak-

0214-B

MADE IN JAPAN

Diameter: 14mm (0.550")
Length: 406mm (16")
Tip Style: Ball



ORIGINAL SERIES STICK - Japanese Oak-

0215-B

MADE IN JAPAN

Diameter: 15mm (0.590")
Length: 406mm (16")
Tip Style: Ball



ORIGINAL SERIES STICK - Japanese Oak-

0216-B

MADE IN JAPAN

Diameter: 16mm (0.630")
Length: 406mm (16")
Tip Style: Ball



ORIGINAL SERIES STICK - Japanese Oak-

0213-P

MADE IN JAPAN

Diameter: 13mm (0.510")
Length: 406mm (16")
Tip Style: Popular



ORIGINAL SERIES STICK - Japanese Oak-

0214-P

MADE IN JAPAN

Diameter: 14mm (0.550")
Length: 406mm (16")
Tip Style: Popular



ORIGINAL SERIES STICK - Japanese Oak-

0215-P

MADE IN JAPAN

Diameter: 15mm (0.590")
Length: 406mm (16")
Tip Style: Popular



ORIGINAL SERIES STICK - Japanese Oak-

0214-S

MADE IN JAPAN

Diameter: 14mm (0.550")
Length: 406mm (16")
Tip Style: Small



ORIGINAL SERIES STICK -Japanese Oak-

0215-S

MADE IN JAPAN

Diameter: 15mm (0.590")
Length: 406mm (16")
Tip Style: Small



ORIGINAL SERIES STICK -American Hickory-

H213-B

MADE IN JAPAN

Diameter: 13mm (0.510")
Length: 406mm (16")
Tip Style: Ball



ORIGINAL SERIES STICK -American Hickory-

H214-B

MADE IN JAPAN

Diameter: 14mm (0.550")
Length: 406mm (16")
Tip Style: Ball



ORIGINAL SERIES STICK -American Hickory-

H215-B

MADE IN JAPAN

Diameter: 15mm (0.590")
Length: 406mm (16")
Tip Style: Ball



ORIGINAL SERIES STICK -American Hickory-

H213-P

MADE IN JAPAN

Diameter: 13mm (0.510")
Length: 406mm (16")
Tip Style: Popular



ORIGINAL SERIES STICK -American Hickory-

H214-P

MADE IN JAPAN

Diameter: 14mm (0.550")
Length: 406mm (16")
Tip Style: Popular



ORIGINAL SERIES STICK -American Hickory-

H215-P

MADE IN JAPAN

Diameter: 15mm (0.590")
Length: 406mm (16")
Tip Style: Popular



TRADITIONAL SERIES STICK -Japanese Oak-

7A

MADE IN JAPAN

Diameter: 13mm (0.510")
Length: 390mm (15 3/8")
Tip Style: 7A



TRADITIONAL SERIES STICK -Japanese Oak-

7AN

MADE IN JAPAN

Diameter: 13mm (0.510")
Length: 390mm (15 3/8")
Tip Style: 7A (Nylon)



TRADITIONAL SERIES STICK -Japanese Oak-

5A

MADE IN JAPAN

Diameter: 14mm (0.550")
Length: 406mm (16")
Tip Style: 5A



TRADITIONAL SERIES STICK -Japanese Oak-

5AN

MADE IN JAPAN

Diameter: 14mm (0.550")
Length: 406mm (16")
Tip Style: 5A (Nylon)



TRADITIONAL SERIES STICK -Japanese Oak-

8A

MADE IN JAPAN

Diameter: 14mm (0.550")
Length: 406mm (16")
Tip Style: 8A



TRADITIONAL SERIES STICK -Japanese Oak-

5B

MADE IN JAPAN

Diameter: 15mm (0.590")
Length: 406mm (16")
Tip Style: 5B



TRADITIONAL SERIES STICK -Japanese Oak-

5BN

MADE IN JAPAN

Diameter: 15mm (0.590")
Length: 406mm (16")
Tip Style: 5B (Nylon)



TRADITIONAL SERIES STICK -American Hickory-

H7A

MADE IN JAPAN

Diameter: 13mm (0.510")
Length: 390mm (15 3/8")
Tip Style: 7A



TRADITIONAL SERIES STICK -American Hickory-

H5A

MADE IN JAPAN

Diameter: 14mm (0.550")
Length: 406mm (16")
Tip Style: 5A



TRADITIONAL SERIES STICK -American Hickory-

H8A

MADE IN JAPAN

Diameter: 14mm (0.550")
Length: 406mm (16")
Tip Style: 8A



TRADITIONAL SERIES STICK -American Hickory-

H5B

MADE IN JAPAN

Diameter: 15mm (0.590")
Length: 406mm (16")
Tip Style: 5B



OAK LAB SERIES -Smash-

OL-SM

MADE IN JAPAN

Weight and balance for huge power.

Diameter: 15mm (0.590")
Length: 419mm (16 1/2")
Tip Style: Acorn



OAK LAB SERIES -Resonator-

OL-RE

MADE IN JAPAN

Heavy for rich tones. Quick rebound.

Diameter: 15.25mm (0.600")
Length: 410mm (16 5/32")
Tip Style: Arrow



OAK LAB SERIES -Fast Blast-

OL-FA

[MADE IN JAPAN](#)

(Natural / Uncoated)
Modified 5A for more speed. Large tip and Oak enhances volume.

Diameter: 14mm (0.550")
Length: 406mm (16")
Tip Style: Large Ball



OAK LAB SERIES -Swingin'-

OL-SW

[MADE IN JAPAN](#)

Oak provides a bright cymbal tone and enhanced cross stick sound.

Diameter: 12.75mm (0.500")
Length: 403mm (15 7/8")
Tip Style: Oval



OAK LAB SERIES -Full Balance-

OL-FU

[MADE IN JAPAN](#)

Weighted for accuracy and control.

Diameter: 14.5mm (0.570")
Length: 406mm (16")
Tip Style: True Round



CANVAS SERIES -Japanese Oak-

5ACV-DG

[MADE IN JAPAN](#)

(Green, Silver Printing)

Diameter: 14mm (0.550")
Length: 406mm (16")
Tip Style: 5A



CANVAS SERIES -Japanese Oak-

5ACV-LB

[MADE IN JAPAN](#)

(Light Blue, Blue Printing)

Diameter: 14mm (0.550")
Length: 406mm (16")
Tip Style: 5A



CANVAS SERIES -Japanese Oak-

5ACV-WH

[MADE IN JAPAN](#)

(White, Blue Printing)

Diameter: 14mm (0.550")
Length: 406mm (16")
Tip Style: 5A



STAGEMAX -Japanese Oak-

5A-MS

[MADE IN JAPAN](#)

(Natural / Uncoated)

Diameter: 14mm (0.550")
Length: 406mm (16")
Tip Style: 5A



STAGEMAX -Japanese Oak-

5B-MS

[MADE IN JAPAN](#)

(Natural / Uncoated)

Diameter: 15mm (0.590")
Length: 406mm (16")
Tip Style: 5B



STAGEMAX -American Hickory-

H5A-MS

[MADE IN JAPAN](#)

(Natural / Uncoated)

Diameter: 14mm (0.550")
Length: 406mm (16")
Tip Style: 5A



STAGEMAX -American Hickory-

H5B-MS

[MADE IN JAPAN](#)

(Natural / Uncoated)

Diameter: 15mm (0.590")
Length: 406mm (16")
Tip Style: 5B



REDZONE -Japanese Oak-

5ARZ

(Silver Logo)

[MADE IN JAPAN](#)

Diameter: 14mm (0.550")
Length: 419mm (16 1/2")
Tip Style: 5A (Nylon)



REDZONE -Japanese Oak-

5BRZ

(Silver Logo)

[MADE IN JAPAN](#)

Diameter: 15mm (0.590")
Length: 419mm (16 1/2")
Tip Style: 5B (Nylon)



REDZONE -Japanese Oak-

5ARZK

(Silver Logo)

[MADE IN JAPAN](#)

Diameter: 14mm (0.550")
Length: 419mm (16 1/2")
Tip Style: Knocker



REDZONE -American Hickory-

H5ARZ

(Gold Logo)

[MADE IN JAPAN](#)

Diameter: 14mm (0.550")
Length: 419mm (16 1/2")
Tip Style: 5A (Nylon)



REDZONE -American Hickory-

H5BRZ

(Gold Logo)

[MADE IN JAPAN](#)

Diameter: 15mm (0.590")
Length: 419mm (16 1/2")
Tip Style: 5B (Nylon)



REDZONE -American Hickory-

H5ARZK

(Gold Logo)

[MADE IN JAPAN](#)

Diameter: 14mm (0.550")
Length: 406mm (16")
Tip Style: Knocker



RHYTHMIC FIRE -Japanese Oak-

7A-F

(Natural)

[MADE IN JAPAN](#)

Diameter: 13mm (0.510")
Length: 390mm (15 3/8")
Tip Style: 7A



RHYTHMIC FIRE -Japanese Oak-

5A-F

(Natural)

[MADE IN JAPAN](#)

Diameter: 14mm (0.550")
Length: 406mm (16")
Tip Style: 5A



RHYTHMIC FIRE -Japanese Oak-

5B-F

(Natural)

[MADE IN JAPAN](#)

Diameter: 15mm (0.590")
Length: 406mm (16")
Tip Style: 5B



RHYTHMIC FIRE -Japanese Oak-

7A-F-BS

(Black, Silver Pattern)

[MADE IN JAPAN](#)

Diameter: 13mm (0.510")
Length: 390mm (15 3/8")
Tip Style: 7A



RHYTHMIC FIRE -Japanese Oak-

5A-F-BS

[MADE IN JAPAN](#)

(Black, Silver Pattern)

Diameter: 14mm (0.550")
Length: 406mm (16")
Tip Style: 5A



RHYTHMIC FIRE -Japanese Oak-

5B-F-BS

[MADE IN JAPAN](#)

(Black, Silver Pattern)

Diameter: 15mm (0.590")
Length: 406mm (16")
Tip Style: 5B



RHYTHMIC FIRE -Japanese Oak-

7A-F-BR

[MADE IN JAPAN](#)

(Black, Red Pattern)

Diameter: 13mm (0.510")
Length: 390mm (15 3/8")
Tip Style: 7A



RHYTHMIC FIRE -Japanese Oak-

5A-F-BR

[MADE IN JAPAN](#)

(Black, Red Pattern)

Diameter: 14mm (0.550")
Length: 406mm (16")
Tip Style: 5A



RHYTHMIC FIRE -Japanese Oak-

5B-F-BR

[MADE IN JAPAN](#)

(Black, Red Pattern)

Diameter: 15mm (0.590")
Length: 406mm (16")
Tip Style: 5B



STICKS OF DOOM -Japanese Oak-

7A-S

[MADE IN JAPAN](#)

(Natural)

Diameter: 13mm (0.510")
Length: 390mm (15 3/8")
Tip Style: 7A



STICKS OF DOOM -Japanese Oak-

5A-S

[MADE IN JAPAN](#)

(Natural)

Diameter: 14mm (0.550")
Length: 406mm (16")
Tip Style: 5A



STICKS OF DOOM -Japanese Oak-

5B-S

[MADE IN JAPAN](#)

(Natural)

Diameter: 15mm (0.590")
Length: 406mm (16")
Tip Style: 5B



STICKS OF DOOM -Japanese Oak-

7A-S-BS

[MADE IN JAPAN](#)

(Black, Silver Pattern)

Diameter: 13mm (0.510")
Length: 390mm (15 3/8")
Tip Style: 7A



STICKS OF DOOM -Japanese Oak-

5A-S-BS

[MADE IN JAPAN](#)

(Black, Silver Pattern)

Diameter: 14mm (0.550")
Length: 406mm (16")
Tip Style: 5A



STICKS OF DOOM -Japanese Oak-

5B-S-BS

(Black, Silver Pattern)

Diameter: 15mm (0.590")
Length: 406mm (16")
Tip Style: 5B

MADE IN JAPAN



DIRK VERBEUREN MODEL -Japanese Oak-

O-DVM

Dirk Verbeuren (MEGADETH)

Diameter: 16mm (0.630")
Length: 406mm (16")

MADE IN JAPAN



MARIO DUPLANTIER MODEL -American Hickory-

H-MD

Mario Duplantier (Gojira)

Diameter: 16.5mm (0.649")
Length: 432mm (17")

MADE IN JAPAN



JEREMY COLSON MODEL -American Hickory-

H-JCS

Jeremy Colson (Steve Vai)

Diameter: 16.5mm (0.649")
Length: 422mm (16.6")

MADE IN JAPAN



YOSHIKI MODEL -American Hickory-

H-YKB

YOSHIKI (X-JAPAN / VIOLET UK)

Diameter: 14.25mm (0.561")
Length: 398mm (15 5/8")

MADE IN JAPAN



YOSHIKI MODEL -American Hickory-

H-YKM

YOSHIKI (X-JAPAN / VIOLET UK)

H-YKM features special matte coating which prevents slipping sticks off by sweat.

Diameter: 14.25mm (0.561")
Length: 398mm (15 5/8")

MADE IN JAPAN



RHYTHM MATE SERIES STICK -Hickory-

HRM7A

Diameter: 13.5mm (0.530")
Length: 394mm (15 1/2")



RHYTHM MATE SERIES STICK -Hickory-

HRM2B

Diameter: 16mm (0.629")
Length: 406mm (16")



RHYTHM MATE SERIES STICK -Maple-

MRM5A

Diameter: 14mm (0.550")
Length: 406mm (16")

MRM7A

Diameter: 13.5mm (0.530")
Length: 394mm (15 1/2")



RHYTHM MATE SERIES STICK -Maple-

MRM5B

Diameter: 15mm (0.590")
Length: 406mm (16")

MRM2B

Diameter: 16mm (0.629")
Length: 406mm (16")





TAMA Drums distributed by

Roland Meinl Musikinstrumente GmbH & Co. KG
Musik-Meinel-Str. 1 · 91468 Gutenstetten · Germany
Tel. +49 (0) 9161 7880 · Fax. +49 (0) 9161 788 100
info@meinldistribution.eu



TAMA[®]

 Tama Drums  Tama Official  officialtamadrums  @TAMAofficial

www.tama.com

Actual product colors may not exactly be the same as the one shown on the catalog photos due to lighting and photo resolution. All specifications are subject to change without notice.

©2019 TAMA DRUMS All rights reserved. (E)