

# S.L.P. SOUND LAB PROJECT DRUM KITS

## DISTINCTIVE CHARACTERISTICS WITH UNIQUE SPECS

These new S.L.P. series drum kits are based on the concept the S.L.P. snare drum series, which have become very popular worldwide for their wide range of features and sound characteristics. Like the snares, each kit model has its own original sound and distinct features such as hoops, lugs and tom brackets, that were carefully selected to achieve the full potential of its shell material. We even chose particular sizes and configurations for each kit to emphasize its individual character. Each kit really shines in particular musical styles and can help to enhance the quality of a band's sound.

The lineup includes 3 ongoing production models – Studio Maple, Fat Spruce, and Dynamic Kapur. The Studio Maple and Fat Spruce are already very popular S.L.P. snare drums, and the kits adopt the features and specs of their respective snares. The Dynamic Kapur features Kapur material, which we heavily researched and liked for its distinctive sound with rich mids and great projection.

In addition, we will also offer a limited edition kit, the S.L.P. G Bubinga – based on the snare of the same name – which features extra thick Bubinga shells.



**STUDIO MAPLE**

**FAT SPRUCE**

**DYNAMIC KAPUR**

**G-BUBINGA**

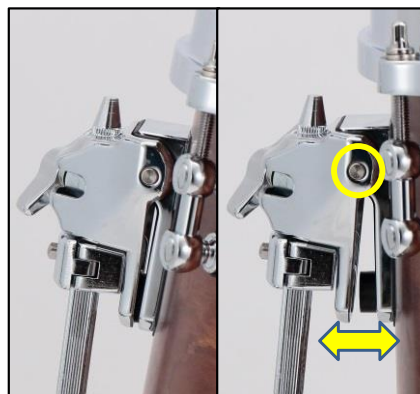
### NEW FEATURE



#### Direct Flexi-Mount

This Direct Flexi-Mount utilizes a two-piece structure – a plate that is mounted to the shell, and another piece that receives the L-rod of a tom holder/stand. These two parts are hinged together using a steel shaft, allowing some slight horizontal play when striking the drum. This controls the vibration of the shell while still allowing it to resonate more freely than traditional direct-to-shell mounts. This in turn provides smooth decay for a clear sound that draws out the intrinsic characteristics of the shell material.

(For Studio Maple, Fat Spruce & G-Bubinga LTD)

# S.L.P. SOUND LAB PROJECT DRUM KITS

## DISTINCTIVE CHARACTERISTICS WITH UNIQUE SPECS

These new S.L.P. series drum kits are based on the concept the S.L.P. snare drum series, which have become very popular worldwide for their wide range of features and sound characteristics. Like the snares, each kit model has its own original sound and distinct features such as hoops, lugs and tom brackets, that were carefully selected to achieve the full potential of its shell material. We even chose particular sizes and configurations for each kit to emphasize its individual character. Each kit really shines in particular musical styles and can help to enhance the quality of a band's sound.

The lineup includes 3 ongoing production models – Studio Maple, Fat Spruce, and Dynamic Kapur. The Studio Maple and Fat Spruce are already very popular S.L.P. snare drums, and the kits adopt the features and specs of their respective snares. The Dynamic Kapur features Kapur material, which we heavily researched and liked for its distinctive sound with rich mids and great projection.

**STUDIO MAPLE**

**FAT SPRUCE**

**DYNAMIC KAPUR**

### NEW FEATURE

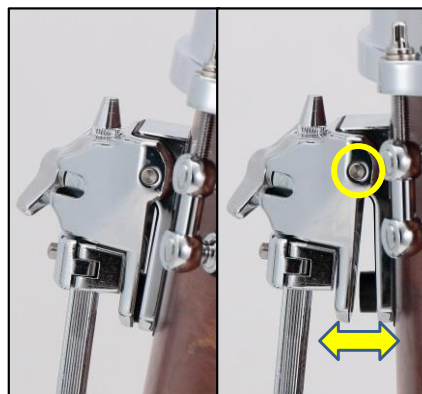

#### Direct Flexi-Mount

This Direct Flexi-Mount utilizes a two-piece structure – a plate that is mounted to the shell, and another piece that receives the L-rod of a tom holder/stand. These two parts are hinged together using a steel shaft, allowing some slight horizontal play when striking the drum. This controls the vibration of the shell while still allowing it to resonate more freely than traditional direct-to-shell mounts. This in turn provides smooth decay for a clear sound that draws out the intrinsic characteristics of the shell material.  
(For Studio Maple & Fat Spruce)



# S.L.P. SOUND LAB PROJECT DRUM KITS

## STUDIO MAPLE

The Studio Maple kit is very original model in both sound and appearance, with Sound Focus Rings on the inside of the shells and 100% Maple Wood Hoops. It has a focused, warm, woody tone with clear attack, and a relatively short sustain with beautiful decay. While great for live performance, this model really excels in the studio, especially when seeking a warm sound with controlled resonance.



LMP52RTLS-GSE

### SPECIFICATIONS

- All Maple Shell w/Sound Focus Ring (TT/FT) 6ply, 5mm / (BD) 8ply, 6mm



- Maple Wood Hoop



- Direct Flexi-Mount



- Evans G1 Coated Head
- Starclassic Lug

### FEATURES

- Extra warm with rich tone and focused attack
- 100% maple wood hoops, coated with urethane for more durability
- Suggested musical styles: R&B, Country, Classic Rock & Pop

### PRODUCT INFO.

Model #	Description	Finish	EAN	Availability	PRICE
LMP52RTLS	Drum Shell Kit – 16"x22" BD, 7"x10" & 8"x12" TT, 14"x14" & 16"x16" FT, MTH1000 Double Tom Holder	Gloss Sienna (GSE)	4549763061157	End of April	60.920,00 Kc 2.299,00 €
LMP42RTLS	Drum Shell Kit – 16"x22" BD, 7"x10" & 8"x12" TT, 16"x16" FT, MTH1000 Double Tom Holder		4549763061164	On Stock	50.320,00 Kc 1.899,00 €

# S.L.P. SOUND LAB PROJECT DRUM KITS

## FAT SPRUCE

The Fat Spruce kit features luxurious 100% Spruce shells, which is rarely used as a material on complete drum sets. Its unique sound is fat and resonant with solid mids and a natural pure tone. Furthermore, by utilizing die-cast hoops, it provides a very clear, focused attack.

It also has a very wide tuning range, making it suitable for a number of music styles. The drums sound great tuned up high for jazz, but also perform well at low to medium tension, optimal for R&B, Blues, Indie Rock and Ballads.



LSP30CS-TWS

### FEATURES

- Fat natural tone with enhanced mid-low frequencies
- Beautiful wood grain finish from hand selected spruce wood
- Suggested musical styles: R&B, Ballad, Indie Rock & Jazz

### PRODUCT INFO.

Model #	Description	Finish	EAN	Availability	PRICE
LSP30CS	Drum Shell Kit – 14"x20" BD, 8"x12" TT, 14"x14" FT, MTH900BM Single Tom Holder	Satin Wild Spruce (TWS)	4549763061140	End of April	34.420,00 Kc 1.299,00 €

### SPECIFICATIONS

#### - All Spruce Shell

(TT/FT) 6ply, 5mm / (BD) 8ply, 7mm



#### - Die-Cast Hoop



#### - Direct Flexi-Mount



#### - Evans G1 Coated Head

#### - Brass Tube Lug

#### - 3pc 20" BD Configuration

# S.L.P. SOUND LAB PROJECT DRUM KITS

## DYNAMIC KAPUR

This model features Kapur material, which has caught many drummers' attention for its open lively sound with great projection. We paired it with our Sound Arc Hoops for plenty of attack and moderately controlled overtones of the Kapur shells. It offers warm resonance and a very natural, comfortable feel. Because of its articulate sound and enhanced attack, it works very well for funk, fusion and gospel. The high volume potential also lends itself perfectly to rock music.



LKP52HTS-GKP

### FEATURES

- Open lively sound with great projection
- Sound Arc Hoops for attack, volume, and controlled overtones
- Suggested musical styles: Rock, Funk, Fusion & Gospel

### SPECIFICATIONS

- All Kapur Shell  
(TT/FT) 6ply, 5mm / (BD) 7ply, 6mm



- Sound Arc Hoop



- Star-Mount



- Evans G1 Coated Head
- Brass Tube Lug
- Hyper-Drive Toms

### PRODUCT INFO.

Model #	Description	Finish	EAN	Availability	PRICE
LKP52HTS	Drum Shell Kit – 16"x22" BD, 6.5"x10" & 7"x12" TT, 12"x14" & 14"x16" FT, MTH905N Double Tom Holder	Gloss Black Kapur Burst (GKP)	4549763061188	On Stock	47.670,00 Kc 1.799,00 €
LKP42HTS	Drum Shell Kit – 16"x22" BD, 6.5"x10" & 7"x12" TT, 14"x16" FT, MTH905N Double Tom Holder		4549763061195	On Stock	39.720,00 Kc 1.499,00 €



# S.L.P. SOUND LAB PROJECT DRUM KITS

## G-BUBINGA

The G-Bubinga kit is based on the S.L.P. snares' best selling model of the same name. While each drum contains 12 plies, the thickness of the center material is slightly adjusted based on the harmonic overtone characteristics of each size. While the thick Bubinga shell is particularly well suited for the super deep bass drum sound, we were able to achieve excellent tonal balance across the whole drum set. In addition, the gorgeous wood grain of the Quilted Bubinga outer ply, combined with Black Nickel shell hardware, make for a stunning appearance that is sure to catch attention.



LGB42BSQ-GNQ

### FEATURES

- Incredibly powerful solid sound with extra low-end
- Stunning look from Quilted Bubinga outer ply and Black Nickel hardware
- Suggested musical styles: R&B, Hard Rock & Heavy Metal

### PRODUCT INFO.

Model #	Description	Finish	EAN	Availability	PRICE
LGB62BSQ	Drum Shell Kit – 18"x22" BD, 7"x8", 8"x10" & 9"x12" TT, 14"x14" & 16"x16" FT, MTH1000BN Double Tom Holder	Gloss Natural Quilted Bubinga (GNQ)	4549763061218	On Stock	105.970,00 Kc 3.999,00 €
LGB42BSQ	Drum Shell Kit – 18"x22" BD, 8"x10" & 9"x12" TT, 16"x16" FT, MTH1000BN Double Tom Holder				79.470,00 Kc 2.999,00 €

### SPECIFICATIONS

- **G-Bubinga Shell w/Quilted Bubinga Outer Ply**  
11ply Bubinga + 1 outer ply Quilted Bubinga: (TT/FT) 8mm / (BD) 9mm



- **Steel Mighty Hoop**



- **Direct Flexi-Mount**



- **Evans G2 Clear Head**
- **Starclassic Lug**

# SUPERSTAR HYPER-DRIVE DUO KIT

## FEATURING 10"X14" DUO SNARE

This new Superstar Hyper-Drive Duo is a unique and exciting series which will bring new value to the current drumming world. Similar to the groundbreaking work we did with the Superstar Hyper-Drive's extra shallow toms in 2008 - drawing inspiration drawn from recent performances of cutting-edge drummers - we have once again created distinct drum setups which are poised to inspire drummers. Opening the door to new approaches to drumming beyond the standard. The key component of this series is the 10" x 14" snare drum, which we call the "Duo Snare". This drum is unique not only because of its uncommon 10" depth, but also because it is equipped with floor tom legs and brackets. You can tune this drum low and place it where the first floor tom would traditionally go. As such, the snare can function as a low/deep snare with the snare wires engaged, or as a 14" floor tom with the snares off. This can lead to many unique phrasing opportunities.

Once you experience playing on this new kit your eyes and ears will be opened to the infinite range of possibilities, plus it's a lot of fun. Just try it.



ML52HZBN2-BSV

### FEATURES

- 10"x14" Duo Snare which inspires many unique phrasing is included
- Three special vertical finishes only for Superstar Hyper-Drive Duo
- 100% Maple Shell's powerful character and rich resonance

 10"x14" Duo Snare  
w/Floor Tom Legs and Brackets

# SUPERSTAR HYPER-DRIVE DUO KIT

## FEATURING 10"X14" DUO SNARE

### CONFIGURATIONS & FINISHES

ML40HZBN2 - 4pc Shell Kit



Satin Blue Vertical Stripe (SBV)

ML52HZBN2 – 5pc Shell Kit



Satin Silver Vertical Stripe (SSV)



Flat Black Vertical Stripe (FBV)

### PRODUCT INFO.

Model #	Description	Finish	Availability	PRICE
ML52HZBN2	Drum Shell Kit – 16"x22" BD, 6.5"x10" & 7"x12" TT, 14"x16" FT, 10"x14" Duo Snare, MC69 Single Tom Attachment x 2	Satin Blue Vertical Stripe (SBV) Satin Silver Vertical Stripe (SSV)	On Stock	37.070,00 Kc 1.399,00 €
ML40HZBN2	Drum Shell Kit – 16"x20" BD, 7"x12" TT, 14"x16" FT, 10"x14" Duo Snare, MC69 Single Tom Attachment	Flat Black Vertical Stripe (FBV)	On Stock	31.770,00 Kc 1.199,00 €



# SUPERSTAR CLASSIC

## 100% MAPLE SHELL

For more than forty years, the Superstar name has stood for groundbreaking design, superior build quality, sterling tone, and clear projection. Superstar Classic once again upholds tradition by raising the bar for discerning drummers—and remarkably—does it while also lowering the price. Drawing on Superstar of the past, its classic TAMA T-shape badge and streamlined low-mass single lugs point to the simpler state of art of the 70's, while the ingenious Star-Mount system and new thinner gauge 100% maple shells eclipse anything in its class.

### CONFIGURATIONS

#### CL52KRS

(22"BD 5pc Shell kit)

- 7" x 10" Tom Tom
- 8" x 12" Tom Tom
- 14" x 16" Floor Tom
- 16" x 22" Bass Drum
- 6.5" x 14" Snare Drum
- MTH600 Double Tom Holder

#### CL52KR

(22"BD 5pc Shell kit & MM5WN)

#### CL50RS

(20"BD 5pc Shell kit)

- 7" x 10" Tom Tom
- 8" x 12" Tom Tom
- 14" x 14" Floor Tom
- 16" x 20" Bass Drum
- 5" x 14" Snare Drum
- MTH600 Double Tom Holder

#### CL50R

(20"BD 5pc Shell kit & MM5WN)

\*CL50R(S) is available in May



CL52KR-BAB

### AVAILABLE FINISHES



Blue Lacquer Burst (BAB)



Coffee Fade (CFF)



Tangerine Lacquer Burst (TLB)

## FEATURES

### 100% Maple Shells

Tom Tom, Floor Tom & Snare Drum : 6ply, 5mm  
 Bass Drum : 8ply, 7mm

Our highest priority in producing the Superstar series of drums was sound. The full, powerful character and rich resonance of the Superstar drums were achieved by utilizing carefully selected maple shells and focusing intently on shell molding and the bearing edge shape.

### Star-Mount System

The Star-Mount System was developed to increase the resonance of drums. This mounting system provides support at four points on the batter side hoop of a drum. The bracket eye-bolts slide to the left and right, so it's possible to prevent the eye-bolts from touching each other even when setting up two toms close to each other.



### Stage Master 40 Series HW Pack

(for CL52KR, CL50R)



MM5WN

## SPECIFICATIONS

- 100% Maple Shells
  - Star-Mount System
  - Triple Flanged Hoop
  - Low-Mass Lug
  - Power Craft II Drumheads
  - Claw Hooks w/ Rubber Spacers
  - Stage Master 40 Series Hardware\*
  - Iron Cobra 200 Drum Pedal\*
- \* For CL52KR, CL50R

## PRODUCT INFO.

Model #	Description	Finish	Availability	PRICE
<b>CL52KRS</b>	Drum Shell Kit - 16"x22" BD, 7"x10" & 8"x12" TT, 14"x16" FT, 6.5"x14" SD, MTH600 Double Tom Holder		End of April	21.170,00 Kc 799,00 €
<b>CL52KR</b>	Drum Shell Kit & HW pack - 16"x22" BD, 7"x10" & 8"x12" TT, 14"x16" FT, 6.5"x14" SD, MTH600 Double Tom Holder, MM5WN HW Pack (HP200P, HH45W, HC43BW x2, HS40W)	Blue Lacquer Burst (BAB) Coffee Fade (CFF)	End of April	26.470,00 Kc 999,00 €
<b>CL50RS</b>	Drum Shell Kit - 16"x22" BD, 7"x10" & 8"x12" TT, 14"x14" FT, 5"x14" SD, MTH600 Double Tom Holder	Tangerine Lacquer Burst (TLB)	Middle of June	21.170,00 Kc 799,00 €
<b>CL50R</b>	Drum Shell Kit & HW pack - 16"x22" BD, 7"x10" & 8"x12" TT, 14"x14" FT, 5"x14" SD, MTH600 Double Tom Holder, MM5WN HW Pack (HP200P, HH45W, HC43BW x2, HS40W)		Middle of June	26.470,00 Kc 999,00 €

# CLUB-JAM KIT

## COMPACT VINTAGE KIT

We are proud to offer a new compact kit – the "Club-JAM" Kit. This kit adopts some ideas from vintage kits, such as a cymbal holder mounted directly on the bass drum shell and curved bass drum spurs, further setting it apart from the typical compact kit.

Focused yet deep sound from Mersawa / Poplar hybrid shell is just right for small and intimate gigs. Its compact size and configuration make it ideal for working drummers, and it fits comfortably on just about any stage.

It is available as a 4pc complete kit with hardware, or as 4pc shell pack.



LJK48H4-AQB



Bass Drum Mounted Cymbal Holder



DSS48LJ Bag Set Sold Separately

### FEATURES

- 6ply 7mm Mersawa / Poplar hybrid shell
- Compact sizes for easy transport
- Bass drum mounted cymbal holder



Satin Blonde (SBO)



Charcoal Mist (CCM)

### PRODUCT INFO.

Model #	Description	Finish	Availability	PRICE
LJL48S	Drum Shell Kit – 12"x18" BD, 7"x10" TT, 7"x14" FT, 5"x13" SD, cymbal holder	Satin Blonde (SBO)	On Stock	13.220,00 Kc 499,00 €
LJK48H4	Complete Drum Kit incl. HW – 12"x18" BD, 7"x10" TT, 7"x14" FT, 5"x13" SD, hi-hat stand, drum pedal, snare stand, cymbal holder, drum throne	Aqua Blue (AQB) Charcoal Mist (CCM)	Middle of February	14.550,00 Kc 549,00 €
LJK48S	Drum Shell Kit – 12"x18" BD, 7"x10" TT, 7"x14" FT, 5"x13" SD, cymbal holder		Middle of February	10.570,00 Kc 399,00 €



# S.L.P. SOUND LAB PROJECT

## DYNAMIC KAPUR

This model features Kapur material, which has caught many drummers' attention for its open lively sound with great projection. We paired this 6.5" x 14" shell with our Sound Arc Hoops for plenty of attack and moderately controlled overtones. It offers warm resonance and a very natural, comfortable feel. Because of its articulate and slightly dry sound with enhanced attack, it works very well for funk, fusion and gospel. The high volume potential also lends itself perfectly to rock music.



LKP1465-KPB

### FEATURES

- Articulate and slightly dry sound with great projection
- Sound Arc Hoops for attach, volume, and controlled overtones
- Suggested musical styles: Rock, Funk, Fusion & Gospel

### **PRODUCT INFO.**

<b>Model #</b>	LKP1465
<b>Size</b>	6.5" x 14"
<b>Shell</b>	5mm, 6ply Kapur
<b>Lug</b>	MTL60 Brass Tube Lug
<b>Hoop</b>	Sound Arc Hoop (8 Hole)
<b>Head</b>	EVANS G1 Coated / Snare Side
<b>Strainer/Butt</b>	"Linear-Drive" Strainer & Butt (MLS50A / MLS50B)
<b>Snare Wire</b>	MS20SN14S
<b>Finish</b>	Black Kapur Burst (KPB)
<b>EAN Code</b>	4549763061805
<b>Availability</b>	On Stock
<b>PRICE</b>	7.920,00 Kc / 299,00 €

# S.L.P. SOUND LAB PROJECT

## DUO BIRCH

New ideas are often conceived by combining a few existing ideas into something fresh and exciting. This Duo Birch was born just that way. It is a very unique 10" x 14" Birch drum equipped with snare wires on the bottom head and 3 floor tom legs for mounting. The result? It can be used either as a floor tom or snare drum, simply by switching the wires on or off. In either case, the sound is still pretty unique due to the size and specs of the drum – allowing drummers to explore ideas and create new patterns and fills they might never have considered with traditional setups.



LBH1410L-TPM

### FEATURES

- One-of-a-kind drum combining floor tom and snare drum specs
- Floor tom legs allow for easy & flexible positioning
- Adjustable snare strainer



EVANS Power Center Reverse Dot equipped

### PRODUCT INFO.

<b>Model #</b>	LBH1410L
<b>Size</b>	10" x 14"
<b>Shell</b>	7mm, 7ply Birch
<b>Lug</b>	MSL-SCT Lug
<b>Hoop</b>	Sound Arc Hoop (8 Hole)
<b>Head</b>	EVANS Power Center Reverse Dot / Snare Side
<b>Strainer/Butt</b>	MCS70A / MCS70B
<b>Snare Wire</b>	MS20R14S
<b>Finish</b>	Transparent Mocha (TPM)
<b>EAN Code</b>	4549763062208
<b>Note</b>	MTB25E Brackets Equipped, MFLSL3P Legs Included
<b>Availability</b>	End of June
<b>PRICE</b>	7.920,00 Kc / 299,00 €

# NEW FINISHES

## STAR MAPLE



Ocean Blue Curly Maple (ROLC)





# NEW FINISHES

## STAR MAPLE



Raspberry Curly Maple (RRCM)



# NEW FINISHES

## STAR WALNUT



## Indigo Japanese Sen Burst (AIJB)





# NEW FINISHES

## STARCLASSIC



Ruby Pacific Walnut Burst (LRWB)  
Starclassic Maple – Exotic Finish



Flat Deep Green Metallic (FDG)  
Starclassic Bubinga / Maple



Lacquered White Oyster (LWO)  
Starclassic Performer B/B – Lacquer

## SILVERSTAR



Dark Cherry Wine (DCW)  
Lacquer Finish



Vintage White Sparkle (VWS)  
Unicolor Wrap Finish



Dark Red Sparkle (DRP)  
Unicolor Wrap Finish  
\* already available

## RHYTHM MATE



Hairline Blue (HLB)  
Unicolor Wrap Finish



# THE CLASSIC PEDAL

## VINTAGE INSPIRED PEDAL WITH NATURAL FEEL & RESPONSE

The Classic Pedal takes a sophisticated path to simplicity, to stimulate joy and provide comfort for its player.

Due to their simple, user-friendly nature and natural feel, vintage pedals have remained popular in modern times, when technology and innovation abound. While incorporating great practical features from vintage models, we designed this pedal with TAMA's up-to-date engineering and years of product research and development.

The streamlined footboard was carefully designed, with great attention to detail, so that it is easy to use in any playing style. Inspired by some vintage pedals, we developed a height adjustment mechanism that precisely strikes the center of the head on a range of bass drum sizes. And above all, its weight balance achieves a very natural feel and response, while still delivering power and nuance. This comfortable feeling allows that player to forget about the pedal itself and instead focus on playing music, naturally inspiring joy and creativity.



### FEATURES



#### Center Strike Height Adjust

By simply loosening the square head bolt of the side pillar, you can change the height of the beater shaft. This makes it possible to have the beater strike the center of the bass drum without using a bass drum lifter or adjusting the length of the beater.



#### Easy Access Spring Adjustment

This unique Easy Adjust Spring Post allows you to adjust the spring tension while still sitting on the drum throne because of its top mounted construction. This means you can adjust the tension while actually checking the resulting feel simultaneously.

# THE CLASSIC PEDAL

## VINTAGE INSPIRED PEDAL WITH NATURAL FEEL & RESPONSE

### FEATURES



#### The Classic Beater

This traditional style round beater has a slightly tapered shape. It allows you to hit the bass drum evenly, and provides a warm sound with clear articulation.



#### Smooth Surface Footboard

The newly designed classic style footboard features lightweight construction and smooth surface, making it a great choice for any drumming style.



Beater Angle Adjustment

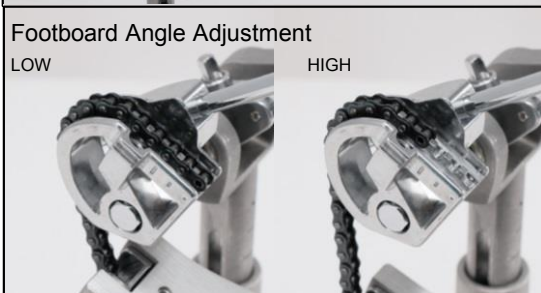

Footboard Angle Adjustment

LOW

HIGH

#### Individual Adjustment of Beater & Footboard Angle

Using a drum key, you can adjust the beater angle as desired. Also, by changing the chain position on the sprocket, you can adjust the footboard angle independently of the beater angle.



#### Easy-Tight Hoop Clamp

We set the screw to tighten the hoop clamp on the outside of the pedal frame, making it quick and easy to set and remove.



#### Compact Folding Design

This pedal can be folded compactly to store it in a pedal bag. By tilting the spring post toward you, it becomes a compact right-angle triangle.

### PRODUCT INFO.

Model #	Description	EAN Code	Availability	PRICE
HP50	Drum Pedal	4549763043627	Middle of April	2.620,00 Kc 99,00 €

# THE CLASSIC STAND SERIES

## FEATURING COMPACT & LIGHTWEIGHT DESIGN

Inspired by the vintage cymbal stands of the 1960s, we are proud to announce our new extremely lightweight and compact Classic Stands. These stands are not merely a rehash of old designs, but a beautiful blend of vintage style with the strength, adjustability, and reliability of modern construction.

### FEATURES

#### Compact & Lightweight Design

The uniquely compact and lightweight design is perfect for when you need to travel lightly.

		Size when folded	Weight
HH55F	Hi-Hat Stand	500mm (Upper Section) 598mm (Base Section)	2.3kg
HS50S	Snare Stand	600mm	1.7kg
HTS58F	Tom Stand	598mm (Upper Section) 407mm (Base Section)	1.8kg

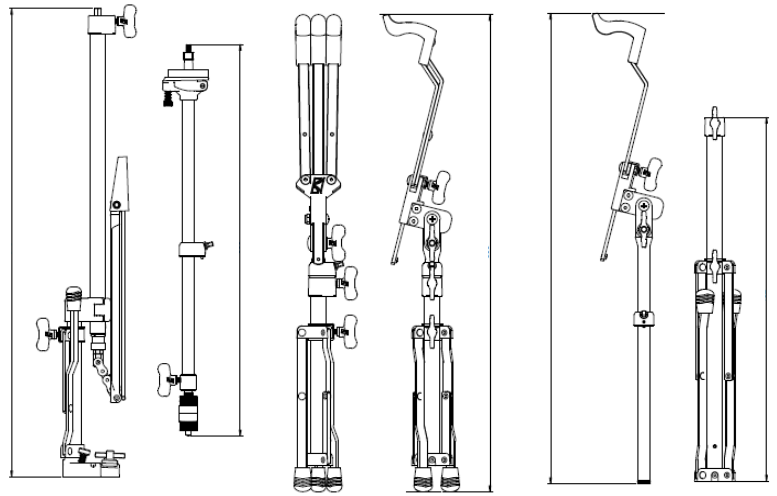

HH55F

HS50S

HTS58F

#### Compact Folding Leg Designs

The Classic Stands' flat base design of HS50S and HTS58F allows you to position the tripod base much lower than on standard stands. This means you can place this stand much closer to the bass drum or between other tripod stands in your setup.

HS50S snare stand features standard single braced tripod legs which allow you to adjust their extension for easy placement without getting in the way of the hi-hat and drum pedal.

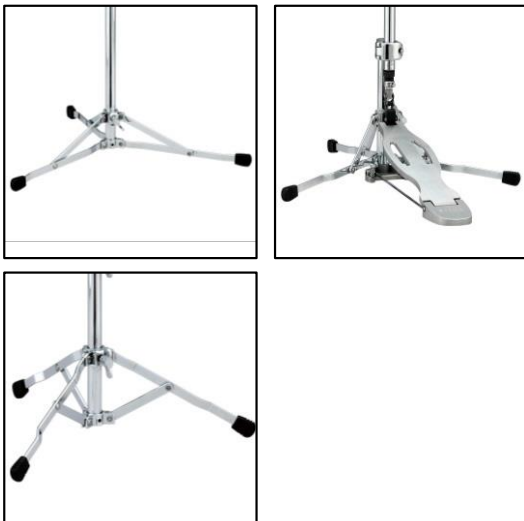

#### Die-Cast Pipe Joint / Memory Lock

The new Die-Cast Joint design provides a secure attachment by tightly gripping the tube with a metal plate that is held in place by the T-bolt. In addition, a memory lock prevents the pipe from any unwanted rotation or sliding.





# THE CLASSIC STAND SERIES

## HI-HAT STAND W/ SINGLE BRACED FLAT LEGS

Inspired by the vintage cymbal stands of the 1960s, we are proud to announce our new extremely lightweight and compact Classic Stands. These stands are not merely a rehash of old designs, but a beautiful blend of vintage style with the strength, adjustability, and reliability of modern construction. In addition, the hi-hat stand's compact folding design and light weight make it very easy to transport.



HH55F

### FEATURES



#### Knurled Base Section

To prevent one of the most common problems with flat base hi-hat stands – slippage of the tripod base/legs while playing – part of this stand's base pipe has a knurled surface to maximize the friction between the base pipe and T-bolt. It solved the issue effectively without sacrificing any usability or durability.(PAT. PENDING)

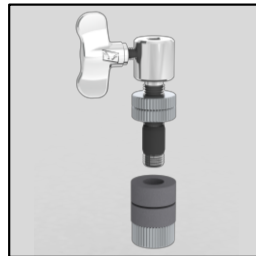

#### Hi-Hat Clutch

The clutch comes equipped with a protective nylon sleeve, saving your hi-hat cymbal from unwanted damage to the center hole.



#### Smooth Surface Classic Style Footboard

The newly designed classic style footboard takes advantage of both a lightweight construction and smooth surface, making it a great choice for any drumming style.

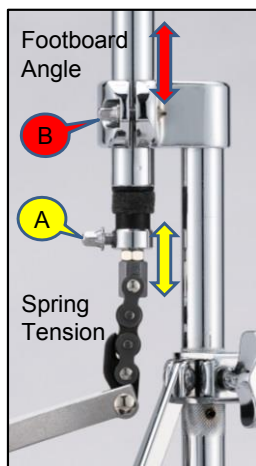

#### Individual Spring Tension & Footboard Angle Adjustment

The spring tension and footboard angle can be adjusted individually using a drum key.

##### Spring Tension Adjustment

While loosening the square head bolt (A), move the footboard up and down to adjust the spring tension.

##### Footboard Angle Adjustment

While loosening the square head bolt (B), slide the center pipe up and down to adjust the footboard angle.

### SPECIFICATIONS

- Adjustable Height Range: 950mm-650mm
- Size When Folded: Upper Section 500mm  
Base Section 598mm
- Weight: 2.3kg

### PRODUCT INFO.

Model #	Description	EAN Code	Availability	PRICE
HH55F	Hi-Hat Stand	4549763043597	Beginning of February	2.620,00 Kc 99,00 €

# THE CLASSIC STAND SERIES

## SNARE STAND W/ SINGLE BRACED LEGS

Inspired by the vintage cymbal stands of the 1960s, we are proud to announce our new extremely lightweight and compact Classic Stands. These stands are not merely a rehash of old designs, but a beautiful blend of vintage style with the strength, adjustability, and reliability of modern construction.

In addition, the single braced adjustable tripod makes for easy placement without getting in the way of the hi-hat and drum pedal.



HS50S

### FEATURES

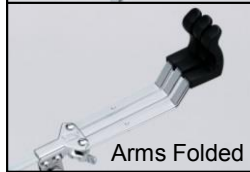
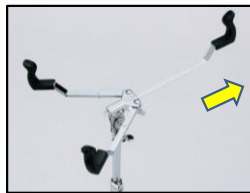

Arms Folded



#### Classic Style Basket

By simply loosening the T-nut, the length of one of the basket's arms can be adjusted to securely hold a 12" to 15" diameter snare drum. In addition, the other two arms can be folded for easy and compact transport.

#### Double Braced Arms

The two double braced basket arms eliminate any wobbling without overly restricting the drum's resonance or sustain.

#### Gearless Tilter

The Gearless Tilter securely holds its position using metal to metal contact, as opposed to traditional gears, allowing adjustments to any desired angle.

### SPECIFICATIONS

- 19.1mm Diameter Base Section Tubing
- Adjustable Height Range: 580mm-390mm
- Size When Folded: 600mm
- Weight: 1.7kg

### PRODUCT INFO.

Model #	Description	EAN Code	Availability	PRICE
HS50S	Snare Drum Stand	4549763043603	Beginning of February	1.700,00 Kc 64,00 €

# THE CLASSIC STAND SERIES

## TOM STAND W/ SINGLE BRACED FLAT LEGS

We proudly release extremely light and compact stands inspired by vintage cymbal stands of the 60's. But it is not only a rehash of vintage stands. It features many practical ideas which provide stability, adjustability and setting ability to drummers which our modern expertise can realize. And also, its flat base design allows you to position the tripod base much lower than on standard stands. This means you can place this stand much closer to the bass drum or between other tripod stands in your setup.



HTS58F

### FEATURES

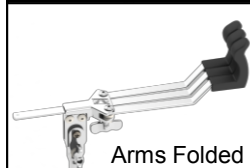
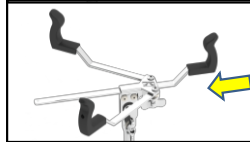
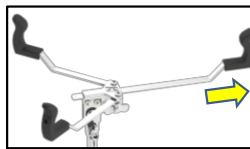

Arms Folded

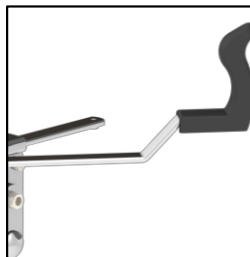

#### Classic Style Basket

By simply loosening the T-nut, the length of one arm can be adjusted to securely hold a 10" to 14" diameter tom. In addition, the other two arms can be folded for easy and compact transport.

#### Single Braced Arm

The single braced basket arms allow for the tom to resonate naturally and unhindered.

#### Gearless Tilter

The Gearless Tilter securely holds its position using metal to metal contact, as opposed to traditional gears, allowing adjustments to any desired angle.

### SPECIFICATIONS

- 19.1mm Diameter Base Section Tubing
- Adjustable Height Range: 820mm-565mm
- Size When Folded: Upper Section 598mm  
Base Section 407mm
- Weight: 1.8kg

### PRODUCT INFO.

Model #	Description	EAN Code	Availability	PRICE
HTS58F	Single Tom Stand	4549763043610	Beginning of February	1.830,00 Kc 69,00 €



# THE CLASSIC STAND SERIES

## HARDWARE KIT OF LIGHTWEIGHT CLASSIC STANDS

The hardware kit includes our new Classic Stand series, which feature vintage designs with modern construction and reliability. In addition to being very lightweight and compact, these stands have many practical features that make for easy setup and use.

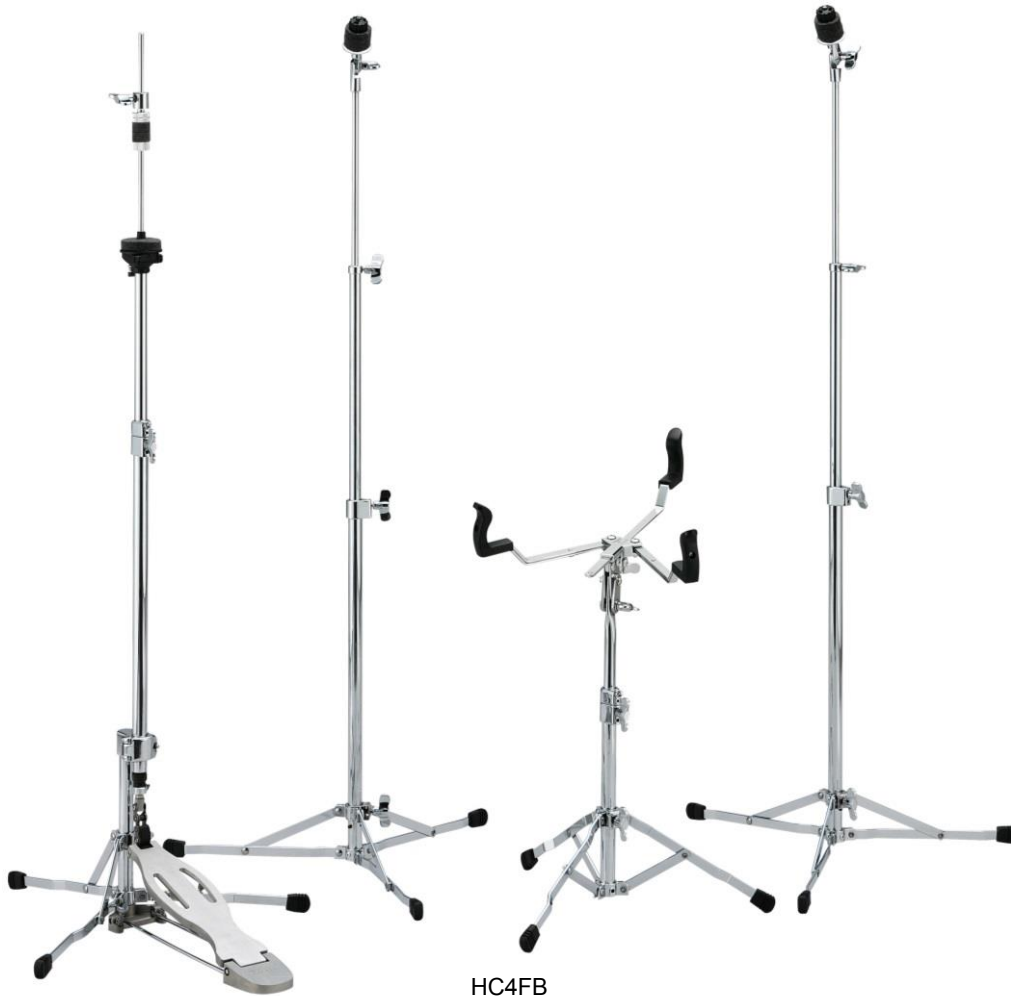

HC4FB

### SPECIFICATIONS

- HC52F Cymbal Stand x 2
- HH55F Hi-Hat Stand
- HS50S Snare Stand
- SBH01 Carrying Bag  
(670mm x 180mm x 190mm)
- Weight: 8.0kg

The hardware kit comes standard with a SBH01 hardware bag for easy transport. (SBH01 bag is also available as a single item)



### PRODUCT INFO.

Model #	Description	EAN Code	Availability	PRICE
HC4FB	4pc Hardware Kit w/Carrying Bag	4549763064752	Middle of April	7.390,00 Kc 279,00 €

# HOOP GRIP

## EXPAND YOUR DRUM SOUND

The Hoop Grip is a simple tool that allows you to add cymbals or other accessories to your drum kit to expand your setup and customize your sound with ease. The possibilities are endless!

### FEATURES



MC8

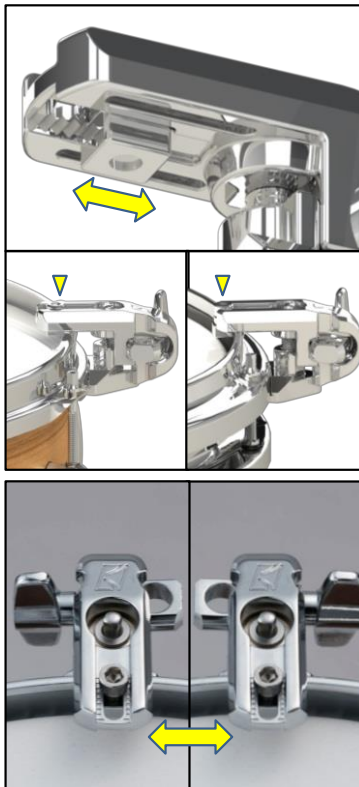

#### Adjustable Claw

You can mount this Hoop Grip on various shaped hoops by adjusting the position of the claw on the upper side – simply loosen the hexagon socket head bolt and slide the claw to adjust.

#### Dual Position Rod Holder

You can choose from two positions for the cymbal/accessory mounting rod, depending on your setup preference. This allows for greater flexibility and options.

### ACCESSORY MOUNT ARM & Z-RODS

#### Z-Rod for Cowbell



ZCB

#### Z-Rod for Splash Cymbal



ZCYE

ZCYEL  
(Long)

#### Accessory Mount Arm



HCA20

# HOOP GRIP

## EXPAND YOUR DRUM SOUND

### USAGE EXAMPLES

- For More Flexible Accessory/Cymbal Setup



**MC8 + ZCB + Cowbell**



**MC8 + ZCYE + Splash Cymbal**



- For Customizing the Drum Sound



**MC8 + HCA20  
+ TJR7 Jingle Ring**



**MC8 + HCA20  
+ Splash Cymbal**



**MC8 + HCA20+ BSQ10S  
Soft Sound Beater**

### PRODUCT INFO.

Model #	Description	EAN Code	Availability	PRICE
<b>MC8</b>	Hoop Grip	4549763068071	Middle of April	660,00 Kc / 24,90 €
<b>HCA20</b>	Accessory Mount Arm	4549763068118	Middle of April	530,00 Kc / 19,90 €
<b>ZCB</b>	Z-Rod for Cowbell	4549763068101	Middle of April	340,00 Kc / 12,90 €
<b>ZCYE</b>	Z-Rod for Splash Cymbal	4549763068088	Middle of April	470,00 Kc / 17,90 €
<b>ZCYEL</b>	Z-Rod for Splash Cymbal (Long)	4549763068095	Middle of April	500,00 Kc / 18,90 €



# TENSION LOCK

## KEEPS DRUM HEAD TENSION WHILE PLAYING

The Tension Lock is an accessory to prevent tension bolts from loosening while playing. Simply set it on the tension bolt head – its unique shape fits perfectly. On the other hand, you can tune the drum without having to detach the Tension Lock, thanks to an elastic O-ring around its hole. It is a small accessory, but filled with TAMA's unique ideas.



### FEATURES

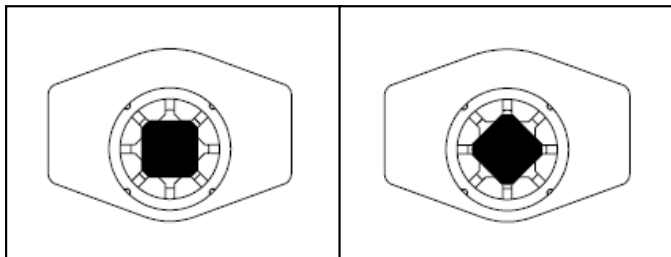

#### Perfect Fit Octagonal Hole

With eight evenly placed bumpers around the hole, the Tension Lock fits perfectly on a square head bolt. This prevents the bolt from loosening.

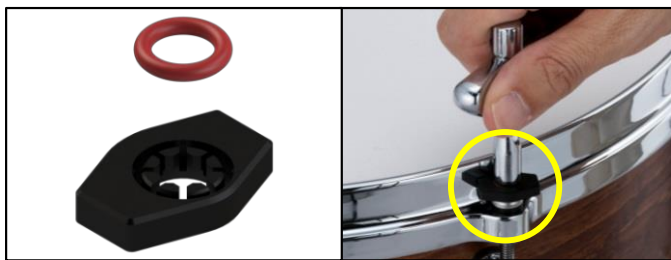

#### Elastic-Flex O-ring

The O-ring built into the Tension Lock is flexible, allowing for the Tension Lock to accommodate the different shapes/sizes of tension rod heads between different manufacturers. Because of the O-ring's elasticity, you can tune the drum with the Tension Lock in place without deforming the bumpers' original shape, even after extended use.



#### Fits Most Drum Hoops

The offset position of the hole allows the Tension Lock to fit a wide range of hoops.

\*Can be fit for all TAMA drum hoops, except Wood Hoops and Grooved Hoops.

### PRODUCT INFO.

Model #	Description	EAN Code	Availability	PRICE
TTL10	Tension Lock (10pcs / pack)	4549763068125	Middle of March	260,00 Kc / 9,90 €

# STANDARD DRUM BAG SET

## FOR CLUB-JAM DRUM KIT

The TAMA Standard Drum Bag Set features bags with 10mm of inner cushion and 600 denier waterproof surfaces, which securely protect your drums during transport. The bags are also equipped with a comfortable carrying strap for easy portability. There are various pre-configured sets available, to cater to different setups. While the bags do feature our iconic red zipper and simple "T" logo, they work great for any other drum brands' products as well.



DSS48LJ

### FEATURES

- 600 denier high density water resister surface
- Water resistant nylon with 10mm thick cushion
- Ergonomic rubber handles
- Carrying strap with shoulder pads (except bass drum bag)

### **PRODUCT INFO.**

Model #	Description	EAN Code	Availability	PRICE
DSS48LJ	Standard Drum Bag Set 12"x18" BD, 7"x14" FT & 5"x13" SD (1 bag), 8"x10" TT	4549763062376	On Stock	2.620,00 Kc 99,00 €

# STANDARD DRUM BAG SET

## FOR STANDARD 18" BASS DRUM KIT

The TAMA Standard Drum Bag Set features bags with 10mm of inner cushion and 600 denier waterproof surfaces, which securely protect your drums during transport. The bags are also equipped with a comfortable carrying strap for easy portability. There are various pre-configured sets available, to cater to different setups. While the bags do feature our iconic red zipper and simple "T" logo, they work great for any other drum brands' products as well.



DSS48S

### FEATURES

- 600 denier high density water resister surface
- Water resistant nylon with 10mm thick cushion
- Ergonomic rubber handles
- Carrying strap with shoulder pads (except bass drum bag)
- Tom bags accommodate drums with Star-Cast mounts

### PRODUCT INFO.

Model #	Description	EAN Code	Availability	PRICE
DSS48S	Standard Drum Bag Set 14"x18" BD, 9"x12" TT, 14"x14" FT, 6.5"x14" SD	4549763062352	On Stock	3.950,00 Kc 149,00 €



# STANDARD DRUM BAG SET

## FOR 7PC DRUM KIT

The TAMA Standard Drum Bag Set features bags with 10mm of inner cushion and 600 denier waterproof surfaces, which securely protect your drums during transport. The bags are also equipped with a comfortable carrying strap for easy portability. There are various pre-configured sets available, to cater to different setups. While the bags do feature our iconic red zipper and simple "T" logo, they work great for any other drum brands' products as well.



DSS72S

### FEATURES

- 600 denier high density water resister surface
- Water resistant nylon with 10mm thick cushion
- Ergonomic rubber handles
- Carrying strap with shoulder pads (except bass drum bag)
- Tom bags accommodate drums with Star-Cast mounts

### PRODUCT INFO.

Model #	Description	EAN Code	Availability	PRICE
DSS72S	Standard Drum Bag Set 18"x22" BD, 7"x8" TT, 8"x10" TT, 9"x12" TT, 14"x14" FT, 16"x16" FT, 6.5"x14" SD	4549763062369	On Stock	5.800,00 Kc 219,00 €

# NEW STANDARD HARDWARE BAG

## FOR COMPACT & LIGHTWEIGHT HARDWARE

This bag is very suitable for carrying compact and lightweight hardware such as the flat base type stands. While being lightweight and easy to handle, it also has enough cushioning to protect the equipment from external damage while in transit. It comes equipped with a handle and strap for easy portability. The simple design with the red zipper in standard black color make it an attractive match with any brands hardware.

**SBH01**

### FEATURES

- Lightweight and easy to handle size
- Equipped with a handle and strap
- Simple and eye-catching design with red zipper and iconic "T" logo
- Size: 670(L) x 180(W) x 190(H) mm

\* This bag is included in HC4FB hardware kit.



Suitable for TAMA Classic Stands,  
and any Compact / Lightweight Hardware

### PRODUCT INFO.

Model #	Description	EAN Code	Availability	PRICE
SBH01	Hardware Bag	4549763066923	End of March	870,00 Kc 33,00 €

# STEEL MINI-TYMP

## NEW SET OF 4"X10" + 4"x12"

TAMA's Steel Mini-Tymp are ideal for adding new sonic color to your kit. They produce a clear, sharp, percussive "crack" that give drummers a new way to add accent to their playing, no matter what style of music. Come with an L-rod (LLT) and a multi-clamp (MC66) for fast, easy mounting.



MT1012ST

### PRODUCT INFO.

Model #	Description	EAN	Availability	PRICE
MT1012ST	Steel Mini-Tymp 10" + 12"	4549763062215	Middle of February	5.010,00 Kc 189,00 €



# OAK LAB SERIES DRUM STICKS

## NEW POSSIBILITIES OF OAK STICKS

The Oak Lab series is an ambitious series trying to expand the new possibilities of sticks by focusing on the unique potential of the Oak material. While most of Oak sticks in the world ever have utilized the shape developed for Hickory sticks, we have thoroughly analyzed its balance of hardness and weight; which usually leaves the reputation that Oak is hard to control, but has the advantage of high durability. By pursuing original shapes and balance that utilize the hardness and weight we realized high levels of controllability that improve playability without changing the Oak's feature of high durability. Furthermore, our Oak Lab Series sticks draw the cymbal's rich mid-low tone which cannot be obtained by Hickory or Maple. In addition, you can select the right sticks to improve your playing style, our range of sticks cater towards specific directions such as speed, delicate control, power and so on.

Whether or not you are a drummer that has used Oak until now, drummers of all persuasions and playing styles will highly appreciate the Oak Lab Series Sticks.

Oak Lab  
Smash



OL-SM

Oak Lab  
Resonator



OL-RE

Oak Lab  
Fast Blast



OL-FA

Oak Lab  
Swingin'



OL-SW

Oak Lab  
Full Balance



OL-FU

## SMASH



The Smash is designed for the drummer who needs a powerful sound and punchy attack.

In order to make it easier to achieve the perfect smash, we specially designed this stick to bring the center of gravity forward. It adopts 419 mm longer entire length, a larger tip and a shorter shoulder area. This realigned center of gravity balance produces a strong centrifugal force and realizes a powerful sound. By using huge acorn shaped tip hits, the drum head over a large area is capable of delivering a louder volume.

### FEATURES

- Length: 419 mm (16 1/2"), Diameter: 15 mm (.590")
- Designed for a powerful sound and punchy attack
- Centrifugal force generated powerful sound caused by bringing the center of gravity forward.
- Huge acorn tip, hits the drum head over a large area is capable of delivering a louder volume
- Made of Japanese Oak

## RESONATOR



The Resonator model is adjusted to bring out a rich resonance from the drum itself.

Because the weight of this stick itself is heavy due to its larger size and its Oak material, drummers are able to easily achieve a louder volume enough, even if you don't hit so hard. On the other hand, since the center of gravity is set to be closer to the grip end side, it is easy to handle without feeling such weight in hand. These sticks most notably demonstrate their true value in medium slow and slow tempo songs.

### FEATURES

- Length: 410 mm (16 5/32 ") Diameter: 15.25 mm (0.600 ")
- Adjusted to bring out a rich resonance of drum itself.
- Easy to handle without feeling the weight in hand.
- Sharpened tip that provides rich, full-volume sound and various sound character.
- Made of Japanese Oak

## FAST BLAST



The Fast Blast is the best choice for drummers seeking volume as well as speed.

Although it is a slim stick suitable for fast playing, it is also able to easily obtain volume due to the weight of Oak material itself. The tip has been adjusted to a larger size for ball tip, which offers easy handling and a large volume. Instead of lacquer finish, we adopt rough grinded finish with a sand paper. It gives a natural and comfort grip, and prevents slipping during faster playing.

### FEATURES

- Length: 406 mm (16"), Diameter: 14 mm (0.550")
- Best choice for drummers seeking volume as well as speed
- Large size ball tip that is suitable to easy handling and large volume
- A rough grinded finish without lacquer finish prevents slipping.
- Made of Japanese Oak

## SWINGIN'



This Swingin' model is very suitable to a genres requiring detailed control of the timbre and dynamics, such as jazz music. Typically, small diameter sticks are more difficult to control. However, this model's weight balance of Oak material resolves this difficulty and makes it easy to handle from intricate delicate playing to louder dynamic playing. The hardness of Oak tips draws a unique cymbal sound that is bright, clear, yet different from the nylon tip. By adopting a small size oval shape oak tip, this model delivers a clear sound even during detailed delicate playing.

### FEATURES

- Length: 403 mm (15 7/8"), Diameter: 12.75 mm (0.500")
- Very suitable to a scene where required to seriously control the timbre and dynamics.
- Small oval Oak tip that brings a bright, clear cymbal sound and delicate stick control
- Made of Japanese Oak

## FULL BALANCE



This Full Balance is an attractive model for its all round versatility. As far as size, this model is the standard 406mm (16") length, 14.5mm (0.570") diameter, Oak materials makes it slightly heavier to increase the accuracy of the stick control. The True Round shape tip allow players to easily arrange the balance of tones and volume because it hits the drum head and cymbal in the same dimension even when hitting changes. Additionally, the combination of True Round tip shape and hardness of Oak material provide a well-balanced timbre and clear attack.

### FEATURES

- Length: 406 mm (16"), Diameter: 14.5 mm (0.570")
- All round versatility for any music style
- Slightly heavier to increase the accuracy of the stick control.
- True Round tip makes it easy to arrange the balance of tones and volume.
- Made of Japanese Oak

## PRODUCT INFO.

Model #	Description	EAN Code	Availability	PRICE
OL-SM	Oak Drum Stick "Smash"	4549763062314	Middle of February	260,00 Kc / 9,90 €
OL-RE	Oak Drum Stick "Resonator"	4549763062307	Middle of February	260,00 Kc / 9,90 €
OL-FA	Oak Drum Stick "Fast Blast"	4549763062284	Middle of February	260,00 Kc / 9,90 €
OL-SW	Oak Drum Stick "Swingin'"	4549763062321	Middle of February	260,00 Kc / 9,90 €
OL-FU	Oak Drum Stick "Full Balance"	4549763062291	Middle of February	260,00 Kc / 9,90 €



# REFINED PACKAGE DESIGN OF TAMA ACCESSORIES

## SNARE DRUM HOOPS

Popular TAMA snare drum hoops featuring updated package with new POP sticker. The prices are adjusted to be more competitive.



Model#	Description	EAN	PRICE
<b>Die-Cast Hoop</b>			
MDH14-8	14" 8 hole batter side	4515276110491	1.300,00 Kc 49,00 €
MDH14S-8	14" 8 hole snare side	4515276110521	1.300,00 Kc 49,00 €
MDH14-10	14" 10 hole batter side	4515276110477	1.300,00 Kc 49,00 €
MDH14S-10	14" 10 hole snare side	4515276110514	1.300,00 Kc 49,00 €
<b>2.3mm Steel Mighty Hoop</b>			
MFM14-8	14" 8 hole batter side	4515276110996	770,00 Kc 29,00 €
MFM14S-8	14" 8 hole snare side	4515276111030	770,00 Kc 29,00 €
MFM14-10	14" 10 hole batter side	4515276110989	770,00 Kc 29,00 €
MFM14S-10	14" 10 hole snare side	4515276111023	770,00 Kc 29,00 €
<b>2.3mm Sound Arc Hoop</b>			
MSH1410	14" 10 hole batter side	4515110818224	930,00 Kc 35,00 €
MSH14S10	14" 10 hole snare side	4515110818231	980,00 Kc 37,00 €
<b>2.3mm Brass Mighty Hoop</b>			
MFB14-10N	14" 10 hole batter side	4515276110651	1.830,00 Kc 69,00 €
MFB14S-10N	14" 10 hole snare side	4515276110675	1.830,00 Kc 69,00 €
<b>2.3mm Brass Sound Arc Hoop</b>			
MSB148D	14" 8 hole batter side	4515276892502	1.830,00 Kc 69,00 €
MSB14S8D	14" 8 hole snare side	4515276892519	1.830,00 Kc 69,00 €
<b>Maple Wood Hoop</b>			
WMH1408B	14" 8 hole batter side	4515276628385	2.090,00 Kc 79,00 €
<b>NEW</b> WMH1408S	14" 8 hole snare side	4515276628392	2.090,00 Kc 79,00 €
<b>NEW</b> WMH1410B	14" 10 hole batter side	4549763066527	2.090,00 Kc 79,00 €
<b>LTD</b> WMH1410S	14" 10 hole snare side	4549763066534	2.090,00 Kc 79,00 €

# REFINED PACKAGE DESIGN OF TAMA ACCESSORIES

## SNARE WIRES

Popular TAMA snare wires featuring updated package. Some selected items have new POP sticker on the package. All prices are adjusted to be more competitive.

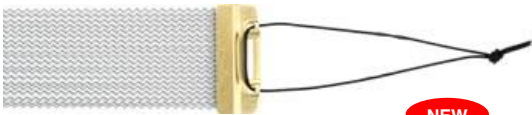

### Super Sensitive Hi-Carbon Snare Wire for Concert

A thin brass plate and softer hi-carbon coils respond to even the softest touch on the edge of the batter head.



### Stainless Steel Straight Wire

20 strands steel straight wire for concert.

Model#	Description	EAN	PRICE
--------	-------------	-----	-------

#### Super Sensitive Hi-Carbon Snare Wire

MS20RL13C	14" 20 strands Hi-Carbon steel	4515110639218	530,00 Kc 19,90 €
MS20RL14C*	14" 20 strands Hi-Carbon steel	4515110624580	530,00 Kc 19,90 €

#### Starclassic Snare Wire

MS20SN10S	10" 20 strands Carbon steel	4515276217848	340,00 Kc 12,90 €
MS20SN12S	12" 20 strands Carbon steel	4515276217855	340,00 Kc 12,90 €
MS20SN13C	13" 20 strands Hi-Carbon steel	4515110820210	530,00 Kc 19,90 €
MS20SN13S	13" 20 strands Carbon steel	4515276217862	340,00 Kc 12,90 €
MS20SN14B*	14" 20 strands Bell Brass	4515276217879	530,00 Kc 19,90 €
MS20SN14C*	14" 20 strands Hi-Carbon steel	4515276369745	530,00 Kc 19,90 €
MS20SN14S*	12" 20 strands Carbon steel	4515276217886	340,00 Kc 12,90 €

#### Regular Snare Wire

MS12R14S	14" 12 strands Carbon steel	4515276021117	260,00 Kc 9,90 €
MS20R14S*	14" 20 strands Carbon steel	4515276021124	290,00 Kc 10,90 €
MS30R14S*	14" 30 strands Carbon steel	4515276872092	470,00 Kc 17,90 €
MS42R14C*	14" 42 strands Hi-Carbon steel	4515276369752	550,00 Kc 20,90 €
MS42R14S*	14" 42 strands Carbon steel	4515276021858	500,00 Kc 18,90 €

#### Super Sensitive Hi-Carbon Snare Wire for Concert

MS20L14C8	14" 20 strands Hi-Carbon steel	4515276672432	530,00 Kc 19,90 €
-----------	--------------------------------	---------------	----------------------

#### NEW Stainless Steel Straight Wire

MS20M14ST	14" 20 strands steel	4515276902317	1.060,00 Kc 39,90 €
-----------	----------------------	---------------	------------------------

#### NEW Introductory Special Package

SNARE5PV1	Package of MS20R14S, MS20RL14C, MS20SN14S, MS30R14S, MS42R14S (2pcs each)	4549763066558	
-----------	---	---------------	--

LTD

\*POP Sticker attached

# S.L.P. SOUND LAB PROJECT

## 8" X 15" BIG BLACK STEEL

The "Big Black Steel" snare fills the role of the classic, big, deep rock snare drum – and then some. Its husky 8" deep Steel shell provides maximum power and volume, making it an ideal choice for players who need to cut through the crushing din of guitars.

This Limited Edition "Big Black Steel" goes even further by adding an inch in diameter, resulting in an 8" x 15" beast that is extra fat and powerful. This uniquely sized snare is sure to impress rock drummers looking to take things up a notch.



LST158

### FEATURES

- 8"x15" size for maximum power and volume
- All Black Nickel plating finish
- Suggested musical styles: Heavy Metal, Hard Rock & Alternative Rock

### PRODUCT INFO.

<b>Model #</b>	LST158
<b>Size</b>	8" x 15"
<b>Shell</b>	1mm Steel
<b>Lug</b>	MSL35BN Lug
<b>Hoop</b>	Steel Mighty Hoop (10 Hole)
<b>Head</b>	EVANS G1 Coated / Snare Side
<b>Strainer/Butt</b>	MCS70ABN / MCS70BBN
<b>Snare Wire</b>	MS20SN15S
<b>EAN Code</b>	4549763062345
<b>Availability</b>	Middle of February
<b>PRICE</b>	7.130,00 Kc / 269,00 €



# IRON COBRA 25TH ANNIVERSARY

## IRON COBRA 600 DRUM PEDAL JET BLACK SPECIAL EDITION

We are proud to offer our popular HP600D bass drum pedal in this limited edition, stunning jet black finish with red accents. The HP600D pedal is highly regarded by drummers around the world because it adopts so many features from our flagship Iron Cobra 900 series. In addition, this limited edition version features the 900's Power-Strike Cobra Beater, completing this pedal's very special combination of looks, sound, and function.



HP600DBK



Power-Strike Cobra Beater



Flashy Red Logo on Jet Black Finish

### FEATURES

- Limited Edition Jet Black Finish
- Power-Strike Cobra Beater's focused sound and improved control
- Duo Glide cam that can be switched between two different actions

### PRODUCT INFO.

Model #	Description	EAN Code	Availability	PRICE
HP600DBK	Single Drum Pedal	4549763059185	Middle of February	3.420,00 Kc 129,00 €

# 1ST CHAIR GLIDE RIDER

## FEATURING COLORED CLOTH TOP SEATS

What determines the first impression of a drum throne is the hardness of the seat. In the moment a drummer sits down on the throne, he/she understands whether it's a suitable fit or not. The final decision is very simple, but it depends on many complicated factors. After detailed investigations into shape, material, stretch of cloth, and method of sewing, we release the new Glide Rider drum throne—it's an ideal balance between softness and hardness we hadn't tried before this.

HT530DBCN features dark blue cloth top seat, and HT530DRCN features dark red cloth top seat.



HT530DBCN



HT530DRCN

### SPECIFICATIONS

- 1st Chair Height Adjustment
- Seat Lock
- Glide-Tite Grip Joint
- Rocklok
- Oversized Rubber Feet
- Foot Life
- Height Adjustment Range: 485mm – 640mm (19" -25 3/16")

### PRODUCT INFO.

Model #	Description	EAN Code	Availability	PRICE
HT530DBCN	Drum Throne w/ Dark Blue Cloth Top Seat	4549763043504	On Stock	5.270,00 Kc 199,00 €
HT530DRCN	Drum Throne w/ Dark Red Cloth Top Seat	4549763043511	On Stock	5.270,00 Kc 199,00 €